

# **LONG-RANGE SURVEILLANCE UNIT OPERATIONS**

HEADQUARTERS,  
DEPARTMENT OF THE ARMY

DISTRIBUTION RESTRICTION: Approved for public release; distribution is unlimited.

**LONG-RANGE SURVEILLANCE  
UNIT OPERATIONS**

**CONTENTS**

	Page
PREFACE . . . . .	v
<b>CHAPTER 1. INTRODUCTION</b>	
<b>Section I. Objective . . . . .</b>	<b>1-1</b>
1-1. Information Gathering . . . . .	1-1
1-2. Human Intelligence Capabilities . . . . .	1-1
1-3. Army Operations Doctrine . . . . .	1-3
<b>Section II. Mission . . . . .</b>	<b>1-4</b>
1-4. Characteristics . . . . .	1-4
1-5. Mission Execution . . . . .	1-5
<b>Section III. Organization . . . . .</b>	<b>1-6</b>
1-6. Long-Range Surveillance Company . . . . .	1-6
1-7. Long-Range Surveillance Detachment . . . . .	1-8
1-8. Capabilities . . . . .	1-9
1-9. Limitations . . . . .	1-9
1-10. Weapons and Equipment . . . . .	1-10
<b>CHAPTER 2. FUNDAMENTALS</b>	
<b>Section I. Command and Control . . . . .</b>	<b>2-1</b>
2-1. Structure . . . . .	2-1
2-2. Mission Taskings . . . . .	2-2
2-3. Types of Missions . . . . .	2-4
2-4. Leadership . . . . .	2-5
2-5. Surveillance Team Operations . . . . .	2-9
2-6. Operations Base . . . . .	2-11
2-7. Tactical Operations Center . . . . .	2-14
2-8. Task Organization . . . . .	2-19

DISTRIBUTION RESTRICTION—Approved for public release; distribution is unlimited.

\*This publication supersedes FM 7-93, 9 June 1987.

	Page
<b>Section II. Communications</b> . . . . .	<b>2-19</b>
2-9. Communication Nets . . . . .	2-20
2-10. Messages and Reports . . . . .	2-22
2-11. Base Radio Station Operations . . . . .	2-25
2-12. Surveillance Team Communications . . . . .	2-26
2-13. Electronic Warfare . . . . .	2-27
<b>Section III. Mission Development</b> . . . . .	<b>2-29</b>
2-14. Planning . . . . .	2-29
2-15. Coordination . . . . .	2-33
2-16. Warning Order . . . . .	2-33
<b>Section IV. Operational Security</b> . . . . .	<b>2-34</b>
2-17. Tactical and Administrative Measures . . . . .	2-34
2-18. Electronic Measures . . . . .	2-35
 <b>CHAPTER 3. OPERATIONS</b>	
<b>Section I. Planning Phase</b> . . . . .	<b>3-1</b>
3-1. Contingency Plans . . . . .	3-1
3-2. Control Measures . . . . .	3-2
3-3. Planning Area Activities . . . . .	3-2
<b>Section II. Infiltration Phase</b> . . . . .	<b>3-6</b>
3-4. Movement to the Departure Area . . . . .	3-6
3-5. Stay-Behind . . . . .	3-6
3-6. Infiltration . . . . .	3-6
3-7. Air Insertion . . . . .	3-8
3-8. Amphibious Infiltration . . . . .	3-11
3-9. Land Infiltration . . . . .	3-14
<b>Section III. Execution Phase</b> . . . . .	<b>3-16</b>
3-10. Movement to the Area of Operations . . . . .	3-16
3-11. Hide Site and Surveillance Site Occupation . . . . .	3-17
3-12. Site Selection . . . . .	3-18
3-13. Actions in the Area of Operations . . . . .	3-18
3-14. Reports . . . . .	3-20
3-15. Movement to the Extraction Site . . . . .	3-20
<b>Section IV. Exfiltration Phase</b> . . . . .	<b>3-21</b>
3-16. Distances . . . . .	3-21
3-17. Terrain . . . . .	3-21
3-18. Enemy . . . . .	3-22
3-19. Evasion and Escape . . . . .	3-22
3-20. Extraction by Air . . . . .	3-23
3-21. Land Exfiltration . . . . .	3-23
<b>Section V. Recovery Phase</b> . . . . .	<b>3-24</b>
3-22. Debriefing . . . . .	3-24
3-23. Equipment Maintenance and Turn-In . . . . .	3-24
3-24. Stand-Down . . . . .	3-24
3-25. Training . . . . .	3-25

	Page
<b>CHAPTER 4. SUPPORT</b>	
<b>Section I. Combat Support</b> . . . . .	<b>4-1</b>
4-1. Joint Service Support . . . . .	4-1
4-2. Army Aviation Support . . . . .	4-3
4-3. Fire Support . . . . .	4-3
4-4. Air Defense Artillery Support . . . . .	4-5
4-5. Engineer Support . . . . .	4-5
4-6. Electronic Warfare Support . . . . .	4-5
<b>Section II. Combat Service Support</b> . . . . .	<b>4-5</b>
4-7. Sources . . . . .	4-6
4-8. Supply . . . . .	4-6
4-9. Resupply . . . . .	4-6
4-10. Transportation . . . . .	4-8
4-11. Maintenance . . . . .	4-8
4-12. Medical . . . . .	4-8
4-13. Miscellaneous Services . . . . .	4-9
<b>CHAPTER 5. LRS IN OPERATIONS OTHER THAN WAR</b>	
5-1. Activities . . . . .	5-1
5-2. Planning Factors for Operations Other Than War . . . . .	5-1
5-3. LRS Missions in Operations Other Than War . . . . .	5-3
<b>CHAPTER 6. INFILTRATION AND EXFILTRATION</b>	
<b>Section I. Waterborne Operations</b> . . . . .	<b>6-1</b>
6-1. Planning Considerations . . . . .	6-1
6-2. F470 Zodiac Boat . . . . .	6-2
6-3. Scout Swimmer . . . . .	6-9
6-4. Helocasting Operations . . . . .	6-11
<b>Section II. Helicopter Operations</b> . . . . .	<b>6-13</b>
6-5. Rappelling . . . . .	6-13
6-6. Special Patrol Infiltration/Exfiltration System . . . . .	6-14
6-7. Fast-Rope Infiltration/Exfiltration System . . . . .	6-24
6-8. Army Aviation and Air Assault . . . . .	6-28
<b>Section III. Airborne Operations</b> . . . . .	<b>6-36</b>
6-9. Landing Plan . . . . .	6-37
6-10. Air Movement Plan . . . . .	6-37
6-11. Marshalling Plan . . . . .	6-37
<b>Section IV. Stay-Behind Operations</b> . . . . .	<b>6-37</b>
6-12. Planning . . . . .	6-38
6-13. Site Preparation . . . . .	6-38
<b>Section V. Vehicle Operations</b> . . . . .	<b>6-38</b>
6-14. Planning . . . . .	6-38
6-15. LRS Team Planning . . . . .	6-38
<b>Section VI. Foot Movement Operations</b> . . . . .	<b>6-39</b>
6-16. Planning . . . . .	6-39
6-17. Movement . . . . .	6-39

APPENDIX A. **PERSONNEL RECRUITMENT AND SELECTION . . . . . A-1**

APPENDIX B. **LONG-RANGE SURVEILLANCE RECONNAISSANCE . . . . . B-1**

APPENDIX C. **GEOGRAPHIC ENVIRONMENTS . . . . . C-1**

APPENDIX D. **COMMUNICATIONS . . . . . D-1**

APPENDIX E. **LRSU HIDE AND SUVEILLANCE SITES . . . . . E-1**

APPENDIX F. **TRACKING AND COUNTERTRACKING, EVASION  
AND ESCAPE, AND SURVIVAL . . . . . F-1**

APPENDIX G. **INTELLIGENCE . . . . . G-1**

APPENDIX H. **ORDERS . . . . . H-1**

APPENDIX I. **BRIEFBACK AND DEBRIEFING FORMATS . . . . . I-1**

APPENDIX J. **MOVEMENT TECHNIQUES AND BATTLE DRILLS . . . . . J-1**

APPENDIX K. **NIGHT OPERATIONS . . . . . K-1**

GLOSSARY . . . . . **Glossary-1**

REFERENCES . . . . . **References-1**

INDEX . . . . . **Index-1**

## PREFACE

This manual provides doctrine, tactics, techniques, and procedures on how long-range surveillance units perform combat operations. Long-range surveillance units include long-range surveillance companies at corps, and long-range surveillance detachments in mechanized, infantry, airborne, air assault, and light infantry divisions. This manual is aligned with Army operations doctrine (FM 100-5). It is not a stand-alone publication. A knowledge of FM 7-8 is essential.

The primary audiences for this manual are corps and division commanders, corps and division G3s and G2s, military intelligence battalion commanders that have subordinate long-range surveillance units, long-range surveillance company and detachment commanders, platoon leaders, platoon sergeants, and team leaders. Secondary audiences include other infantry, armor, field artillery, and aviation leaders and staff officers, special operations forces leaders and staff officers, and service schools.

LRSU leaders should use this manual in developing methodologies for training, planning, coordinating, and executing LRS missions. By adhering to doctrinally sound methodologies, leaders significantly increase the unit's chance for mission success.

Tough, realistic training is the key to successful execution. The specifics of how to train the LRS company, detachment, and team are in ARTEP 7-93-MTP. ARTEP 7-8-MTP should also be used as a supplement in training LRS teams. These ARTEPs provide the tasks, conditions, and standards for training, and outline how to integrate individual, leader, and soldier tasks.

The proponent for this publication is the United States Army Infantry School. Send comments and recommendations on DA Form 2028 directly to: Commandant, US Army Infantry School, ATTN: ATSH-RB, Fort Benning, Ga 31905-5430.

Unless otherwise stated, whenever the masculine gender is used, both men and women are included.

## CHAPTER 1

### INTRODUCTION

*Combat forces need accurate and timely intelligence about enemy forces, terrain, and weather. Commanders must make fast and accurate decisions to have the right combat force at the right place and time. Their decisions are partly based on information gathered for intelligence purposes. Long-range surveillance units are trained and equipped to gather this information.*

#### Section I. OBJECTIVE

Human intelligence is a category of intelligence derived from information collected and provided by human sources (JCS Pub 1-02). Human intelligence has always been a primary source of information within the intelligence collection system. Frontline soldiers and reconnaissance patrols have always provided combat information to tactical commanders. Commanders at all levels need this type of information. The long-range surveillance teams are a primary source of human intelligence.

#### 1-1. INFORMATION GATHERING

Information is collected from every source and disseminated immediately as combat information, or it is first processed into intelligence. Collection of information is one phase of the intelligence cycle. The cycle consists of direction, collection, processing, and dissemination. These phases may be conducted both sequentially and concurrently. While information is being processed, additional information is being collected. At the same time, the intelligence staffs plan and direct the collection effort to meet new requirements. Data gained from the intelligence cycle, coupled with existing data, enable intelligence staffs to predict battlefield events and enemy intentions. By comparing time with actual events, the G2 can provide the commander timely, complete, and accurate intelligence.

#### 1-2. HUMAN INTELLIGENCE CAPABILITIES

Long-range surveillance units provide the corps with a dedicated company and the division with a dedicated detachment. These units are specially trained and equipped to collect human intelligence about forces deep in the enemy's rear. LRS units are part of the overall intelligence collection process. They augment and complement other collection systems that are more vulnerable to limitations such as weather, range, terrain masking, and enemy countermeasures. LRS units also allow corps and division

commanders to gather timely information that does not need lengthy processing and analysis.

a. The employment ranges for the LRSU missions depend on METT-T, operational tempo, and support considerations. In a fast-paced battlefield environment, the depth of LRSU employment is greater because the area of interest is larger. Long-range surveillance detachment teams operate forward of battalion reconnaissance teams and cavalry scouts in the division area of interest. The long-range surveillance company teams operate forward of the LRSD teams and behind most special operations forces. (See Table 1-1.) The duration of an LRS mission depends on equipment and supplies the team must carry, movement distance to the objective area, and resupply availability. LRSU teams normally operate up to seven days without resupply depending on terrain and weather. Teams may be deployed longer in special cases. Operations other than war are likely to be nonlinear, with no identifiable forward line of own troops. Surveillance must extend in all directions. Deployment considerations are adjusted with the political and geographical effects included. The specific area of operations changes as additional maneuver units are sent into the area of operations.

b. LRS teams are organized, trained, and equipped to enter enemy areas to observe and report enemy dispositions, movements and activities, and battlefield conditions. The teams' missions, targets, and objectives are based on the intelligence requirements of the commander. Teams infiltrate selected areas by air, ground, water, or stay-behind. While avoiding contact with the enemy and local civilians, these teams observe. They may emplace a variety of unattended sensors and special-purpose equipment to detect, observe, and monitor enemy activities. They perform other specified collection tasks as well. **LRS teams are not intended, and lack the capability, to conduct direct-action missions.** Their mission of limited reconnaissance and stationary surveillance is different from the missions of most special forces and rangers.

c. Teams operating in the corps or division area of interest use highly developed infantry and ranger skills to infiltrate enemy-controlled areas, evade enemy rear-security operations, then exfiltrate with or without assistance. These infantry and ranger skills are needed for survival and to complete the mission. Teams also have expert information-collection skills, and they know enemy organizations, tactics, and equipment. They are also experts in using communication systems. These skills are attained through individual, institutional, and unit (collective) training programs. (See Appendix A for information on personnel recruitment and selection.)



LEVEL	ELEMENT	LOCATION
STRATEGIC LEVEL Special Reconnaissance Combat Operations	Special Forces Ranger/Special Forces	THEATER
OPERATION LEVEL Surveillance  Reconnaissance  Combat Operations	Long-Range Surveillance Company  Long-Range Surveillance Company Rangers/Corps Troops	CORPS
TACTICAL LEVEL Surveillance  Reconnaissance  Combat Operations	Long-Range Surveillance Detachment LRSD, Division Troops, Battalion Reconnaissance, Cavalry Scouts Division Troops	DIVISION (Range dependent upon METT-T)

**Table 1-1. Operation strata.**

### 1-3. ARMY OPERATIONS DOCTRINE

The most pressing concern of a corps or division commander engaged in combat is knowledge of the enemy to his front or to his flanks, and how that enemy may affect his mission. The commander must surprise the enemy and catch him at a disadvantage as often as possible. To do so, the commander must see well forward and know the areas of operation and interest. He must also know the enemy's capabilities, strengths, location of reinforcements, density of air defense, and activities. This information is obtained through intelligence activities that provide the basis for tactical and operational decisions. Conduct of Army operations is based on timely intelligence from organic and higher sources at corps. Real-time human intelligence information is needed to complement electronic and imagery intelligence systems. The LRSUs at corps and division play an active part in the Army operations by providing that information. FM 100-5 states that success on the battlefield depends on all commanders knowing and implementing the five basic tenets of Army operations doctrine: initiative, agility, depth, synchronization, and versatility.

a. **Initiative.** Initiative sets or changes the terms of battle by action. It implies an offensive spirit in all actions. It means departing from planned

actions when an opportunity presents itself to hasten mission accomplishment. The LRSUs provide the corps and division commanders near real-time information on the enemy. This information does not need lengthy processing and analysis, thus enabling commanders to take the initiative when the opportunity presents itself.

b. **Agility.** Agility involves thinking and acting faster than the enemy. It involves the mental, command and control, and organizational ability to evaluate METT-T factors and then shift rapidly to destroy the enemy. The LRSUs provide commanders timely information that enables them to act swiftly and take advantage of the enemy situation. Because of the communication systems that LRSUs use, and mobility restrictions, LRS teams are not responsive to changes in the mission once deployed.

c. **Depth.** Depth is measured in time, distance, and resources. The commander uses available time and the depth of the battlefield to employ his forces to defeat the enemy. Depth is the greatest contribution of the LRSUs in Army operations. The units give corps and division commanders the ability to see deep into the enemy's rear.

d. **Synchronization.** Synchronization is teamwork and coordination of effort. The commander must know how the combined-arms team is used to defeat the enemy. Synchronization is a unity of effort following the commander's intent. This unity extends from the maneuver plan to the integration of CS and CSS assets to ensure mission accomplishment. Information provided by the LRSUs and integrated with other forms of information-gathering assets give the commander a coordinated effort and better understanding of the battlefield.

e. **Versatility.** Versatility is the ability of units to meet diverse mission requirements. Commanders must shift focus, tailor forces, and move from one role or mission to another rapidly and efficiently.

## Section II. MISSION

Surveillance is the primary mission of LRS operations. It is the mission that LRS teams are best equipped and trained to perform. Teams maintain surveillance for a specified period or until the required information is collected. Each team records all pertinent data.

### 1-4. CHARACTERISTICS

LRS teams are not special operations forces, but their doctrine, tactics, equipment, and techniques are similar. LRS team operations are characterized by the following.

- a. Clandestine operations require OPSEC procedures before, during, and after mission employment.
- b. Team members depend on stealth, cover and concealment, and infantry and ranger skills.
- c. Team members avoid contact with enemy forces and local population.
- d. Teams are employed to obtain timely information.
- e. Teams have restricted mobility in the area of operations.
- f. Team members depend on communications, knowing the enemy's order of battle, and equipment identification skills.
- g. The surveillance or reconnaissance area is small, has a specified route, or is a specific location or installation.
- h. Team equipment and supplies are limited to what can be man packed or cached.
- i. Teams require detailed intelligence preparation of the battlefield (IPB) from the G2 for employment.

### **1-5. MISSION EXECUTION**

Long-range surveillance operations are carried out by small, highly trained teams who infiltrate and exfiltrate contested areas by air (helicopter or fixed-wing aircraft), parachute, ground (vehicle or foot), water, or a combination of these methods.

a. During retrograde operations or withdrawal of covering forces in defensive operations, teams may be employed in a stay-behind mode. Once inserted, the teams in a stay-behind role set up a hide site that provides security, cover, and concealment. A surveillance site is then setup, normally during darkness or other limited visibility. The surveillance site is located where it can provide the most coverage of the specific point, route, or area to be observed. Contact is made between the surveillance site and the hide site primarily during limited visibility. In some situations, the hide and surveillance sites are combined. However, the surveillance site frequently obtains information that must be reported immediately. In such cases, a team member goes to the hide site to report the information or uses a tactical FM radio or landline. The long-range surveillance team should use the most secure means of communication available between the hide site and the surveillance site.

b. Combat information reported by the surveillance site is normally consolidated at the hide site. This information is sent to the LRSU operations section by secure, rapid HF or SATCOM devices. A data-burst transmission device enhances communication security and reduces transmission time. Messages are sent at predetermined times or as

immediate spot reports. To reduce the possibility of detection, teams use separate communication sites, directional antennas, and terrain masking techniques. Some areas may be monitored by sensor devices emplaced by the teams. These devices normally transmit their signals to a receiving station in the corps or division area.

### Section III. ORGANIZATION

A long-range surveillance unit may be a company or a detachment. This section discusses their organization, capabilities, and limitations.

#### 1-6. LONG-RANGE SURVEILLANCE COMPANY

The LRSC is organized as a company organic to the military intelligence brigade at corps (Figure 1-1). It consists of a headquarters platoon, communications platoon, and three LRS platoons—each consisting of six surveillance teams. The leaders are airborne and ranger qualified. All other personnel in the company are airborne qualified.

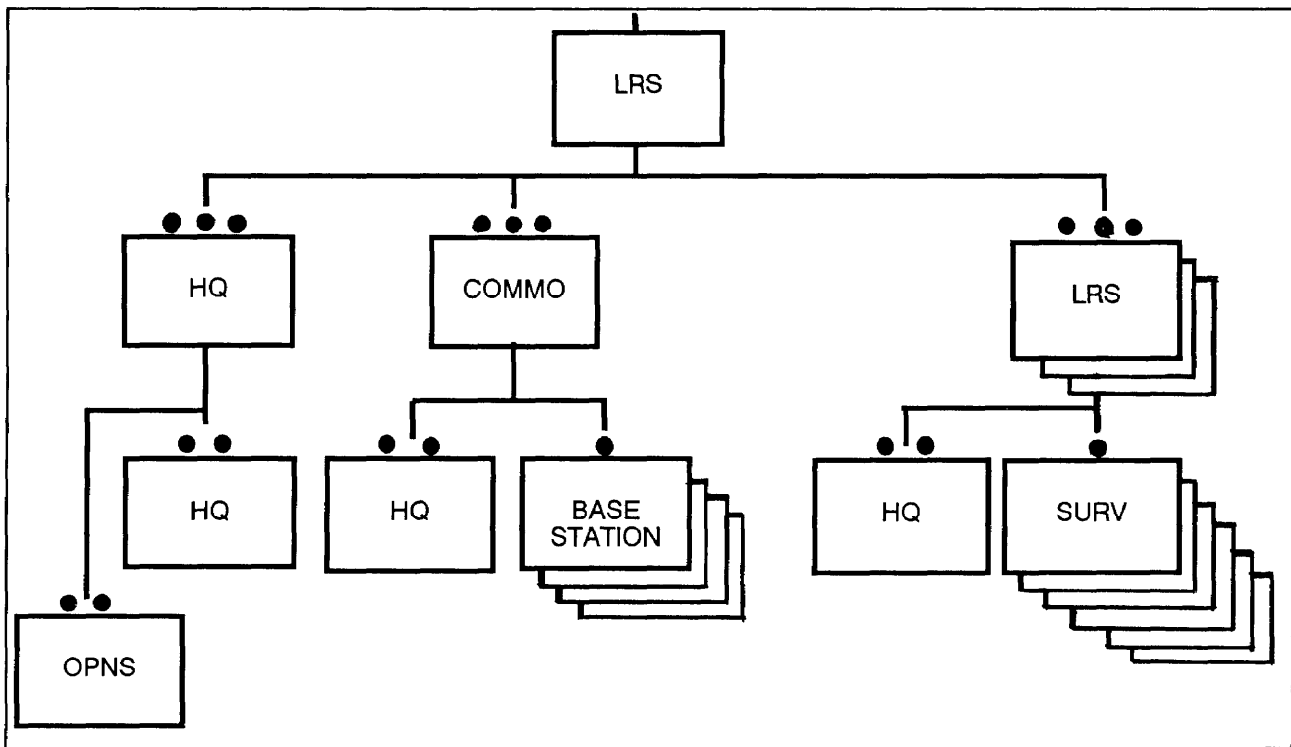

Figure 1-1. Long-range surveillance company.

a. **Headquarters Platoon.** The headquarters platoon contains two sections for the command and control of the company in the areas of administration, logistics, and operations.

(1) *Headquarters section.* This section contains the personnel necessary for the command and control of the company and supply support.

(2) *Operations section.* The personnel in this section plan and control the employment of the teams, coordinate insertion and extraction of the teams to include external support, receive and report information from committed teams, and maintain the operational status of all teams. Liaison duties and planning for future operations are important functions of the operations section.

b. **Communications Platoon.** The communications platoon operates the base radio stations. It helps the operations section plan and maintain communication with deployed teams. It works with the operations section or separately to relay information from deployed teams. It also performs unit maintenance on communication equipment organic to the unit. The platoon has a headquarters section and four base radio stations.

(1) *Headquarters section.* The personnel in this section establish command and control over assigned communications elements. They coordinate and set up communication procedures, transmission schedules, frequency allocation, and communication sites. They issue and control encryption code devices and materials. They ensure continuous communication between deployed teams and base radio stations. They provide communication support to detached LRS platoons. They augment division LRSDs with communication support when directed. They also provide unit maintenance for company communication equipment.

(2) *Base radio stations.* The four base radio stations maintain communication between the operations base and the deployed teams. They operate on a 24-hour basis to make sure all message traffic to and from teams is processed immediately.

c. **Long-Range Surveillance Platoon.** This platoon has a headquarters section and six surveillance teams.

(1) *Headquarters section.* This section contains the personnel necessary for command, control, and training of the platoon.

(2) *Surveillance teams.* Each team consists of a team leader, an assistant team leader, three observers, and a RATELO. The teams obtain and report information about enemy forces within the corps' area of interest. The teams can operate independently with little or no external support in all environments. They are lightly armed with limited self-defense capabilities. To be easily transportable, they are equipped with lightweight, man-portable equipment. They are limited by the amount of weight that they can carry or

cache. Because all team members are airborne qualified, all means of insertion are available to the commander when planning operations.

**1-7. LONG-RANGE SURVEILLANCE DETACHMENT**

The LRSD is organized as a detachment organic to the military intelligence battalion at division level (Figure 1-2). The LRSDs are organized into a headquarters section, communications section (two base radio stations), and six surveillance teams. (Light division LRS detachments only have four surveillance teams.) The leaders are airborne and ranger qualified. All other personnel in the detachment are airborne qualified.

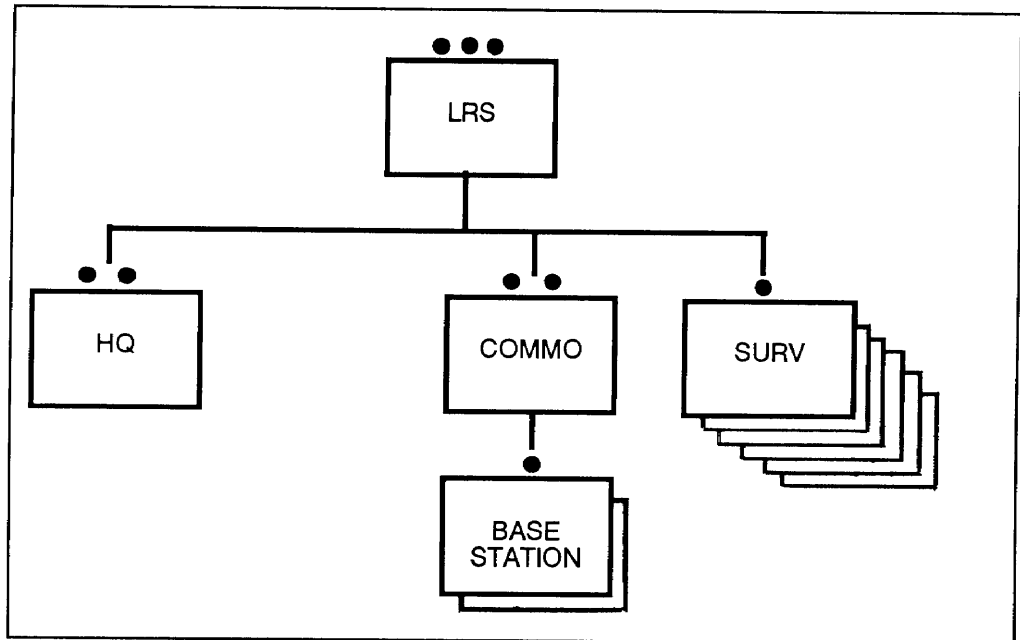

**Figure 1-2. Long-range surveillance detachment.**

a. **Headquarters Section.** This section contains the personnel necessary for command and control of the detachment.

b. **Communications Section.** These personnel ensure expeditious processing of all message traffic. The two base stations maintain communication with deployed teams. The LRSD may be augmented with a base station from the corps LRSC if dictated by operational requirements, equipment shortages, or maintenance problems.

c. **Surveillance Teams.** Each team consists of a team leader, an assistant team leader, three observers, and a RATELO. The teams obtain and report

information about enemy forces within their assigned areas. They can operate independently with little or no external support in all environments. They are lightly armed with limited self-defense capabilities. To be easily transportable, they are equipped with lightweight, man-portable equipment. The teams are limited by the amount of weight that they can carry or cache. Because all team members are airborne qualified, all means of insertion are available to the commander when planning operations.

### **1-8. CAPABILITIES**

The organization, strength, and equipment of teams are based on the mission and the environment of the operational area. Long-range surveillance units have the capability —

- To be committed in specific locations within enemy-held territory by stay-behind methods or delivery by land, water, or air, to include parachute. Units exfiltrate by land, water, or air.
- To operate in enemy-held territory for up to seven days with minimal external direction and support.
- To conduct surveillance, reconnaissance, target acquisition, and damage assessment missions in all types of terrain and environments.
- To establish communication using HF, VHF, UHF, or SATCOM between the base stations or the controlling headquarters and surveillance teams directly or through airborne relay.
- To conduct operations in bad weather and over difficult terrain.
- To be recovered by air, land, or water; to linkup with advancing forces; or to return using evasion techniques.
- To operate using planned, automatic resupply drops or special equipment cache sites set up by the LRSU or other friendly forces. They also use captured supplies and equipment.

### **1-9. LIMITATIONS**

Long-range surveillance units are limited by the following considerations.

- a. Mobility is restricted to foot movement in the area of operations.
- b. Teams cannot maintain continuous communication with the controlling headquarters because of equipment limitations and the enemy's use of radio and electronic surveillance devices. Teams only establish communication at scheduled times or to report critical combat information.

- c. organic medical capability is limited to individual first aid.
- d. Teams are lightly armed and have limited self-defense capabilities. They fight only to break contact.
- e. LRSUs require support from higher headquarters in —
  - Maintenance, supply, mess, medical, administration, finance, personnel, and chaplain services.
  - Area communication integration and access to a common-user telephone system.
  - Frequency management for HF and SATCOM access. Packing, rigging, and loading supplies and equipment for aerial resupply operations and parachute insertion operations.
  - Army or Air Force air transportation to move the LRSU to the area of operations and ground transportation (provided by the division support command or corps support command) to move personnel and organic equipment in the area of operations.
  - Intelligence (IPB) products from division or corps headquarters.

### 1-10. WEAPONS AND EQUIPMENT

LRS teams operate with little or no support once in the area of operations. Operations in the enemy rear area requires the teams to have modern, lightweight weapons and equipment to complete the mission.

a. **Weapons.** The LRSC and LRSD are lightly armed but have a variety of organic small-arms weapons. Based on specific mission requirements, the unit is task-organized to meet the needs of the teams. The teams try to avoid contact.

b. **Equipment.** The special equipment they need is as follows.

(1) *Communication.* Each LRS team has an HF radio with burst device for two-way communication with the base stations. Each team has emergency-distress radios (AN/PRC-90 or AN/PRC-112) if evasion becomes the means of exfiltration.

(2) *Observation.* LRS teams maintain observation of the objective at all times, in all kinds of weather. The LRS team has high-power day optics to aid in identifying enemy vehicles out to 5,000 meters. During limited visibility, the team identifies enemy vehicles out to 5,000 meters with both low-light amplification and infrared equipment.



(3) *Personal clothing and equipment.* LRS teams can operate in any environment when equipped with mission-specific items of clothing and equipment (for example, skis, winter clothing, and snow shoes for arctic areas.)

## CHAPTER 2

**FUNDAMENTALS**

*Long-range surveillance units use infantry and ranger skills combined with skilled communication operators and intelligence personnel to collect and report battlefield intelligence. The fundamentals of LRS operations are command and control, communication, mission development, and operational security.*

**Section I. COMMAND AND CONTROL**

Command and control (C2) is the process of directing and controlling military forces. For LRSU operations, C2 must be effective during all conditions, especially across the operational continuum with a special emphasis of operations conducted during the enemy's use of electronic warfare. (Figure 2-1.)

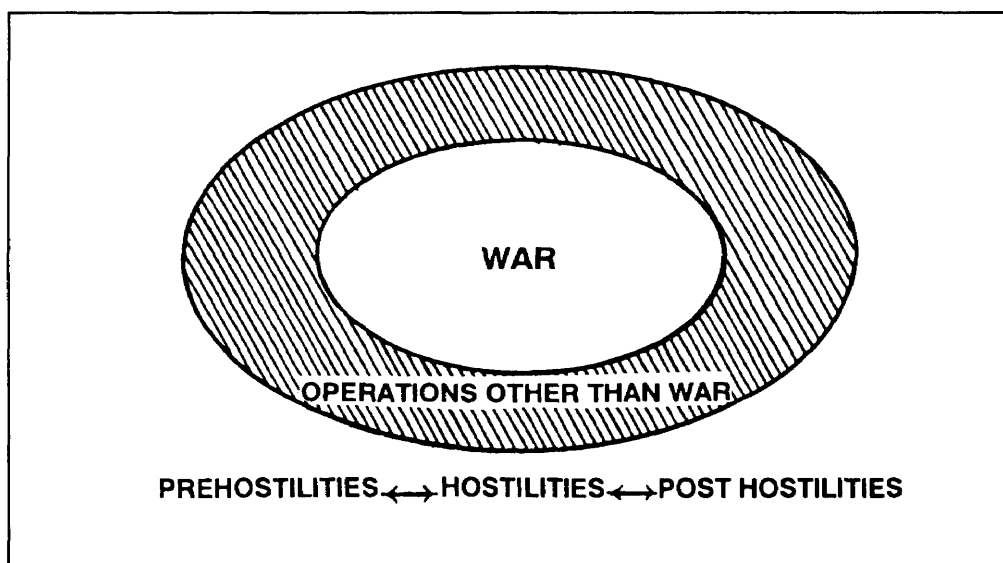

**Figure 2-1. Operational continuum.**

**2-1. STRUCTURE**

The LRSU's C2 system is structured for rapid deployment and collecting and reporting information. Communication, SOPs, and training to standard are critical to the success of C2.

a. The LRSC is organic to the tactical exploitation battalion of the military intelligence brigade. The corps G2 in coordination with other staff sections determines mission requirements for the LRSC.

b. The LRSD is organic to the MI battalion of the division. The division G2 in coordination with other staff sections determines mission requirements for the LRSD.

## **2-2. MISSION TASKINGS**

Efficient C2 allows the LRSC and the LRSD to respond quickly to mission taskings from the corps or division G2 (collection management and dissemination [CM&D] section). Missions assigned to LRSUs support corps and division commanders' priority intelligence requirements (PIR) and information requirements (IR) as stated in the collection plan. The commander's PIR govern the organization and conduct of reconnaissance, surveillance, target acquisition, and damage assessment operations. First priority usually goes to the information required for continuous operations. The faster the change in battlefield conditions, the more important reconnaissance, surveillance, target acquisition, and damage assessment operations become. The PIR serve to focus the unit's collection effort on the most important features of the enemy and terrain. Intelligence collection efforts provide the commander with a complete and accurate picture of the total battlefield. The PIR and IR are the basis for collection operations; they are analyzed by the all-source analysis section in conjunction with the IPB. The all-source analysis section develops indicators for each PIR and IR. (Indicators are any evidence of enemy activity or any characteristics of the area of operations that point toward enemy capabilities, vulnerabilities, or intentions.) From those indicators, statements or questions are derived that will satisfy specific information requirements (SIR). These questions or statements form the basis for specific LRS taskings. (For more information, see FM 34-8.)

a. Sound tactical planning and operations depend on intelligence. The corps and division G2s plan and coordinate collection capabilities and other intelligence functions to give corps and division commanders the ability to see and fight throughout the depth of the battlefield. The commander can then consistently make decisions faster than the enemy. The corps and division intelligence systems support operations by obtaining specific information required to confirm or deny indicators to satisfy the commander's PIR. The LRSU is tasked to collect information on surveillance targets to satisfy some of these SIR. The G2 ensures that assigned LRSU targets satisfy both PIR and IR and offer a reasonable chance of mission accomplishment and team survivability. Examples of possible targets are —

- Critical points along avenues of approach.
- Critical points along key lines of communication.

- Airfields.
- River fords.
- Bridges or rail junctions.
- Ordnance or logistical depots.
- Railroad yards.
- Known enemy command posts and headquarters.
- Assembly areas.
- Air base traffic.
- Economic activity.
- Political and propaganda activity.
- Drug processing or drug growing activity.
- Refuge flow.

In operations other than war, the tasking procedure does not change, but types of surveillance targets do. Targets in an operation other than war environment include infiltration routes, supply bases, training bases, and assembly areas.

(1) The corps G2 nominates LRSC missions, which are normally approved by the corps commander. The G2 ensures the LRSC missions support the collection plan and do not conflict with other collection efforts. Coordination with echelons above corps ensures that LRS operations are planned and coordinated with reconnaissance and strike capabilities (US and allied) that may be used in the corps area. The G2 then coordinates with the G3 to validate external support requirements. The CM&D section then tasks the LRSC. The corps CM&D section coordinates with subordinate division G2s and ensures that LRS operations do not conflict.

(2) The division G2 nominates LRSD missions, which are normally approved by the division commander. The division G2 ensures that LRSD missions support the collection plan and do not conflict with other collection efforts. He then coordinates with the G3 to make sure that the mission can be supported and does not conflict with other unit missions. The CM&D section then tasks the mission to the LRSD.

b. The G2 tasks the LRSU by input to paragraph 3 of the corps or division OPORD, FRAGO, or freetext message. (See Section III for LRS planning.) (See Figure 2-2.)

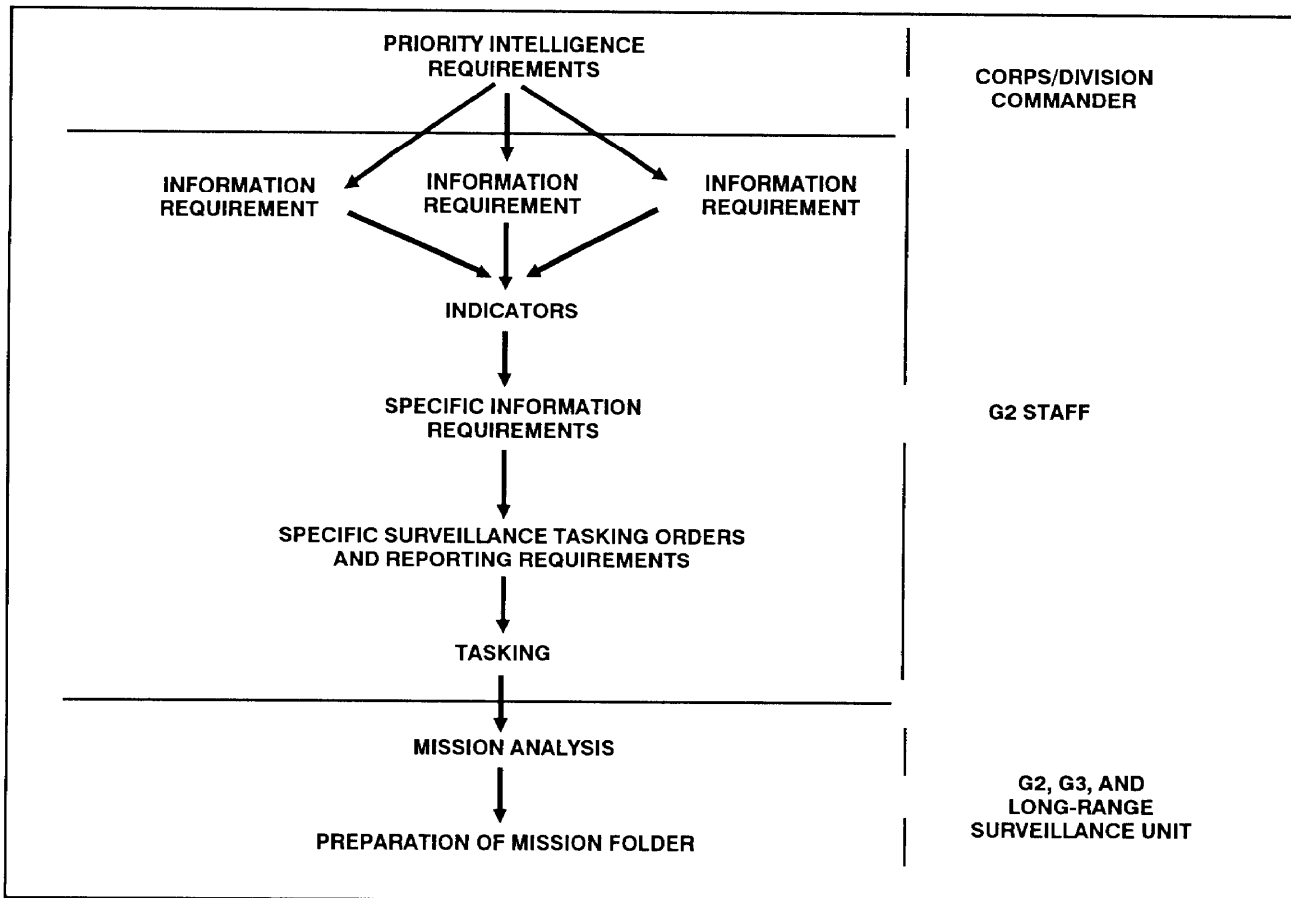

Figure 2-2. Long-range surveillance mission development sequence.

### 2-3. TYPES OF MISSIONS

LRSUs are tasked to conduct several different types of missions to satisfy G2 collection requirements. Although surveillance is the primary mission, LRSUs can also perform limited reconnaissance, target acquisition, and battle damage assessment. Weather and terrain conditions reporting is an inherent capability of LRSUs. LRSUs can also perform in limited collateral activities such as pathfinder operations and combat search and rescue operations. The individual unit METL defines the mission it must perform. Surveillance teams use stealth in conducting their missions. Movement within the target areas is limited to mission accomplishment. In restricted visibility conditions, observers may move closer to the target area. Surveillance teams can be assigned the following missions.

- a. **Surveillance.** Surveillance is the primary LRS mission. Surveillance sites are established using mission, enemy, terrain, and troops and time

available (METT-T) factors. Stand-off from the target is desirable, but METT-T factors may dictate the positioning of the surveillance site close to the objective. METT-T factors may also dictate multiple surveillance sites to compensate for daily changes in terrain, weather, and light. Surveillance is either maintained for a specified period or until the required information is obtained.

b. **Reconnaissance.** Surveillance teams can conduct limited reconnaissance missions. Reconnaissance missions are area, zone, and route. Movement by teams is minimized to avoid detection. (See Appendix B for specifics on reconnaissance.)

c. **Target Acquisition.** The detection, identification, and location of key enemy targets may be a mission of LRS teams. In addition to the acquisition of specific targets, teams may emplace sensors or other unattended devices.

d. **Damage Assessment.** The LRS team members are trained and equipped to conduct tactical damage assessment. They can conduct chemical and radiological monitoring if equipped.

e. **Terrain and Weather Reporting.** The LRS team can provide accurate terrain data and current weather conditions in and around potential targets. Human intelligence on current conditions helps greatly to ensure success of operations. (See Appendix C for information on operational environments.)

f. **Collateral Activities.** The LRS team can also conduct disaster relief, coalition support, combat search and rescue, and pathfinder operations.

## 2-4. LEADERSHIP

Leadership gives purpose, direction, and motivation in combat. A leader's competence and confidence results in effective unit action. A leader must know how to analyze the situation quickly and make decisions rapidly.

a. **Long-Range Surveillance Company.** LRSC leadership includes the company commander, executive officer, operations officer, intelligence officer, first sergeant, liaison noncommissioned officer, chemical noncommissioned officer, communications platoon leader, surveillance platoon leaders, platoon sergeants, and team leaders.

(1) *Company commander.* The company commander is responsible for the tactical employment, training, administration, personnel management, and logistics of the company. He does this by planning, making timely decisions, issuing orders, assigning tasks, and supervising company activities. He must know the capabilities of his surveillance teams and how to use them. He must also know the capabilities of the units supporting the company. He exercises command through his executive officer, operations officer, platoon leaders, and first sergeant. He employs the company based on missions and

taskings from the corps G2 CM&D and on his consideration of METT-T. He prepares plans with help from his operations section. He stays abreast of the situation at all times. The commander maintains close coordination and liaison with the military intelligence brigade tactical operations center (TOC) and corps TOC.

(2) *Executive officer.* The executive officer is the administrative and logistical coordinator for the company. He coordinates supply, maintenance, medical, and mess support. He also supervises the operation, movement, security, internal arrangement, and organization of the company operations base (COB). The executive officer works closely with the operations officer, operations NCO, first sergeant, supply sergeant, communications platoon leader, and communications chief. He keeps abreast of the tactical situation.

(3) *Operations officer.* The operations officer is the main planner and coordinator for the company. He plans in detail the employment of the teams. He coordinates the efforts of the operations section in controlling the execution of team missions. He stays abreast of the tactical situation and advises and assists the company commander.

(4) *Intelligence officer.* The intelligence officer is directly responsible for all intelligence training within the company. He must devote specific attention to enemy recognition and order of battle training to help the surveillance teams provide accurate combat information. He assists the operations officer in briefing and debriefing surveillance teams. He task-organizes company intelligence personnel to maintain a 24-hour capability.

(5) *First sergeant.* The first sergeant is the senior NCO in the company. He advises the commander and assists him by performing assigned duties to include supervising unit administration, training, logistics, and maintenance activities. He recommends appointments, promotions, reductions, assignments, and disciplinary actions pertaining to NCOs and enlisted soldiers to the commander. He also assists the executive officer in CSS functions.

(6) *Liaison noncommissioned officer.* The liaison NCO represents the company at higher, supporting, and other headquarters. Through his knowledge of LRS operations and the status of his unit, he coordinates support of ongoing and planned operations, advises, and exchanges essential information.

(7) *Chemical noncommissioned officer.* The chemical NCO assists the commander in planning and conducting operations in an NBC environment. His assistance primarily includes team training in the area of NBC survival, tactical damage assessment, and chemical and radiological monitoring.

(8) *Communications platoon leader* The communications platoon leader is the communications planner and coordinator. He keeps abreast of the status of communications personnel and equipment. He is responsible for the tactical employment, training, administration, personnel management, and logistics of his platoon. He advises the commander on matters pertaining to communication security (COMSEC), electronic counter-countermeasures (ECCM), and signal training of the company. He decides and coordinates the location for the alternate operations base (AOB). He disseminates information from current signal operating instructions (SOI) and makes sure that each team radiotelephone operator is briefed before and debriefed after each operation. He identifies, coordinates, and requests external communication and COMSEC support through his MI battalion signal officer.

(9) *Surveillance platoon leader.* The surveillance platoon leader is responsible for the training, administration, personnel management, and logistics of his platoon. He details teams for assigned missions and makes sure they are available and ready. He assists in the infiltration and exfiltration of his surveillance teams as directed. He accompanies team leaders during aerial reconnaissance and assists in selecting landing zones (LZs), drop zones (DZs), and pickup zones (PZs). During insertion, he flies in the command and control aircraft and exercises overall control of the insertion. He may be required to conduct extractions. He can also serve as a liaison when his platoon is task-organized to another unit.

(10) *Platoon sergeant.* The platoon sergeant is the senior NCO in the platoon. He advises the platoon leader and helps him with administration, training, logistics, and maintenance activities. He recommends appointments, promotions, reductions, assignments, and disciplinary actions as they pertain to NCOs and enlisted soldiers. He keeps abreast of the tactical situation, and he is prepared to assume platoon leader responsibilities, if required.

(11) *Team leader.* The team leader is responsible for the tactical employment, training, administration, personnel management, and logistics of his team. He does this by planning, making timely decisions, issuing orders, assigning tasks, and supervising team activities. He must know the capabilities of his team members and supporting units. He is a key man in the planning, preparation, and execution of LRS missions. Success depends largely on how well he performs and influences the performance of his team. He must be alerted early in the planning stage to allow time for him to complete necessary actions.

b. **Long-Range Surveillance Detachment.** The LRSD leadership includes the detachment commander, executive officer, detachment



sergeant, detachment communications sergeant, detachment operations sergeant, base radio station section chief, and team leaders.

(1) *Detachment commander.* The detachment commander is responsible for the tactical employment, training, administration, personnel management, logistics, and maintenance of the detachment. He does this by planning, making timely decisions, issuing orders, assigning tasks, and supervising detachment activities. He must know the capabilities of his detachment and how to tactically employ them. He must also know the capabilities of the CS and CSS units supporting the detachment. He exercises command through his team leaders, base radio station section chiefs, and detachment sergeant. He employs the detachment based on missions and taskings from the division G2 CM&D. He maintains close liaison with the staff of the headquarters to which he is assigned, to include participation in mission planning. He stays abreast of the situation at all times and locates where he can best influence the action.

(2) *Executive officer.* The executive officer is the administrative and logistical coordinator for the detachment. He coordinates supply, maintenance, medical, and mess support. He also supervises the operation, movement, security, internal arrangement, and organization of the detachment operations base (DOB). The executive officer works closely with the operations NCO, detachment sergeant, supply sergeant, and detachment communications sergeant. He keeps abreast of the tactical situation.

(3) *Detachment first sergeant.* The detachment first sergeant advises the commander and assists him by performing assigned duties to include supervising unit administration, logistics, and maintenance activities. He is also the primary unit trainer. He recommends appointments, promotions reductions, assignments, and disciplinary actions pertaining to NCOs and enlisted soldiers to the commander. He also assists the executive officer in CSS functions. He keeps abreast of the tactical situation.

(4) *Detachment operations sergeant.* The detachment operations sergeant assists the commander in planning and coordinating for the detachment. He plans in detail the employment of the teams, and he coordinates the efforts of the headquarters section in controlling the execution of team missions. He stays abreast of the tactical situation and advises and assists the detachment commander. He develops, reviews, and reproduces graphics.

(5) *Detachment communications sergeant.* The detachment communications sergeant plans and coordinates all communications for the detachment. He maintains the status of the communications equipment and personnel in the detachment. He is responsible for the tactical employment,

training, administration, personnel management, and logistics of all communications assets. He advises the commander on matters concerning COMSEC, ECCM, and signal training of the detachment. He disseminates information from the SOI and makes sure each team RATELO is briefed before and debriefed after each operation. He identifies, requests, and coordinates all external communications and COMSEC through his MI battalion signal officer. He recommends to the commander and coordinates the location for the AOB.

(6) *Base radio station section chief.* Each section chief is responsible for the tactical employment, training, administration, personnel management, and logistics of his base radio stations. He coordinates with the detachment commander for the employment of his base radio stations and the communications requirements for each operation. He coordinates administrative and logistical support with the detachment sergeant.

(7) *Team leader.* The team leader is responsible for the tactical employment, training, administration, personnel management, and logistics of his team. He does this by planning, making timely decisions, issuing orders, assigning tasks, and supervising team activities. He must know the capabilities of his team members and supporting units. He is a key man in the planning, preparation, and execution of LRS missions. Success depends largely on how well he performs and influences the performance of his team. He must be alerted early in the planning stage to allow time for him to complete necessary actions.

## **2-5. SURVEILLANCE TEAM OPERATIONS**

Long-range surveillance teams operate within the area of operations of their respective corps or division.

a. The specific operational area is identified and coordinated for each mission. The target, in conjunction with the insertion and extraction plan, determines the area in which a team operates. This area is not so large that it unduly restricts the employment of corps or division assets, but it is large enough to give the team flexibility. LRSD teams are employed forward of the forward edge of the battle area in the division area of operation. The LRSC teams are employed in the corps area of operation forward of the detachment teams. The distances LRSD and LRSC teams operate forward of the forward edge of the battle area vary depending on terrain, operational tempo of the battlefield, and intelligence needs of the commander. (See Figure 2-3.)

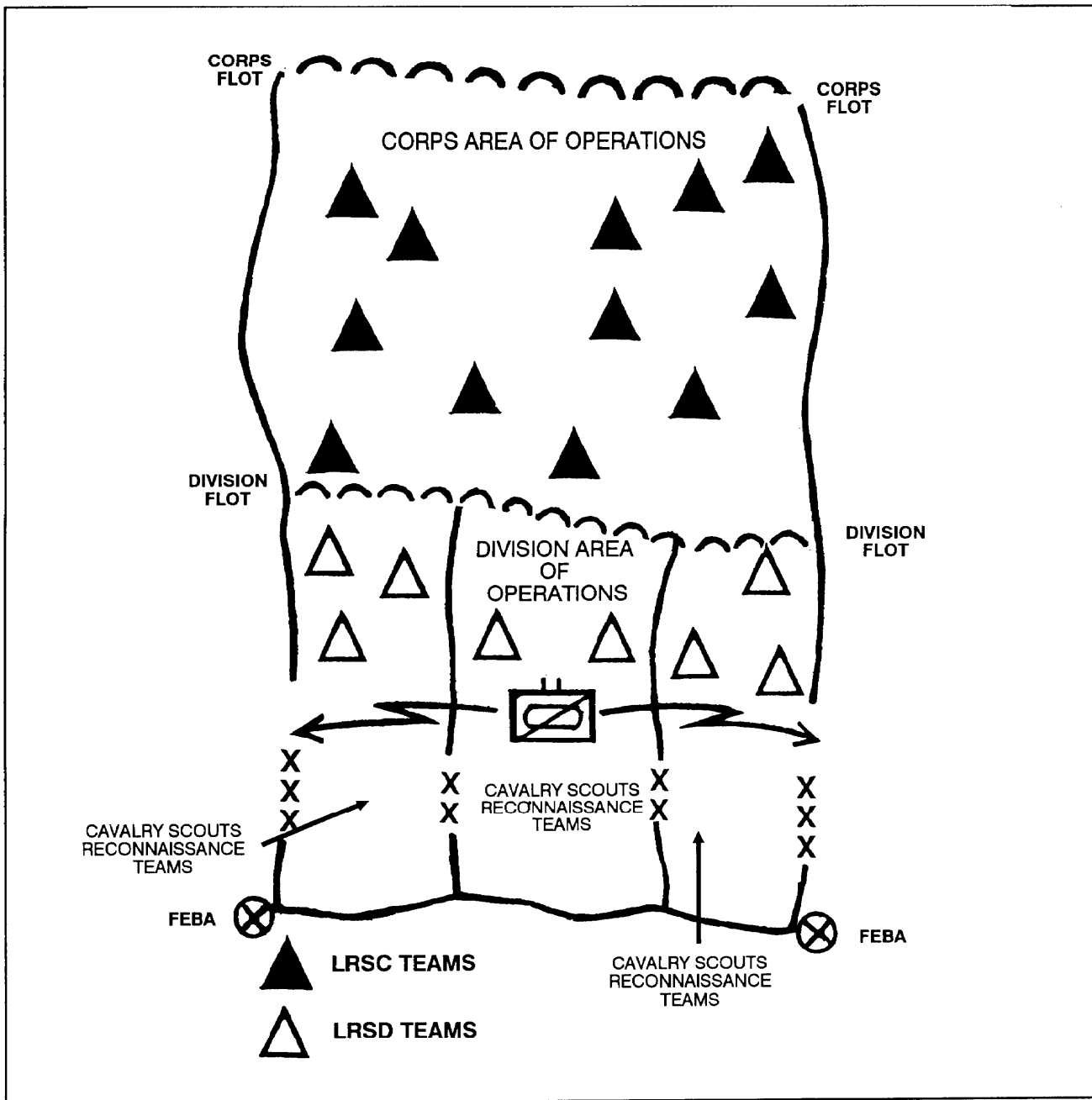

Figure 2-3. Areas of operations.

b. Operations by teams in areas forward of friendly soldiers can create possibilities for fratricide. To protect the LRS teams from friendly fires, the following coordination is conducted before insertion.

(1) Hide site and surveillance site locations are normally included in coordination of restricted areas (no-fire areas) established by the controlling headquarters. The controlling headquarters informs higher, lower, and adjacent headquarters of the no-fire areas. For security reasons, the nature of the mission is not normally stated and additional dummy or false no-fire areas are added to reduce the signature of the LRS teams. To maintain operation security, all no-fire areas are listed as on order.

(2) Teams may operate in areas in which fires cannot be restricted. In such instances, the committed team is briefed on known strikes and warning procedures of impending friendly fires, air strikes, and nuclear and chemical operations.

(3) Detailed planning is required in situations where an LRS team may link up with advancing friendly units. The team must be familiar with general linkup procedures. As details become available, the commander informs the team of frequencies, call signs, and code words. The LRS team is normally the stationary element. The linkup unit is briefed to the lowest level possible. A liaison team is sent from the company operations base or detachment operations base or alternate operations base (AOB) to ensure that this coordination takes place. Once linkup has occurred, the team debriefs the S2 of the linkup unit. This ensures that information gets to the organization that needs it the most. The team is then expedited to the COB or DOB for further debriefing and refitting operations.

(4) Detailed planning is required if the team must infiltrate or exfiltrate by foot. Formal passage of lines coordination is essential to prevent fratricide. A liaison team from the COB, DOB, or AOB provides assistance and information to the team or the friendly forward unit.

(5) The G2 normally coordinates with other reconnaissance or surveillance assets to reduce the risk of fratricide.

## **2-6. OPERATIONS BASE**

The operations base is a location from which the LRSC or the LRSD operates. (See Figure 2-4, page 2-12, for an example long-range surveillance company or detachment operations base.) The LRSC operations base locates with or near the CM&D section of the corps G2. The LRSD operations base locates with or near the CM&D section of the division G2.

a. The operations base for the LRSC and the LRSD are similar. They include areas for a TOC, company or detachment headquarters, communications platoon or base radio station, motor park, isolation facility or area, LZ, and platoon or team defensive areas.

b. The primary mission of the AOB is to act as communication relay for the COB or DOB and deployed LRS teams. The AOB planning

considerations are based on communication requirements of the COB or DOB and the deployed LRS teams.

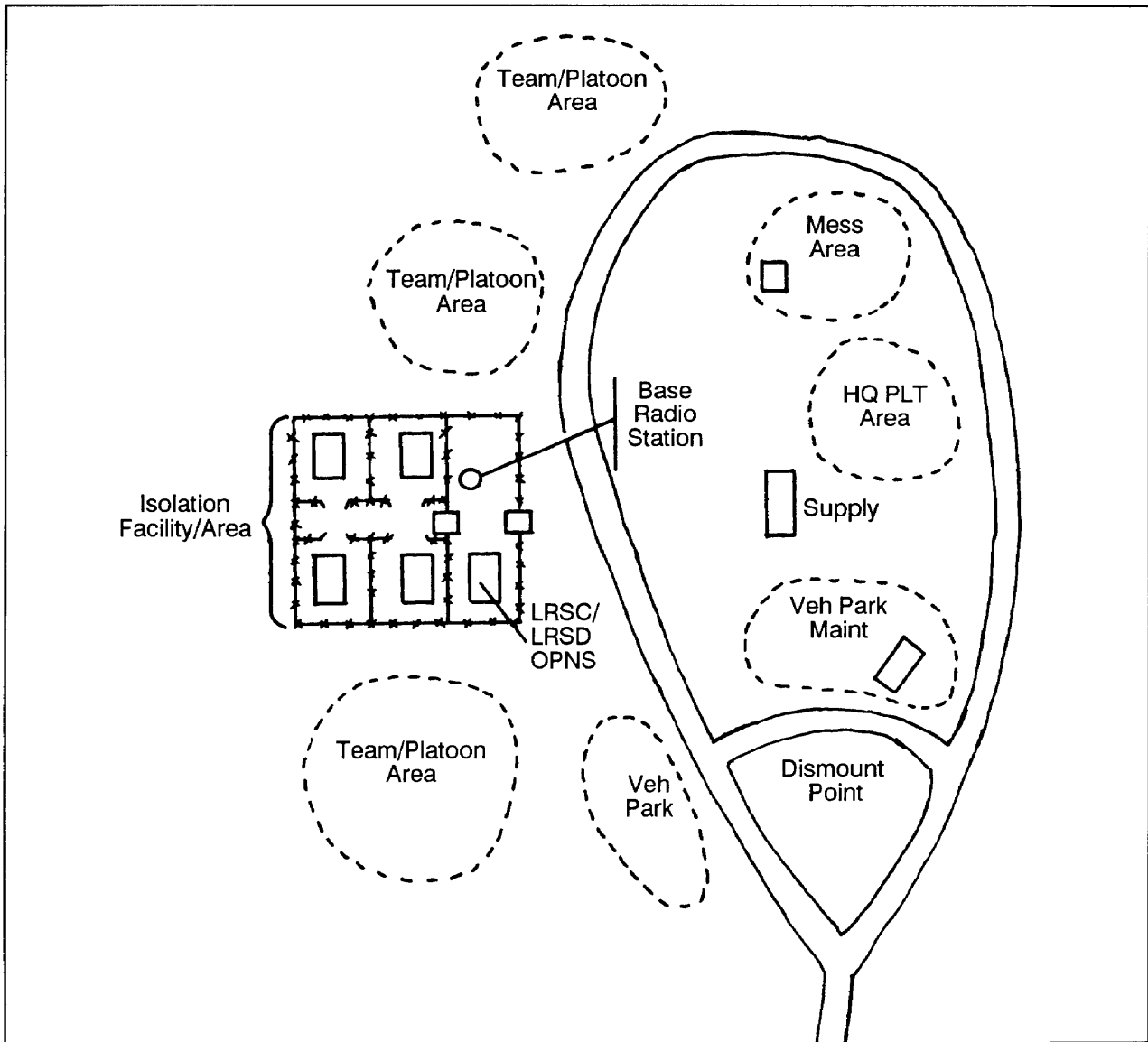

**Figure 2-4. Example long-range surveillance company or detachment operations base.**

(1) The AOB for the LRSC locates with or near the corps rear main, corps artillery headquarters, corps MI brigade, or MI tactical exploitation battalion headquarters. The LRSC AOB can also locate with an LRSD for specific operations requiring coordination or information exchange with a

division. A base station from the LRSC AOB, as part of a liaison team, can locate with a brigade for linkup operations.

(2) The AOB of the LRSD locates with or near the division rear main, the division artillery TOC, MI battalion TOC, or with the COB or LRSC AOB. The LRSD AOB moves toward the rear of the area of operations so it can relay communication between the deployed teams and the DOB. The AOB can locate with the division tactical command post when communication with the deployed teams and the DOB is reliable. A vehicle from the LRSD AOB, as part of a liaison team, can locate with a brigade for linkup operations.

c. The company commander selects the general location of the LRSC COB and AOB.

(1) The company executive officer decides the exact location of the operations base based on the commander's guidance. He supervises the setting up of both the operations base and security.

(2) The operations section sets up the company TOC. The company TOC is a secure, restricted-access area. In addition to the TOC, the operations section prepares and marks an LZ near the operations base. The LZ is normally controlled by the assistant operations NCO; however, during some operations, a team may be tasked to set up and control the LZ.

(3) Each surveillance platoon is assigned a platoon area within which it sets up a platoon CP. When a team is deployed, the platoon sergeant provides for security in the team area and for equipment not required for the mission.

(4) The communications platoon is assigned a working area where it sets up and operates the company wire net and provides communication equipment maintenance and logistical support. The communications platoon establishes a circuit to the nearest switchboard with access to the corps switching system.

(5) The company headquarters is assigned an area from which it provides administrative and logistical support as required. The executive officer initiates and enforces the operations base security plan.

d. The detachment commander coordinates a location at or near the division main command post for the DOB. He also selects the general location for the AOB.

(1) The detachment executive officer determines the best location within the command post for the detachment headquarters, base radio station, and surveillance teams.

(2) The operations section sets up the detachment TOC. The detachment TOC is a secure, restricted-access area. In addition to the TOC, the operations section prepares and marks an LZ near the operations base.

The LZ is normally controlled by the operations NCO; however, during some operations, a team or the communications section is tasked to set up and control the LZ.

(3) Each surveillance team is assigned an area within which it sets up a team CP. When a team is deployed, the detachment sergeant provides security for the team area and equipment not required for the mission.

(4) The communications section is assigned a working area where they set up and operate the detachment wire net and provide communication equipment maintenance and logistical support. The section establishes a telephone circuit to the nearest division switchboard to provide access to the division switching system.

(5) The detachment headquarters is assigned an area from which it provides administrative and logistical support as required. The executive officer initiates and enforces the operations base security plan.

## 2-7. TACTICAL OPERATIONS CENTER

The LRSC and the LRSD TOCs set up in the operations base. They give LRSU commanders a command and control capability and a communication with higher headquarters capability.

a. **LRSC TOC Organization and Responsibilities.** In the LRSC TOC, personnel perform specific functions as follows.

(1) *Operations officer.* The operations officer is responsible for the operation of the TOC. He plans and coordinates the company's tactical operations based on the commander's guidance. He also —

- Analyzes assigned missions, plans employment of teams, and prepares or approves operation orders before they go to the commander.
- Keeps the commander informed of current and projected tactical situations at all times.
- Supervises the preparation of all operational and intelligence documents.
- Supervises coordination with higher and supporting headquarters.
- Reports the operational status of committed and uncommitted LRS teams.

(2) *Assistant operations officer.* The assistant operations officer assumes responsibility for the TOC in the absence of the operations officer. He also —

- Makes sure that the current situation is posted on all maps and charts.

- Forwards combat information from the LRS teams to higher headquarters.
- Approves all situation reports and other status reports in the absence of or at the direction of the operations officer.
- Maintains the operations workbook.
- Approves the TOC personnel work schedule.
- Ensures preparation of the briefing area and maps.
- Plans and coordinates training for platoons and sections during temporary lags in operations.
- Posts the mission planning chart.
- Acts as a shift leader to maintain a 24-hour capability.

(3) *Operations sergeant.* The operations sergeant supervises the TOC enlisted personnel and assumes responsibility for the TOC in the absence of the operations officer and the assistant operations officer. He also —

- Helps prepare and edit all tactical operations plans.
- Supervises the operation of the detailed planning area.
- Posts the current situation on the friendly situation overlay and ensures that current information received from deployed teams is posted on the mission status charts.
- Establishes the TOC personnel work schedule.
- Coordinates with the first sergeant for TOC messengers and guards.
- Makes sure that only authorized personnel have access to the TOC.
- Posts the manning chart.
- Prepares the situation report for the period.
- Assists the assistant operations officer in maintaining the operation workbook.
- Acts as a shift leader to maintain a 24-hour capability.

(4) *Intelligence officer.* The intelligence officer is responsible for the intelligence personnel in the TOC. He also —

- Maintains a data base and map base sufficient to support the general area studies and the mission-specific detailed planning of LRS teams.



- Collects combat information for LRS team operations and keeps mission folders updated after they are received from G2.
- Provides intelligence input of the enemy situation for operation orders.
- Posts and maintains the enemy situation overlay.
- Assists the operations officer in briefing and debriefing LRS teams.
- Keeps LRS teams informed of critical information impacting on missions.
- Conducts final security inspections of LRS teams before deployment.

(5) *Intelligence sergeant.* The intelligence sergeant assists the intelligence officer in collecting combat information for LRS team operations and assumes responsibility for the TOC and the planning area in the absence of the operations sergeant. He also —

- Posts the enemy situation overlay in the absence of the intelligence officer.
- Assists the operations personnel in ensuring that security and OPSEC measures are followed within the TOC and the planning area.
- Briefs and debriefs LRS teams with operations personnel as directed by the intelligence officer.
- Splits shifts with the intelligence officer to maintain a 24-hour capability.

(6) *Assistant operations sergeant.* The assistant operations sergeant coordinates air support with US Army aviation or USAF units supporting team operations. He also —

- Assists the operations sergeant.
- Maintains a list and an overlay showing locations and descriptions of possible LZs, DZs, and PZs.
- Coordinates requests for airborne and air movement insertions, extractions, and visual reconnaissance with aviation support units.
- Posts the schedule of infiltration and exfiltration operations.

(7) *Chemical NCO*. The chemical NCO assists in establishing, administering, and applying defensive NBC operations. He also —

- Supervises preparation of NBC reports, maintenance of NBC supply, and unit and individual NBC training records.
- Collects, interprets, analyzes, and disseminates chemical information and data.
- Serves as principal NCO of the NBC defense team.

(8) *Liaison NCO*. The liaison NCO coordinates operations with supported and adjacent units, higher headquarters, and US Army aviation or USAF units.

b. **LRSD TOC Organization and Responsibilities.** In the LRSD TOC, the commander, executive officer, detachment sergeant, operations sergeant, and communications personnel perform all functions.

c. **Operations (LRSC or LRSD).** Before each mission, the TOC personnel (operations, intelligence, and communication) are prepared to —

- Present a detailed briefing to the team leaders on the specific area of operations.
- Coordinate infiltration and exfiltration operations.
- Assist the team leaders in coordinating fire support, aviation assets, resupply, and so forth.
- Receive pre-mission briefbacks from committed teams.

(1) *Ongoing actions*. During the mission, the TOC personnel monitor the progress of surveillance teams and are prepared —

- To coordinate resupply for committed teams.
- To coordinate emergency extractions.
- To coordinate medical evacuations.
- To coordinate other required support.
- To plan and coordinate additional missions as directed by the commander.
- To monitor scheduled communication times.
- To coordinate for friendly or partisan linkups by sending updated situation reports and any changes to the LRS team's mission; receiving, decoding, and disseminating combat and administrative information from the teams; and monitoring the guard frequency 24 hours a day.

(2) *Debriefing.* Immediately after exfiltration, TOC personnel debrief each surveillance team. G2 personnel conduct the debriefing, if available. The LRSC communications platoon leader or LRSD communication section sergeant debriefs the team RATELO.

(3) *Messages.* The TOC duty officer or NCO provides a receipt for all incoming messages. Other requirements are as follows:

- A receipt of each message is recorded in the staff journal.
- Information from each message is posted to the appropriate maps and charts.
- Each message is filed in the journal file according to the journal entry number.
- All outgoing messages originate from the TOC and are recorded in the journal.
- Intelligence reports are forwarded from the teams to G2 as necessary.

(4) *Journal.* The staff journal is a chronological record of events pertaining to the unit during a given period. The TOC duty officer or NCO maintains the journal.

(a) All items are cross-referenced to the journal entries by journal item number.

(b) All messages are posted to the journal with the following information noted:

- The sender.
- The title of the message or a description of the event.
- The time of receipt of the message.
- The journal item number and message center number (if applicable).
- The action taken.
- The initials of the person making the entry.

(5) *Security.* Personnel access to the TOC and the predeployment detailed planning area is restricted and controlled. SOP establishes procedures for control and identification of visitors.

(a) The TOC and the detailed planning area should have only one entrance.

(b) Appropriate security measures are taken in the safeguarding and handling of all classified material to include a well-rehearsed emergency destruction SOP.

(6) *Displacement*. When directed to displace, the on-duty shift continues to operate; the off-duty shift breaks down all equipment and loads it on the vehicles. The COB or DOB notifies the AOB of the departure time and route and the proposed relocation site. The AOB continues to monitor committed teams. When the COB or DOB is once again operational, the AOB sends an update.

## 2-8 TASK ORGANIZATION

The LRSCs and LRSDs assigned to corps organizations use the same company-level SOPs and communication procedures. Therefore, the corps commander can task-organize LRS assets as battlefield conditions change. LRSC and LRSD teams initially are employed in their respective areas of interest. The rapid pace of operations may require the LRSC and LRSD to coordinate command and control of deployed LRS teams and exchange information to meet the intelligence needs of the commander.

a. **Echelons Above Corps**. During retrograde operations, command, control, and communications of LRS teams beyond the corps area of operations is given to echelons above corps. This action requires a liaison with a radio station from a LRSU AOB to locate with echelons above corp controlling headquarters. Control of extracted teams is returned to the parent LRSU.

b. **Brigade Task Organization**. An LRSD, or portions of an LRSC, are under operational control of a brigade for certain operations. This OPCON occurs as part of a contingency operation. It most often occurs in an operation other than war environment and before the main control cell of the G2 deploys to the area of operations. It also occurs when brigades expand control of a sector and deployed LRS teams are operating in that sector. When this situation occurs, a liaison with a base radio station from the COB, DOB, or AOB locates with the brigade TOC. A G2 CM&D liaison may accompany the LRS control element for mission planning.

## Section II. COMMUNICATIONS

The accurate and timely reporting of information by the surveillance teams is the most important aspect of the LRSU mission. Without communications, there is no reason to insert a team deep into the enemy's rear area. Well thought out, planned, and practiced communication procedures helps ensure the success of a mission. Communication is a two-way event and everyone must know the procedures.

## 2-9. COMMUNICATION NETS

The LRSU team deploys out of line-of-sight communication range. Ordinary combat net radio systems cannot support the reporting requirements of the LRSU. Tactical FM radios, like single-channel ground and airborne radio system, must be in sight of each other electronically to communicate.

a. LRSUs must rely on and train with communication systems with extended range capabilities. Two systems available in the Army system are HF and tactical satellite radios.

(1) An HF radio is a reliable communication system with an unlimited range. Manpack improved, high-frequency radios like the AN/PRC-104 have simplified HF radio communication and increased reliability. HF communication requires extensive training and frequency management. The right frequency must be chosen for each communication scenario, and the right antenna must be built to satisfy each transmission path. (See Appendix D for more information.)

(2) Tactical satellite radio is a reliable communication system with an unlimited range. Tactical satellite radios come in manpack versions. However, satellite channels and tactical satellite radios are in short supply and high demand. The priority for tactical satellite circuits goes to echelons above corps and other strategic operations. The LRSU normally does not have access to circuits on a tactical satellite system.

b. The COB or DOB and their respective AOBs maintain communication with employed teams using HF radio. Each team has a separate frequency and cryptographic for OPSEC purposes. Communication between the two operations bases is maintained using the tactical switching system between the two locations. Backup communication between the base operations is maintained using either line-of-sight or HF radio systems as METT-T requires. The LRSC communication net has 18 teams and eight AN/TSC-128s. Figure 2-5 shows the LRSD communications net.

c. The COB or DOB maintains communication with their G2s using the tactical switching system and with combat net radio in the corps or division intelligence net.

d. Communication within the operations bases is accomplished with an internal wire net (Figure 2-6, page 2-22). The unit's communication personnel establish this net using organic wire and telephones.

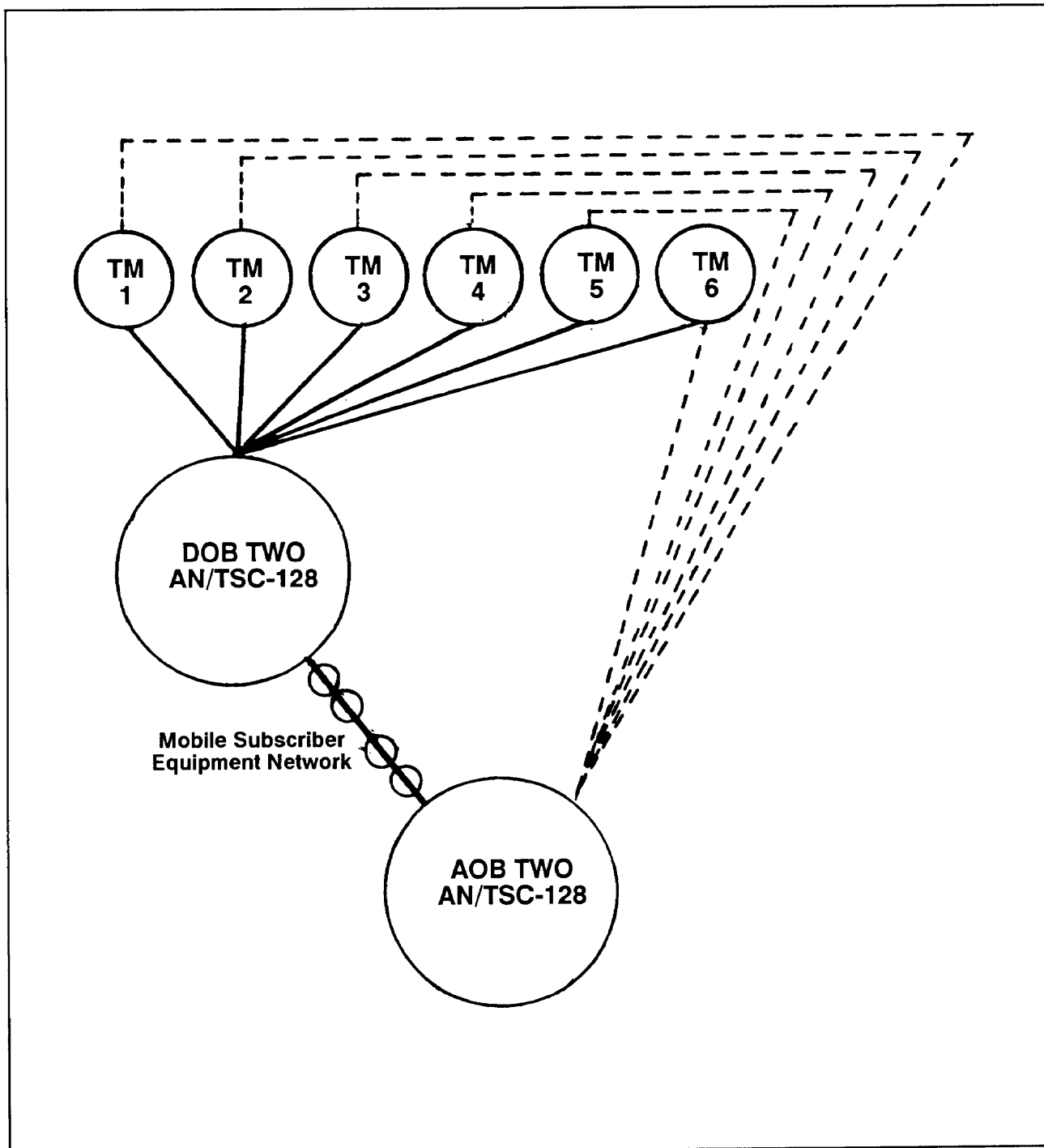
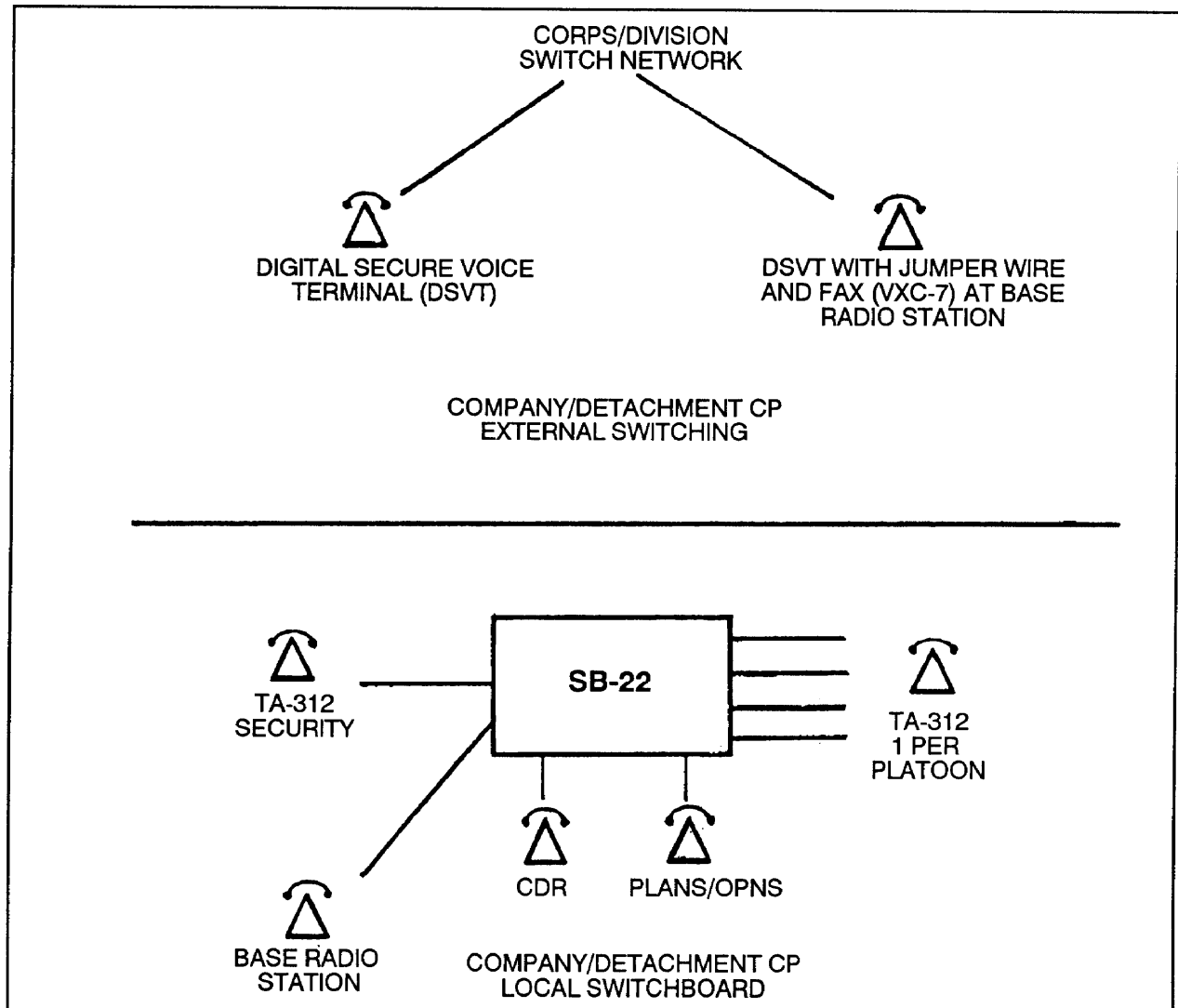

Figure 2-5. LRSD communications net.



**Figure 2-6. Internal wire net.**

**2-10. MESSAGES AND REPORTS**

The base radio station communicates with teams during specified communication times. A separate time is established for each team. The number of scheduled times used by the LRSU depends on METT-T. The employed team must be protected from enemy interception and direction finding. Too many scheduled times put a team at risk, while not enough scheduled times could minimize the importance of time-sensitive intelligence. OPSEC demands must be weighed with frequency availability.

a. In addition to scheduled communication times, an HF guard frequency is established. The base radio station monitors the guard

frequency 24 hours a day. The guard frequency provides the teams with a second frequency for transmitting outside the scheduled time, when communication on the primary frequency cannot be established. The guard frequency changes periodically to accommodate changes in the atmosphere, but changing it more than twice a day is not recommended; one frequency for daytime operation and one for nighttime operation is suggested. Instances where a team may use the guard frequency include —

- Report PIR.
- Request for extraction or fire support, because the team has been compromised.
- Request for medical evacuation.
- Start of evasion and escape.

b. The base radio station and teams communicate using data-burst devices; for example, the OA-8990 digital message device group (DMDG) and the KL-43C. A data-burst device sends messages over the radio as quickly as possible. The shorter the transmit time, the less likely a team will be detected by enemy direction-finding equipment. Interception is also a major concern of the LRSU. Data-burst devices do not preclude the enemy from intercepting the radio traffic. To minimize the effectiveness of enemy interception, teams and the base radio station encrypt messages. The DMDG has no internal cryptographic capability, so teams use a one-time pad with a trigraph to encode messages before sending them. The KL-43C has an internal cryptographic capability and does not require the team to manually encrypt the message. In addition to encrypting the message, teams can use brevity codes to assist in shortening the message. However, brevity codes increase the message processing time and increase the possibility for error.

c. Message formats between teams and the base radio station are part of the SOP. If a message has an exacting format, even a partially received message is useful, because it is recognizable. The following is an example of the messages a team should be prepared to transmit during a mission. (See Appendix D for illustrations.) (See the Special Forces SOI supplemental instructions for additional message formats.)

- ANGUS—Initial entry report.
- BORIS—Spot intelligence report.
- CYRIL—Situation report.
- UNDER—Cache report.
- WESAW—Ground order of battle report.



d. Intelligence reports received by the base radio station go directly to the corps or division G2. The LRSU operations base does not delay or change any intelligence report. If a message is received by the base radio station at the AOB and not the COB or DOB, the message is sent by the fastest, secure means to the corps or division G2 and the COB or DOB exactly as received. (See Figure 2-7.)

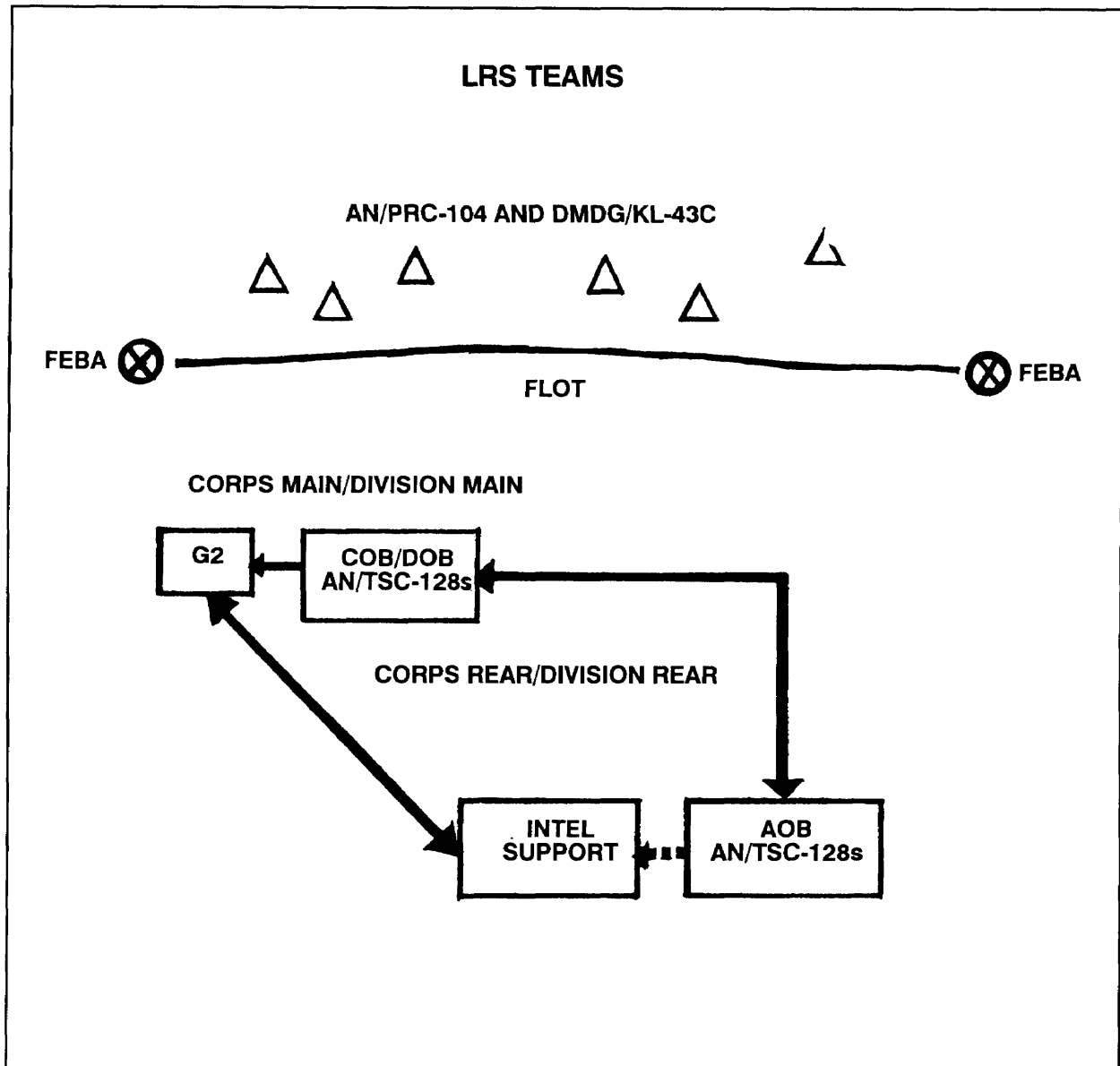

Figure 2-7. LRSU data flow.

## 2-11. BASE RADIO STATION OPERATIONS

The primary mission of the base radio station is to receive and transmit messages between the operations base and employed teams. Each base radio station monitors all deployed team frequencies. The AN/TSC-128 is the basic system for the base radio station. Two AN/TSC-128s makeup one base radio station. Each AN/TSC-128 maintains communication to three LRSU teams. To accomplish this, the AN/TSC-128 is equipped with three HF radios (AN/GRC-213) to receive communication from deployed team and one HF radio (AN/GRC-193) to transmit to the teams and other stations. In addition, the AN/TSC-128 is equipped with four DMDGs or KL-43Cs, one UGC-74 teletype terminal, one VRC-series radio (or mobile radiotelephone for mobile subscriber equipment), and a UGC-7 facsimile machine.

a. The LRSC establishes two base radio stations at the COB and two at the alternate sites. The LRSD establishes a base radio station at the DOB and at an alternate site. The base radio stations at the COB or DOB are the primary link to teams in the field. The base radio stations at the AOB serve as backup. They are prepared to receive messages the COB or DOB cannot, take over the mission if the COB or DOB displaces, and take over the mission if the COB or DOB is destroyed.

b. The success of HF communication often depends on the type of antenna erected. The best antenna is resonant to the transmitter frequency. The antenna cut to the proper length adds gain to the antenna and increases the success of communication. The base radio station will have the terrain, security, and time to construct matching full-wave and half-wave antennas. Employed LRSU teams often compromise in their antenna selection, depending on METT-T. The base radio station takes all actions necessary to ensure communication. The base radio stations at the AOB build different types of antennas than the COB or DOB. This adds flexibility and provides different paths for transmission. (See Appendix D for more information.)

c. Constant communication between the COB or DOB and AOB is necessary. The AOB must be ready to assume the mission of the COB or DOB and must track the battle. The primary communication link between the COB or DOB and the AOB is the corps or division tactical switching system. As a backup, the base radio stations at the COB or DOB and the AOB maintain communication with tactical FM radios using the published frequencies in the SOI and with their HF radios using the HF guard frequency. Message traffic between the two stations is sent by data burst, facsimile, teletype, or secure voice.

d. COMSEC is management intensive for LRSU operations. Each team has individual cryptographic for communicating with the base radio station. In addition, local nets have their own cryptographic requirements. The LRSC or LRSD commander ensures the unit's COMSEC custodian keeps the proper material in the correct amount on hand, both for training and contingency missions. Possible COMSEC keys needed for LRSU operations are —

- Corps or division intelligence net.
- MI brigade or battalion net.
- Internal company or detachment net.
- One key per team (KL-43C or one time pad) with one copy of this key for each base radio station monitoring the team.
- Digital secure voice terminal key for mobile subscriber equipment network.

e. In addition to cryptographic, LRSU COMSEC requires intensive frequency management. The nature of HF communication and the OPSEC requirements for LRSU teams places a high demand on multiple HF allocations. HF reliability changes with the time of day, time of year, position of the transmitters on the earth's surface, and the type of equipment used. Good OPSEC demands different frequencies for each team employed and a separate frequency for the HF guard. For an LRSC, that can mean as many as 19 frequencies at a given time of day and as many as 7 for the LRSD. The LRSU commander coordinates with the corps or division signal officer to ensure the LRSU is allocated the frequencies it needs for the mission.

f. Each base radio station maintains a log of all messages. The team chief ensures all messages for committed teams originate from the operations section. When a team message is received, the operator logs in the message, then forwards it to the operations section for decryption. If there is an outgoing message for a team, the operation section encrypts it. The operator then transmits it to the team during the team's next scheduled communication time.

## **2-12. SURVEILLANCE TEAM COMMUNICATIONS**

HF radio is the surveillance team's primary means of communication with the base radio station. Data-burst equipment is used to shorten transmission times. Encryption systems are used to preclude enemy interception. In addition to HF radio, teams use tactical satellite assets when available.

a. The RATELO selects the communication site, with the team leader's approval, using METT-T. Communication site considerations are security, cover and concealment, space to erect an antenna, and an escape route.

b. Teams transmit and receive routine messages during the scheduled communication times. For messages requiring transmission outside the time schedule, the team first tries to transmit on the designated team frequency. If communication cannot be achieved on the team frequency, the team then transmits on the HF guard frequency.

c. Internal communication within the team is maintained using secure FM and visual and sound signals. (See Appendix E.) Leaders ensure proper OPSEC and COMSEC precautions are followed.

### 2-13. ELECTRONIC WARFARE

Electronic warfare is a military action used to prevent the enemy's use of the electromagnetic spectrum, while retaining friendly use of the spectrum. This is accomplished through both offensive and defensive measures.

a. Offensive electronic warfare operations include the use of electronic warfare support measures and electronic countermeasures.

(1) Electronic warfare support measures are actions taken to search for, intercept, locate, record, and analyze radiated electromagnetic energy.

(2) Electronic countermeasures are actions taken to prevent or reduce effective use of the electromagnetic spectrum by the enemy.

b. Defensive electronic warfare operations include electronic counter-countermeasures (ECCM). ECCM are actions taken to ensure effective use of the electromagnetic spectrum despite electronic warfare activity by the enemy.

c. To protect themselves from enemy electronic warfare activity, LRSUs apply ECCM. ECCM have two categories: **preventive** and **remedial**.

(1) *Preventive measures* are those actions taken to prevent or lessen the effectiveness of enemy electronic warfare. They include emission security, transmission security, cryptography security, and physical security.

(a) Emission security includes —

- Turning radios and other emitters on only when they are to be used.
- Using brevity lists.
- Masking antenna locations.
- Using directional antennas.
- Using the lowest possible output power.

(b) Transmission security includes —

- Using voice communication only when essential.
- Developing and using brevity lists.
- Minimizing transmission time.
- Planning messages.
- Always using brevity lists when sending essential elements of friendly information.
- Encrypting messages.

(c) Cryptography security includes using authorized codes and key lists. Only National Security Agency approved codes are authorized for encoding and decoding US Army message traffic. The same is true of mechanical cryptography systems.

(d) Physical security of all cryptography and equipment includes a comprehensive and workable plan for the destruction of material and equipment. It also includes the SOPs that identify to all team members where material and equipment are kept by the RATELO. Priority for the destruction of material and equipment is as follows:

- All superseded cryptography keys.
- All current cryptography keys.
- Zero KL-43C.
- All future cryptography keys.
- Communications log.
- KL-43C.
- Radios.
- Brevity list.

(2) *Remedial measures* apply to interference and jamming. When interference is heard and jamming is suspected, the following actions should be taken:

(a) Remain calm and continue to operate as if nothing is happening.

(b) Do not allow the enemy to know his jamming is successful or detected.

(c) Go to a higher power on the radio.

(d) Reorient the antenna to the receiving station.

(e) Report the jamming using the meaconing, intrusion, jamming, and interference report format in the SOI supplemental instructions. Do not file the report on the same net that is being jammed.

(f) Use an alternate frequency if communication cannot be established or maintained.

### **Section III. MISSION DEVELOPMENT**

Long-range surveillance missions are specific, require detailed planning, and support the collection plan of the supported corps or division. All LRSU missions are carefully planned and coordinated to prevent duplication of effort, conflicting requirements, and the possibility of overlapping or intermingling with other friendly forces in the area. Corps ensure LRSC missions do not conflict with subordinate division LRSDs, between divisions, or with the echelons above corp special operations forces. Divisions ensure LRSD missions do not conflict with friendly forces working in their area.

#### **2-14. PLANNING**

The LRSU commander or his representative (liaison officer, operations officer, operations NCO, or platoon leader) assists the intelligence and operations sections of the division or corps headquarters in the initial planning for LRS missions. Methods of operations while deployed, communication procedures, reporting, and other standard practices are in the LRSU SOP. An LRS team normally requires 24 to 48 hours planning time to execute a mission. The recommended planning time is often not available. The following minimum-essential information is provided for hasty mission execution:

- Mission statement to include area or object to be kept under surveillance, eyes-on-target time, and anticipated length of mission.
- PIR, IR, and associated SIR.
- Enemy situation in the target area.
- Corps or division commander's intent for intelligence (can be stated by the G2 or G3).
- Method of insertion with abort criteria. Coordination time and place are included, if applicable.
- Fire support plan to include assets available.

- Exfiltration plan.
- Communication plan (provided by the LRSU headquarters).
- Linkup, if applicable.

a. **Special Considerations.** METT-T guides the planning for LRS operations. The reverse planning sequence is used during planning. Among the many planning considerations, the following are particular to LRS operations.

(1) *Mission.* This includes the type of mission (surveillance, reconnaissance, target acquisition, damage assessment), the anticipated length of the mission, and the time the information is required to be collected.

(2) *Selection of tentative hide site.* The position selected must offer good observation, concealment, communication requirements, and an adequate area for team rest, maintenance, and personal hygiene. When ground or air reconnaissance is impossible, the position is selected by map and photograph reconnaissance and line-of-sight survey data. The position should provide observation of the objective, avoid detection, and provide suitable signal communication. Closeness to and access from the infiltration and exfiltration sites are also considered. At a minimum, a tentative primary site and an alternate site are always selected. (See Appendix E.)

(3) *Selection of tentative surveillance site.* Performing all mission requirements from the hide site is not always possible or desirable. Under those circumstances, a separate surveillance site(s) is chosen. The general location is determined during planning and pinpointed after the team is on the ground. The surveillance site is normally close to the hide site with an accessible route over terrain that conceals the connecting route. A primary site and an alternate site are always selected. In some environments, primary and alternate sites are selected for both day and limited visibility conditions.

(4) *Selection of tentative communication site.* Conducting communication from the hide site is not always possible or desirable. Under those circumstances, a separate communication site is chosen. The general location is determined during planning and pinpointed after the team is on the ground. The communication site should be near the hide site with an accessible route over terrain that conceals the connecting route. Additionally, when selecting the communication site, the LRS team should consider all aspects of ECCM and site selection criteria discussed in Appendix D.

(5) *Selection of tentative infiltration site.* The location of the infiltration site is considered after the selection of hide, surveillance, and communication sites. Infiltration site selection is based on the infiltration method, the distance to the hide site, enemy and local populace activity in the area,

availability of a concealed route to the hide site, and any impassable obstacles on the route.

(6) *Selection of an infiltration method.* The method and route of infiltration into the area is considered after an infiltration site is selected. Frequently, several suitable insertion methods are available. METT-T is used to determine the best method. Specific considerations include mission, enemy situation, terrain and weather, resources available depth of penetration, training of the team, team survival, and simplicity. (See Chapter 6.)

b. **Detailed Planning.** G2, G3, and LRSU operations personnel prepare the detailed mission folder according to guidance from the commander and the controlling headquarters. Selected team leaders, a representative from the units providing transportation, SEAD, and fire support are briefed early in the planning phase. They should also participate in the detailed planning that follows. During briefings, team leaders are furnished minimal information about friendly units to maintain OPSEC. Essential details of the LRS team plan normally include the following.

(1) An overview of the enemy and friendly situation, followed by specific information in the immediate area of the operations. How the situation, light, and weather data will affect team operations are critical.

(2) Clearly stated PIR and associated SIR, and IR and associated SIR.

(3) Mission statement.

(4) Commander's intent for the mission.

(5) The area to be kept under surveillance and possible places from which this can be done.

(a) General team positions are determined as far as possible in advance of employment of the teams. Positions are selected based on the study of terrain, road and rail nets, enemy situation, delivery means available, operations plans of controlling headquarters, and the LRSU commander's guidance.

(b) When possible, positions are reconnoitered before occupation. Specific positions are selected to cover the desired surveillance objective, and communication checks are made. Physical or air reconnaissance is desirable. The team leader selects and reports the specific position location when he gets to the area.

(c) Actions taken if enemy contact is made in the objective area; at the hide, surveillance, and communication sites are covered. Criteria for using weapons with reduced signatures is also covered.

(6) The air mission briefing, which discusses the number and type of aircraft needed, flight routes, air cover or fire support required, primary and alternate insertion points, false insertion or extraction points, and frequency



and call signs. For extraction, the same information is covered including pickup zone locations and markings, and the date and time for the aircraft to be at the pickup zone. Contingency plans are covered including actions in the case of a downed aircraft, point of no return criteria, and actions in the case of enemy fire on the landing or pickup zone.

(7) Movement routes, formations, and actions at danger areas and halts from the infiltration site to the objective area.

(8) The fire support plan, which includes plans for indirect and aerial delivered fires. Specific plans include —

- Planned fires on movement routes and on and around the objective area.
- Planned fires on known, suspected, templated, and anticipated enemy positions.
- Use of smoke to mask movement.
- Use of illumination to help observation.
- Fires to aid navigation.
- Suppressive fires as part of an SEAD.
- Restrictive-fire areas or no-fire areas.
- Use of laser designators or beacons.

(9) The timing for execution of major events in the operation.

(10) Movement routes, formations, rally points, and actions at danger areas and halts from the objective area to the exfiltration site.

(11) Plans for evasion and escape to include planned evasion corridor, designated areas for recovery, and actions at recovery areas. (See Appendix F.)

(12) Plans for the use of guides, technical specialists, or special equipment.

(13) Coordination measures with friendly forces for the passage of lines or linkup.

(14) Plans for treatment of sick or wounded team members in the operational area or evacuation from the operational area.

(15) Actions to take in the case of captured enemy personnel and equipment.

(16) The communication plan, which includes frequencies, logs, reporting schedule, emergency reporting procedures, and alternate communication plans. The plan also includes actions if communication cannot be established.

(17) Plans for logistical support to include emergency resupply and use of caches.

- (18) Uniform and equipment for the team.
- (19) Abort criteria for each phase of the mission.

## 2-15. COORDINATION

Throughout planning, coordination is made with the following elements at the TOC of the controlling headquarters.

a. **Intelligence Element.** The detailed patrol plan is given to the G2 element. An update on the enemy situation, terrain, and weather forecasts must be added to the mission folder. A final check is made of the LRSU plans and the plans of other information-gathering agencies to make sure all collection elements of the unit's intelligence plan are coordinated. Coordination is made with other units and staff elements.

b. **Operations Element.** The patrol plan is also given to the G3 element. The latest information is obtained on the friendly situation. For security reasons, only essential information is provided to the team. The G3 element is responsible for initial coordination with the unit providing transportation for the LRS team. The G3 element coordinates as necessary with the division air management element, Air Force liaison, and naval gunfire liaison.

c. **Division or Corps Fire Support Element.** The location of the team is coordinated with all fire support elements to ensure personnel safety. Constant coordination ensures the team's safety during employment of conventional nuclear or chemical weapons. Procedures are set up for processing LRS team calls for fire and informing teams of planned fires and passive protection measures to be adopted. In addition, requirements for target damage assessment and reporting procedures are coordinated, and a fire support plan is completed for each LRS team. Team locations must be coordinated with division fire support coordinator so that the location can be designated as no-fire areas or restrictive-fire areas. This information is disseminated to units on a need-to-know basis.

d. **NBC Element.** The NBC element is given the location of all committed teams, and plans are coordinated for monitoring requirements in the area of the team's operation. Information on contaminated areas is distributed as necessary.

## 2-16. WARNING ORDER

After the unit has been alerted for a mission, the operations section of the LRSC, or the LRSD commander, issues a warning order (mission alert notification) to one of the platoon leaders (LRSC) or the team leader (LRSD), and finalizes the mission folder. The warning order is based on the

commander's guidance. The surveillance platoon leader in the LRSC designates a team for the mission and issues a warning order to the team. In the LRSD, the commander selects the team. Upon receipt of the OPORD and after issuing a warning order, the team leader coordinates the following requirements with the platoon leader or the platoon sergeant (LRSC), or the detachment commander (LRSD), as applicable:

- Infiltration method.
- Exfiltration method.
- Transportation.
- Special equipment.
- Passage of lines.
- Linkup procedures.
- Communication procedures and equipment checks.
- Checkpoints, phase lines, and code words.
- Fire support and restrictive-fire areas.
- Evasion and escape plan.
- Ammunition and pyrotechnics.

#### **Section IV. OPERATIONAL SECURITY**

Avoiding detection by the enemy and the populace is a prime requisite for the success of LRS operations. LRSU subelements and supporting elements must rely extensively on OPSEC measures.

##### **2-17. TACTICAL AND ADMINISTRATIVE MEASURES**

Control of information pertaining to past, present, and future LRS missions is important. Periodic security orientations and inspections, including communication elements and procedures, are conducted regularly to make sure that OPSEC requirements are understood and followed. Tactical security and deception measures necessary to teams and their support elements include the following:

- While en route to the area of operations, they use false landings, feints, and circular or winding routes.
- During insertion, they spend only minimum time on the LZ or dismount point, and they remove or obscure any tell-tale signs.

- In the surveillance area, they use cover, concealment, and camouflage; control of movement, stealth; light, noise, and odor discipline; and litter removal or burial.
- During aerial emergency resupply, they use night air drops and drops on dummy positions.
- During extraction, they make careful observation of the PZ or designated recovery area, rapid entry of the helicopter (ground or water vehicle), and quick assembly, boarding, and departure of the helicopter (ground or water vehicle).

## **2-18. ELECTRONIC MEASURES**

Radio intercept and radio direction finding are the primary methods of gathering intelligence through electronic means. Radio intercept entails monitoring and understanding message content. Radio direction finding locates transmitting stations by tracking their signals.

a. Many potential adversaries have an extensive intercept capability for electronic transmissions. They can intercept transmissions within the following distances from the forward edge of the battle area:

- Artillery ground radar—about 25 kilometers.
- VHF—about 40 kilometers.
- HF groundwaves—about 80 kilometers.
- HF skywave—unlimited.

NOTE: These ranges are greatly extended when airborne intercept is employed.

b. Ground-based and airborne intercept equipment available throughout the world is technically sophisticated, rugged, and easy to maintain. Enemy forces must be considered to have a modern intercept capability.

c. Enemy direction-finding capability is comparable to their intercept capability. Various types of mobile, directional antenna systems can be used in a radio direction-finding role. Forward-area mobile elements include a VHF tactical radio direction finder with an Adcock antenna, as well as the pole dish radar direction finder. Tactical FM radios operating on low power can be detected by radio direction-finding units for more than 10 kilometers and high-power signals can be detected at distances up to 40 kilometers. Radio direction finding is usually accurate within plus or minus 3.5 degrees.

d. Direction finding is used —

- To provide approximate locations of electronic emitters.
- To provide locations that when applied with signal intelligence, terrain analysis, or other means, can be refined to a target area of sufficient accuracy for artillery fires.
- To develop a picture of the battlefield that reveals the disposition and possible intent of enemy units.
- To provide adequate locations for firing on most radars and jammers.

e. Figure 2-8 illustrates enemy ground-based electronic intercept and direction-finding capabilities. Once begun, the targeting sequence can continue even if friendly communication ceases. The location of radios transmitting in excess of 20 to 25 seconds will be plotted within two to three minutes of the intercept. LRS team members must be aware of this and must adhere to approved operating procedures.

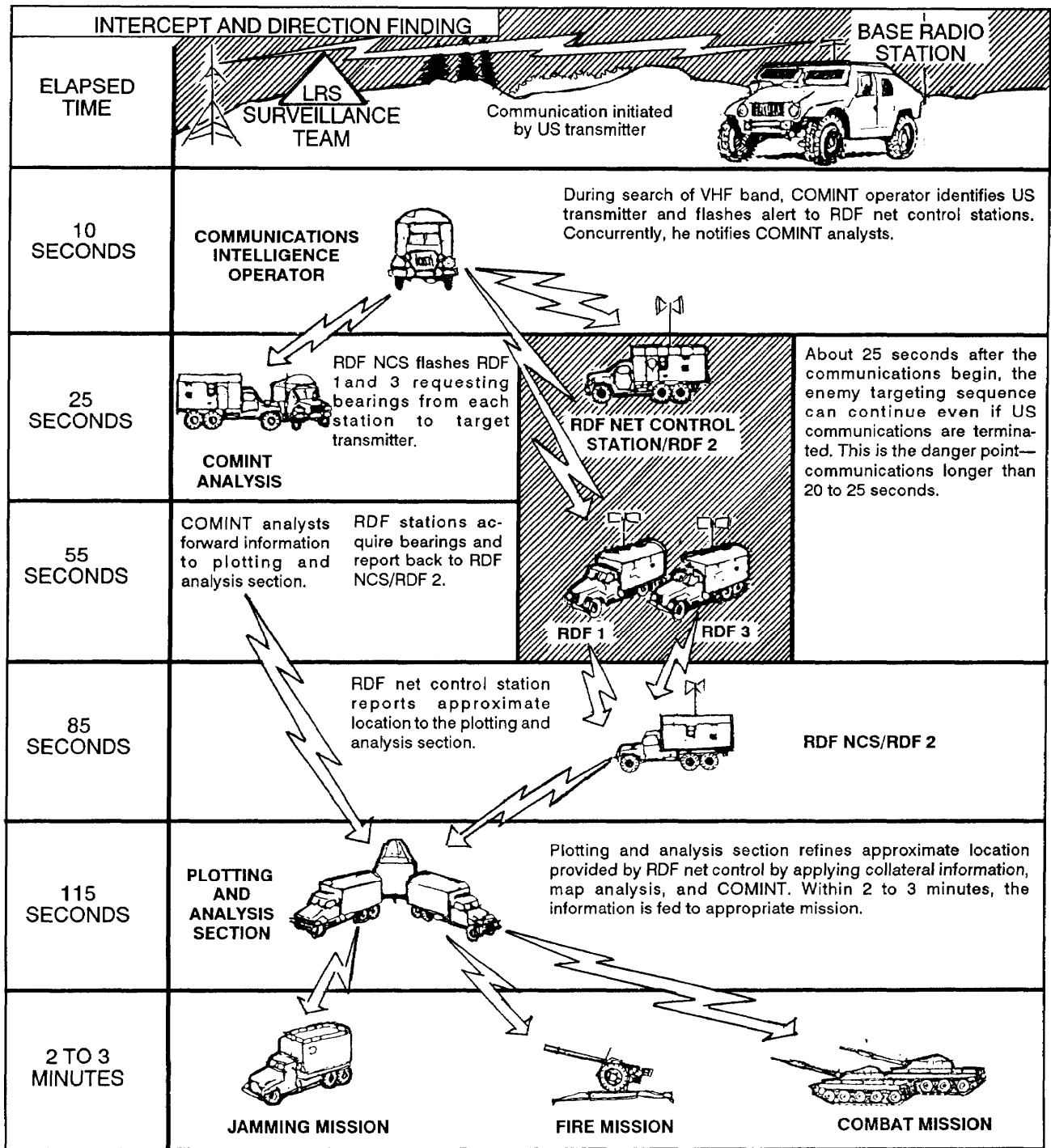

Figure 2-8. Enemy intercept and direction finding.

## CHAPTER 3

**OPERATIONS**

*Operations conducted by LRS teams provide critical information to the corps and division commanders. LRS teams accomplish this by collecting the commanders' PIR. Without answers to PIR, the commander cannot make an informed decision as to how to fight the battle. By contrast, the well-informed commander can develop feasible courses of action and make logical decisions on how to fight the battle. The success of LRS operations depends on thorough planning and acquiring PIR and reporting it in a timely manner while at the same time avoiding detection. LRS team operations are divided into five distinct phases—planning infiltration, execution, exfiltration, and recovery. However, an LRS element may be involved in more than one phase at the same time, while controlling or supporting deployed teams.*

**Section I. PLANNING PHASE**

The planning phase covers the G2 conception of the mission to the final inspection of the LRS team. Specific actions that normally occur in this phase are —

- Mission folder preparation. (See Appendix G, paragraph G-2.)
- G-staff coordination.
- Warning order.
- Movement to the planning area.
- Operations order from the LRSU headquarters with mission folder.
- Mission analysis by the LRS team leader.
- Briefback by the LRS team leader.
- Planning, operation order, rehearsals, inspections, and coordination by the LRS team.
- Briefback by the LRS team.
- Final inspection.

**3-1. CONTINGENCY PLANS**

Each LRS operation requires specific contingency plans for evasion and escape, inflight abort, downed aircraft, emergency resupply, emergency extraction, and lost communications.

### 3-2. CONTROL MEASURES

Select control measures assist in controlling the team during a mission. These include —

- Time of departure and return.
- Points of departure and reentry.
- Checkpoints.
- Routes.
- Forward line of own troops.
- Phase lines.
- Restrictive-fire areas.
- Forward edge of the battle area.

### 3-3. PLANNING AREA ACTIVITIES

Detailed planning ensures mission success and team survival. On receipt of the warning order, the team begins an intensive preparatory phase at the operations base. The team receives its initial mission briefing there. The planning area is a secure place in which teams that have been committed to operations do their planning and preparing.

a. The team leader and the assistant team leader (and preferably the entire team) receive the mission briefing from the commander or the operations section. The team leader receives the mission folder at the beginning of the briefing to ensure he understands all facets of the operation. New and relevant data can be added to the original data during preparation. (See Appendix G for mission folder information and Appendix H for orders format.) Mission folders normally include —

- The operation order.
- Maps and overlays.
- An intelligence update.
- The intelligence indicators.
- Terrain, weather, and visibility data.
- LZ or DZ photographs and data.
- Photographs of the operations area.
- The planning area time schedule.
- Blank manifest cards (DA Form 1306, AF Form 96).
- Overlay paper.



- Observer report pads.
- One-time pads and other cryptographic material.

b. Following the briefing, the surveillance team leader begins his planning. He may conduct a visual reconnaissance of the area of operation. The assistant team leader supervises the initial equipment and personnel preparation, while the team leader is reconnoitering. The TOC personnel are available for coordination throughout the planning phase.

c. The team leader uses specific steps in planning, preparing, and executing LRS missions. These procedures are comprehensive, yet flexible enough to adapt to any situation. The success of the plan depends on the team leader using the OPORD as his primary planning tool. The briefback is a form of rehearsal and should not be the focus of the planning effort. The following are specific planning steps.

(1) Receive and study the mission.

- Conduct a mission analysis. The team leader identifies the specified, implied, and essential tasks necessary to execute the mission. The team leader also identifies any limitations the team has to contend with. This analysis results in a restated mission containing the essential task(s).
- Study strengths, locations, dispositions, and capabilities of both friendly and enemy forces that may affect the team's mission.

(2) Plan use of time.

- Prepare a written schedule for required actions.
- Use the reverse planning technique.

(3) Study the terrain and the situation. The team leader uses a map and aerial photos to analyze cover, concealment, observation, obstacles, key terrain features, avenues of approach, and withdrawal routes. (See Appendix C for information on operational environments.)

(4) Assign tasks to the team members.

(5) Select and request equipment (routine and special).

(6) Continue coordination.

(7) Issue a warning order.

(8) Develop a tentative plan based on analysis of METT-T.

(9) Conduct a briefback with the commander.

(10) Reconnoiter the area. If visual reconnaissance is not possible, the team leader studies aerial reconnaissance photos to confirm, clarify, and supplement information from maps and other sources.

(11) Complete detailed planning.

(12) Brief the operation.

- Use the standard OPORD sequence, shortened and simplified to fit the team situation.
- Use visual aids (terrain models, chalkboards, and sand tables) if available. If not, improvise to ensure understanding.

(13) Supervise and inspect the soldiers. The team leader supervises his soldiers throughout the preparation to ensure timely completion of required tasks. Then he conducts inspections to make sure —

- Only equipment required for the mission is taken.
- All equipment is functional, complete, secured, and evenly distributed.
- All members are camouflaged, understand the mission, and are mentally prepared.

(14) Check the communication equipment. The team leader also checks all of the communication equipment with a distant base radio station.

(15) Rehearse the mission. The team leader conducts rehearsals as soon as possible after briefing the operation order and inspecting personnel and equipment. The full uniform and equipment required by the mission will be worn or carried during rehearsal. The more complex the procedures, the greater the need for detailed rehearsal. Rehearsals are conducted on terrain and under conditions close to those to be encountered in the operation. They should entail as many contingencies as can be anticipated. They should use simulated casualties among key personnel, with subsequent assumption of duties by other team members. Throughout the rehearsal, team members are asked mission-specific questions. Sand table briefings, map study, and photograph examinations should complement rehearsals. Standard rehearsals should include the following:

- Off-loading and assembly procedures at points of insertion.
- Movement formations.
- Lost-man drill.
- Security halt procedures.

- Actions at possible danger areas.
- Actions in the objective area (entering; maintenance; and sterilization of the hide, surveillance, and communication sites). At a minimum, during hasty planning, rehearsals of actions in the objective area are always completed.
- Reaction drill for aircraft flyover (friendly or enemy).
- Counter-tracking techniques.
- Actions on enemy contact (chance, near and far ambush, sniper, air attack, indirect fire, flares).
- Loading procedures at the extraction site.
- Special actions (as required) and use of new or unfamiliar equipment.
- Procedures for emplacement and recovery of a cache.
- Actions at designated recovery areas during evasion and escape.

(16) Hold a briefback. When mission planning is complete, the team gives a briefback of the entire mission to the commander or the commander's designated representative or operations section. The briefback may be shortened as needed for hasty planning or as the commander deems appropriate based on his knowledge of team experience, and who will receive the briefback. (See Appendix I for a briefback format.) The briefback enables —

- The commander or operations section to make sure the team understands and is prepared for the mission.
- The commander or operations section to suggest changes in the plan, if necessary.
- Team members to ask final questions.
- The team to conduct a final rehearsal of the plan.

(17) Conduct a final inspection. The team leader conducts a final inspection as the last step before the team leaves the planning area. He inspects personnel, personal equipment, and mission equipment with special emphasis on items that were noted for correction during the initial inspection and rehearsals. The team leader questions team members again to reinforce critical facets of the mission.

(18) Receive intelligence updates as available.

## Section II. INFILTRATION PHASE

The infiltration phase covers all actions from staging for departure to arrival at the infiltration site. The following are specific actions that normally occur in this phase:

- Staging.
- Movement by air, water, vehicle, foot, stay-behind, or any combination of these.
- Assembly.

### 3-4. MOVEMENT TO THE DEPARTURE AREA

The departure area is where the transporting unit will pickup the team for delivery to the insertion point; or if infiltrating on foot, to the passage point near the forward edge of the battle area. Teams can be infiltrated or exfiltrated by land, sea, or air, or a combination thereof. The most common method is by air insertion—more specifically, by helicopter. Setting patterns that the enemy could exploit must be avoided.

### 3-5. STAY-BEHIND

This method is used during retrograde operations or withdrawal of covering forces in defensive operations. When possible, the hide site and the surveillance site should be one site to minimize movement.

a. The **advantages** of stay-behind operations are not having to infiltrate an LRS team into the area of operations, and the ability to pre-position mission-essential equipment and supplies.

b. The **disadvantages** of this employment are the disruption of C2 associated with the passing advance of enemy forces and the inability to pinpoint locations of interest in the advancing enemy lines of communication.

### 3-6. INFILTRATION

Infiltration is the first critical phase of an LRS operation, because the team often has to pass through heavily defended terrain where sophisticated detection devices may be used. The selected method of infiltration depends on the mission, enemy situation, resources available, weather and terrain, depth of penetration, training of the team, team survival, and simplicity. The best method is the one that is least likely to be detected. Security and secrecy of movement must not be sacrificed for convenience. The team must maintain the advantage of operating by stealth regardless of the infiltration method. Infiltration requires the support of the corps or division staff to include the G2, G3, fire support officer, air defense artillery officer, and air

liaison officer. Certain fundamentals apply to every infiltration. (See Chapter 6 for more information on infiltration.)

a. **Intelligence.** Operational plans are based on timely and accurate intelligence. The headquarters directing the operation provides the most up-to-date and specific details on the area of operations and infiltration routes from all sources. These include friendly tactical units, other services, and special agents. Special emphasis is placed on efforts to obtain information on the enemy's capability to detect forces infiltrating by air, water, or land. The location and capabilities of air defense radar and weapons systems are critical.

b. **Deception.** Plans are made to deny the enemy knowledge of the team's infiltration or to deceive him as to the location or intent of the operation. Feints, false insertions, and other cover operations (such as airstrikes, ground attacks, and air assault operations), as well as the use of multiple routes and means of infiltration, electronic countermeasures, and false transmissions contribute to LRSU deception plans. Selection of unexpected means of infiltration, times, places, and routes, coupled with speed and mobility will help deceive the enemy. Planning may also include using diversionary fires to direct the enemy's attention away from the team. Specific techniques that may be used include the following:

- Multiple airdrops, water landings, or both to preclude detection of the team.
- Dispersion of infiltration craft (air or water) if more than one, both in time and location.
- Landing a force in an area closer to other potential targets than to the actual targets to deceive the enemy.
- Leaks of false information to deceive the enemy.
- False landings or insertions.
- Diversionary actions, such as airstrikes in other areas, to distract the enemy from the intended target area.
- Increased reconnaissance flights over false areas to further confuse the enemy.

c. **Speed and Mobility.** Speed is essential to limit the amount of time required to insert the team. Individual loads must be tailored to enhance speed and mobility, and balanced with the mission-related items necessary to achieve mission success. If possible, the team should carry only what they need immediately and cache the rest.

d. **Stealth.** Movement techniques, time of insertion, routes, and the distance from the insertion area to the patrol base are places where stealth must be emphasized to avoid detection or interception by the enemy.

e. **Suppression.** Every effort is made to suppress enemy detection devices, weapons systems, and command and control facilities by electronic jamming or by suppressive fires. This detracts from the enemy's capability to discover the team during infiltration. Deception techniques contribute to suppression activities.

f. **Security.** Security measures to prevent compromise of the impending operation are emphasized during preparation. This includes security of rehearsal and training sites, or open use and procurement of special equipment (to include maps of the objective area). Some measures that may be used to assist in maintaining security are —

- Restrict access to the planning area.
- Brief details of the operation to the team in the planning area.
- Limit knowledge of planned operations to those with a need to know. This may include other LRS teams operating in the same area.

g. **Reconnaissance, Surveillance, and Target Acquisition Considerations.** Reconnaissance, surveillance, and target acquisition equipment is used to detect and avoid enemy forces and their detection devices. Passive night vision devices are used to achieve rapid assembly and reorganization. Teams may also use these devices to help control and speed up movement, and traverse seemingly impassable terrain.

h. **Rehearsals.** Rehearsals must parallel, as nearly as possible, actual conditions of infiltration or exfiltration. Rehearsals are conducted on terrain similar to that in the area of operations.

i. **Sand Tables.** In the planning phase, sand tables are extremely effective for orienting personnel on unfamiliar drop zones and surrounding terrain. The use of sand tables and terrain models during the issuance of prejump orders and briefings enhances orderly and rapid assembly on the ground.

### 3-7. AIR INSERTION

Air insertion is the fastest way to infiltrate. Surveillance teams and equipment may be delivered by parachute (static-line or free-fall technique), fixed-wing (airlanding), or helicopter (airlanding, rappelling, FRIES, ladder, or parachuting).

a. **Special Factors.** Several factors must be considered when planning an air insertion.

(1) Suppression of enemy air defense may be necessary along the infiltration corridor. Suppression of enemy capabilities that may interfere with insertion of the team is essential. This is done by a variety of sophisticated countermeasures applied against enemy equipment and by strikes against known or suspected enemy positions. Assistance may be provided by artillery, aircraft, or naval gunfire.

(2) Two primary danger areas are the forward area where the enemy uses many of his most sophisticated weapons systems and air defenses, and critical target areas behind the enemy lines (troop concentrations, military installations, and control centers).

(3) Since most of the enemy's detection devices and air defense weapons may be at or near the point of entry, fire support, smoke screens (even at night), and suppressive measures may be critical. Special equipment may be required to counter the enemy's reconnaissance and surveillance effort whether moving by air, water, or land.

(4) If this area is within artillery or naval gunfire range, fires should be planned on known and suspected enemy antiaircraft locations and on prominent landforms along the route. Once beyond this area (and perhaps for most of the route), teams will be beyond the range of conventional artillery, and must depend on air (and perhaps naval) assets for fire support.

(5) Since teams depend on the transporting unit during this phase, coordinating all aspects of the air insertion with the transporting units is essential. To lower the chances of detection, teams make the best use of reduced visibility, tactical cover, and deception. Drop zones and landing zones should be behind tree lines, in small forest clearings, or on other inconspicuous terrain.

(6) All flights over enemy territory should be routed over unoccupied areas. Flights are planned to complement cover and deception phases and to avoid enemy air defenses.

(7) In-flight emergencies must be considered, particularly during deep penetrations. The team must know the route and the checkpoints along it. Simple ground assembly plans for contingencies are established before boarding. In an emergency, the platoon leader (LRSC) or commander (LRSD) decides whether to continue or abort the mission. In the absence of the platoon leader or commander, the team leader makes the decision. The decision to continue or abort is based on METT-T factors, contingency plans, and the distance to the target as compared to the distance back to friendly territory. Contingency provisions should be made for air and water rescue as well.

b. **Special Airborne Assault Techniques.** In airborne insertions during limited visibility, major emphasis is placed on use of special delivery or navigational techniques.

(1) With the adverse weather aerial delivery system, personnel and equipment can be airdropped during bad weather, even during zero-visibility conditions. Insertions may be made (day or night) without a pre-positioned USAF combat control team or an Army assault team. The supporting air unit requires both extensive DZ intelligence and significant lead time. Thorough planning and coordination are essential between all forces involved in the operation.

(2) High-altitude, low-opening or high-altitude, high-opening jumps with high-performance parachutes let the jumpers maneuver to a specific point on the ground. During these operations, midair assembly procedures may be used.

(3) Low-altitude jumps with the rough-terrain suit allow jumpers to land in unimproved drop zones with little dispersion. After these operations, the LRS teams cache the equipment to prevent detection.

(4) Ram air static line parachutes allow jumpers to take advantage of the maneuverability and soft landing effects of ram air parachutes. Use of ram air parachutes allows jumpers to land in small drop zones, land softly, and quickly assemble.

c. **Assembly.** LRS teams must assemble and reorganize quickly and precisely, because they are so vulnerable to detection. Assembly areas and assembly plans are developed after careful consideration of METT-T factors, especially the location of the enemy, visibility, terrain, drop zone information, dispersion pattern, and cross-loading. The number of assembly areas depends on the location, the size of the available assembly areas, and the enemy's detection capability.

(1) Using the clock method, jumpers are briefed on the location of the assembly area(s) in relation to the direction of flight of the insertion aircraft with the direction of flight as 12 o'clock.

(2) Terrain association may be used as a backup method of designating assembly areas, but it has obvious disadvantages if the unit misses the drop zone, or if an in-flight change in mission dictates use of a new drop zone.

(3) During reduced visibility, a night vision plan is necessary during landing, assembly, and movement.

(4) During parachute insertion, team members must be ready for enemy engagement at all times, particularly on the drop zone. Immediate action drills are required to counter enemy contact on the drop zone.



(5) Cold weather airborne insertion is difficult but not impossible. Allocated times must be increased by at least 30 minutes for cold weather insertions.

d. **Planning.** The reverse planning process is critical.

(1) The ground tactical plan, as developed from the mission assessment, is the first planning area to be considered. All other planning begins from this point.

(2) The selection of PZs or LZs requires adequate planning and coordination for effective use of air assets. Site selections must be coordinated face-to-face between the supported LRS team and the aviation commander. The tactical situation is the key planning factor; others include the size of landing points, surface conditions, ground slopes, approach and departure directions, prevailing winds, obstacles, communications, aircraft command and control, PZ and LZ identification, and rehearsals.

(3) The air movement plan coordinates movement of the team into the zone of action in a sequence that supports the landing plan. Key considerations are flight routes, air movement tables, flight formation, in-flight abort plan, altitude, and air speed.

(4) The landing plan introduces the team into the area of operations at the proper time and place. Rehearsals cannot be overemphasized. The team rapidly assembles, reorganizes, and leaves the insertion site.

(5) Fire support, if available, may be artillery, naval gunfire, attack helicopters, or USAF tactical aircraft. The fire support plan supports all other plans. Supporting fires are thoroughly coordinated with the air mission commander.

(6) Other planning considerations are evasion and escape, actions at the last LZ, assembly plan, downed aircraft procedures, control measures, weather delays, deception plans, and OPSEC.

### 3-8. AMPHIBIOUS INFILTRATION

Water infiltration may be by surface swimming, small boat, surface craft, helocasting, or a combination thereof. Detailed information is needed to plan and execute a small-boat landing—the most difficult phase of a waterborne infiltration. Close coordination is required with naval support units.

a. **Planning Considerations.** Planning must be thorough. While on the transporting craft, plans must be made for all possible enemy action and weather. The transporting unit is given information only on a need-to-know basis. Even then, information that could compromise the operation may be withheld until the mission is underway. Initial planning includes the time schedule, embarkation point, drop site, landing site, and loading.

(1) *Time schedule.* The time schedule of all events from the beginning until the end of the operation is used as a planning guide. Accurate timing for each event is critical to the success of the operation.

(2) *Embarkation point.* The embarkation point is where the team boards the transporting craft.

(3) *Drop site.* The drop site is where the team leaves the primary craft and loads into smaller boats.

(4) *Landing site.* The landing site is where the team beaches its boat or lands directly from amphibious craft.

(5) *Loading.* Loads and lashings, with emphasis on waterproofing, are as established in the SOPs. Supervisors must make inspections.

b. **Beach Landing Site Selection.** The beach landing site must allow undetected approach. When possible, landing sites that cannot be approached from several different directions are avoided. The site should allow infiltration without enemy detection. If sand beaches are used, tracks and other signs that may compromise the mission are erased. Rural, isolated areas are preferred. The coastal area immediately behind the landing site should provide a concealed avenue of exit from the site. Other factors considered in each selection include —

- Enemy dispositions.
- Distance to the area of operations.
- Characteristics of landing and exit sites.
- Availability of cover and concealment.

c. **Tactical Deception.** In addition to the water approach route plan, plans are made to deny the enemy knowledge of the infiltration. This may include use of electronic countermeasures or diversionary fire support.

d. **Routes.** The route to the drop site is planned to deceive the enemy. If possible, the route is similar to a route used in some other type of naval operation (minelaying or sweeping, or patrolling). A major route change immediately after the team's debarkation could compromise the mission. Alternate routes must be planned.

e. **Navigation.** Ship-to-shore navigation (to the landing site) may be accomplished by dead reckoning, or the course may be maintained by compass navigation, reference to a shoreline silhouette, or radar.

f. **Actions at the Drop Site.** A primary and alternate drop site must be coordinated. The drop site should be at least 1,500 meters offshore to preclude compromise by noise during loading and launching. (Some operations may permit landing directly from the transporting craft on shore.) If

the enemy has a surface radar capability, the drop site may need to be several miles offshore, or the use of electronic countermeasures may be required.

g. **Actions at the Beach Landing Site.** To plan actions at the landing site, teams must consider the following:

- Actions during movement to the beach.
- Noise and light discipline.
- Navigational techniques and responsibilities.
- Actions on the beach.
- Plan for unloading boat(s) (SOP).
- Plan for disposal or camouflage of boat(s).

h. **Actions on the Beach.** Once on the beach, team members move to a covered and concealed position, conduct a brief listening halt, and then check the beach landing area for signs of enemy activity.

(1) Upon landing, designated personnel immediately move into covered and concealed security positions to defend the landing site.

(2) Boats may be deflated and buried or camouflaged near the landing site or away from it, depending on the enemy situation, the terrain, and the time available. If the boat(s) is to be disposed of or hidden near the landing site, a team member(s) is designated to dig holes or cut brush for camouflage. After the boat(s) is disposed of, designated members sweep the beach to erase tracks and drag marks.

i. **Insertion by Air From Ship.** Helicopters launched from a ship may extend the range of infiltrating teams. Helicopters may be vectored from ships to a predetermined landing zone. Once in the air, other aspects of landing and assembling are the same as discussed for air movement operations.

j. **Helocasting.** This form of insertion combines helicopters and small boats into the same operation. It is planned and conducted much the same as airmovement operations, except that the LZ is in the water. While the helicopters move at low levels (10 feet) and low speeds (10 knots), the teams launch the small boats and themselves into the water. Members then assemble, climb into the boats, and continue the mission.

k. **Contingency Planning.** The following contingencies are covered in the planning stage:

- Enemy contact en route.
- Enemy contact at the helocast site.
- Flares.
- Aerial attack.
- Indirect fire.

- Downed aircraft procedures (if applicable).
- Evasion and escape.
- High surf.
- Adverse weather.
- Separation.

1. **Rehearsals.** The team must rehearse all aspects of the amphibious infiltration to include boat launching, paddling, boat commands, capsize drills, beaching, and assembly.

### 3-9. LAND INFILTRATION

Land infiltration from a departure point to the area of operations sometimes may be the best (or only) way to infiltrate. Normally, this is when the enemy has air superiority or has established effective air defenses. The LRS teams can accomplish land infiltration over any type of terrain, in any climate—but thick forests, swamps, and broken or steep terrain probably offer the best chance of success.

a. **Planning Considerations.** Plans for overland movement enable the team to move to the area of operations with the least risk of detection.

(1) Concealed primary or alternate routes are selected based on detailed map reconnaissance and aerial photographs, ground reconnaissance, and data on the enemy situation from other sources.

(2) Obstacles, populated areas, silhouetting, enemy positions, main avenues of approach, and movement along heavily populated routes and trails must be avoided.

(3) The time of infiltration should be during reduced visibility and reduced alertness. The time is especially important during critical phases (crossing borders and passing through enemy troop concentrations or populated areas).

(4) Team members must know routes, rally points (and alternates), time schedules, danger areas, and enemy situation. These are critical to speed and stealth.

(5) The team should be provided centralized coordination to ensure that all members are acting in accordance with cover and deception plans. Infiltration by land is characterized by centralized planning and decentralized execution.

b. **Actions on Enemy Contact.** Once inside enemy territory, the team must be constantly alert to avoid detection while en route to the area of operations. (See Appendix J for battle drills.)

(1) If the team becomes aware of enemy presence, it tries to move away undetected.

(2) The team fights only when there is no alternative. Then it breaks contact as quickly as possible. Following enemy contact, the team leader decides whether to abort or continue the mission.

(3) Following enemy contact, the team may have to establish a temporary position for resupply, evacuation of wounded, or extraction.

c. **Stay-Behind Technique.** The team purposely allows itself to be passed by the enemy to perform a specific mission. Stay-behind operations sometimes require the concealment or cache of extensive supplies before the enemy bypasses. It may also require construction of a hide position. Other key considerations are —

- Camouflage.
- Noise and light discipline.
- Avoidance of enemy contact.
- Timing.
- Rough, inaccessible terrain.
- Medical evacuations.
- Communications.
- Linkup.
- Method of exfiltration.
- Evasion and escape.

d. **Actions at the Infiltration Site.** A detailed assembly plan must be developed. It is based on the infiltration method and the terrain at the infiltration site.

(1) An assembly area is selected that can be identified at night and that is near the infiltration site. The assembly area is used in case individuals become separated from the team during the infiltration. During parachute insertion, the assembly area is used as an assembly point.

(2) An initial rally point that can be identified at night is also designated. It is normally no closer than several hundred meters to the infiltration site. It is used for assembly in case the team is attacked while infiltrating or shortly after departing the infiltration site.

(3) When the infiltration is complete, the team leader accounts for all personnel, equipment, and supplies. Injuries are treated. If an incapacitating injury occurs, the team leader must decide, based on guidance, whether to continue the mission or request extraction. The casualty's equipment and supplies are redistributed. The most critical task is verifying the team's

location. This must be done at the infiltration site, or as soon as possible after departing the site, if there are no identifiable terrain features at the infiltration site.

(4) The site is sterilized, and nonessential equipment is cached or discarded. Burial away from the infiltration site is the preferred method. The cache site must be well camouflaged.

(5) The team leaves the infiltration site, then halts to listen for sounds of pursuit and to become familiar with the local sounds. It establishes a primary azimuth and immediately begins intelligence information collection activities and map update.

### Section III. EXECUTION PHASE

The execution phase covers actions from the movement from the infiltration site to arrival at the extraction site including all actions in the area of operations. Specific actions that normally occur in this phase are —

- Movement to the area of operations.
- Occupation of the hide site.
- Selection of the surveillance site.
- Actions in the area of operations.
- Reporting.
- Movement to the exfiltration site.

#### 3-10. MOVEMENT TO THE AREA OF OPERATIONS

Regardless of the means of infiltration, the selection of the route to the area of operations is critical. Enemy location, detection devices, and defensive capabilities; terrain; weather; and man-made obstacles must all be considered when selecting the primary and alternate routes. En route checkpoints are selected to keep track of the team. The teams can operate during reduced visibility by using night observation devices. The team's extensive training and land navigation skills allow them to rapidly traverse rugged terrain while avoiding detection. (See Appendix L for movement techniques.)



a. **Movement Formations.** Movement formations may vary during infiltration into the area of operations. The formation selection is based on visibility, terrain, and enemy disposition. Movement is keyed to the steps below. Movement should be covered in detail in the LRSU SOP.

- Team members maintain visual contact at a normal interval. (Interval can expand and contract based on terrain and visibility.)

- Members maintain noise and light discipline always.
- Each member observes the sector of responsibility assigned to him by the team leader.
- Team members react as their team leader does. (That is, when he gets down, they get down.)
- The team leader positions himself where he can best control the team.
- The team moves on routes that best conceal its movement from enemy observation, and cover its movement from direct enemy fire.
- The formation closes when moving through obstructions (darkness, smoke, heavy brush, narrow passes, and minefield).
- If the formation closes to single file, team members react as does the member to their immediate front.
- The formation opens when obstructions to movement and control lessen.

b. **Movement Security.** Each team member must be security conscious. The team must maintain continuous all-round security. During movement, each team member is responsible for an assigned security sector. The team's route must make the best use of cover and concealment. Security and listening halts are made as necessary. Camouflage of individuals and equipment must be enforced at all times.

c. **Arm-and-Hand Signals.** To reduce oral communication and to assist in control, the team leader establishes standard arm-and-hand signals. These signals should conform to those listed in FM 21-60 and the team SOP.

### **3-11. HIDE SITE AND SURVEILLANCE SITE OCCUPATION**

The tentative hide site and surveillance site(s) and routes are selected during the planning phase by map and aerial photograph reconnaissance. The team moves near to the tentative hide site and sets up an ORP. The team leader and one or two other members reconnoiter the site. They make sure the site is suitable and, if possible, the area to be observed can be seen from the site at ground level. The reconnaissance is made during limited visibility. The reconnaissance element then returns to the ORP and briefs the remainder of the team on the site occupation plan and their individual duties. The team then moves to the site and occupies it as prescribed.

They watch and listen for the enemy before starting construction. The process is duplicated for occupation of the surveillance site(s) if a separate site is to be used. (See Appendix E for more information on hide and surveillance sites.)

### **3-12. SITE SELECTION**

The selection of the hide site and surveillance site(s) is METT-T dependent. Considerations for site selection are —

- Can the team place the designated surveillance target(s) under continuous and effective observation and within the range of surveillance devices to be used?
- Will the surveillance site have to move if weather and light conditions change?
- Does the area provide concealment and entrance and exit routes?
- Are there dominant or unusual terrain features nearby?
- Is the area wet, is there adequate drainage, or is the area prone to flooding?
- Is the area a place the enemy would want to occupy?
- Is the site silhouetted against the skyline or a contrasting background?
- Are there roads or trails nearby?
- Are there other natural lines of movement nearby (gullies, draws, any terrain easy for foot movement)?
- Could the team be easily trapped in the site?
- Are there any obstacles to prevent vehicle movement nearby (roadside ditch, fence, wall, stream, river)?
- Are there any inhabited areas in the prevailing downwind area.
- Are there any suitable communication sites nearby?
- Is the site(s) in the normal line of vision of enemy personnel in the area?
- Is there a source of water in the area?

### **3-13. ACTIONS IN THE AREA OF OPERATIONS**

The primary method of employing surveillance teams is in a hide or surveillance site. However, the terrain, mission, and location of the site may dictate that the team leader establish a separate surveillance site(s) to effectively observe the area.



a. Noise, light, litter, and odor discipline must be maintained at all times. The team curbs movement (day and night) and talks only in whispers. Arm-and-hand signals are the normal mode of communication; however, if dictated by distance and vegetation, a messenger or FM communication may be used.

b. A minimum of two soldiers are required to conduct surveillance. One observes while the other records the information in the surveillance log. Because observer efficiency decreases rapidly after 30 minutes, the observer and the recorder switch duties about every 30 minutes. When using night vision devices, the observer's initial period of viewing is 10 minutes followed by a 15-minute rest period. After several periods of viewing, the period is extended to 15 to 20 minutes. Hide site personnel should be rotated every 24 hours.

c. During limited visibility, two to three (normally three) members may be required to set up a new surveillance site. The site is near the target area so that information may be collected through close-in observation and sound detection. The remainder of the team stays in the hide site. The surveillance site and the route to and from it are selected during good visibility. Members go in and out of the surveillance site during limited visibility. One member observes, one records, and one maintains security to the rear and flanks. Only passive night vision devices are used to help prevent detection.

d. The hide site may not be suitable for transmitting reports. When this is the case, a separate communication site is needed. A minimum of two personnel is required at the communication site; one to erect the antenna and send the message, and one to provide security. The communication site is occupied long enough to transmit the message and conceal any signs of the team's presence.

e. Hasty sites are used when the team plans to occupy for a short period (generally less than six hours). This most often occurs during reconnaissance or target-acquisition missions.

(1) The team makes the best use of natural cover and concealment. It uses man-made camouflage materials as required to improve concealment, keeping movement to a minimum.

(2) Generally, two or three members are positioned forward to observe the target area and record information. The hasty hide site is positioned far enough to the rear so it is out of the direct line of enemy observation. The distance normally depends on terrain and vegetation. It must be far enough away from the surveillance element so that if one of the two elements is discovered by an enemy force, the other element has enough stand-off to prevent them from being discovered also. The position will allow them to fire on the enemy, and enable one or both elements to break contact. The team members in the hasty hide site maintain rear and flank security.

Communication is normally conducted after the team moves away from the area.

### 3-14. REPORTS

The team follows the communication procedures as outlined in the SOP. The team members must make sure that communication is maintained throughout the mission by the use of directional antennas, masking, and burst transmissions.

a. The team reports information as directed by the operational schedule. Team members normally do not try to analyze the information but report what they see based on SIR. Then, G2 personnel analyze this information. Information reporting is formatted in accordance with the SOP and the type of communication equipment used. However, intelligence reports are always keyed to the mnemonic (memory aid) SALUTE:

- **S**ize.
- **A**ctivity.
- **L**ocation.
- **U**nit.
- **T**ime.
- **E**quipment.

b. Other reports that the teams may use, such as emergency resupply, communication checks, emergency extraction, should also be formatted in accordance with the SOP.

### 3-15. MOVEMENT TO THE EXTRACTION SITE

The principles of route selection, movement formations, and movement security are observed during movement to the extraction site.

a. **Priorities.** The time that a team remains in enemy territory depends on its mission, composition, and equipment. The exfiltration is critical from a standpoint of morale and mission accomplishment. Plans for extraction by air, ground, or water are made before the operation, with alternate plans for contingencies such as the evacuation of sick or injured personnel. During the mission, the team leader may be faced with an unforeseen situation that may demand the utmost flexibility, discipline, and leadership.

b. **Code Words.** Each team is given code words in the operation order for use during exfiltration. For example, one code word may mean that the team is at its pickup zone. Another may mean that both the primary and alternate pickup zones are compromised and to abort the extraction.

c. **No Communication.** When a team has missed a certain number of required transmissions, the operations section assumes that the team has a communication problem, is in trouble, or both. At that time, the no-communication resupply and exfiltration plan is used.

d. **Alternatives.** Exfiltration of the team may be by means other than air. The operation order may specify exfiltration by land, water, or linkup with friendly forces in an offensive operation. Any of these means may also be planned as alternates in the event the team cannot be extracted by aircraft—or to avoid capture.

e. **Ground Exfiltration.** Despite the desirability of extracting teams by aircraft or linkup, use of these methods may be precluded by security of the team, poor communication, or enemy air defense. Teams must be trained in exfiltration techniques so they can walk out either singly or in groups.

#### **Section IV. EXFILTRATION PHASE**

The exfiltration phase covers the arrival at the exfiltration site to arrival at the debriefing site. Specific actions that normally occur in this phase are —

- Security of the exfiltration site.
- Movement by air, water, land, or any combination of these.
- Arrival in friendly territory.
- Arrival at the debriefing site.

The team is extracted as quickly as possible after the mission is accomplished. An extraction site is always planned for and coordinated with supporting forces; however, the situation may dictate that the team leader decide whether to use the planned extraction site or exfiltrate. The team must be prepared to exfiltrate over predetermined land routes to friendly lines either as a team or in small groups or to exfiltrate to an area for extraction by air or water.

#### **3-16. DISTANCES**

Since LRS operations are conducted deep, distance generally precludes an all-land exfiltration. The initial phase may be by land, ending in extraction by air or by water. However, the team must be prepared to exfiltrate the entire distance unassisted if necessary.

#### **3-17. TERRAIN**

The terrain is important in selecting the extraction means. The extraction site must offer favorable tactical considerations, tide data, PZ suitability, and

cover from enemy direct-fire weapons. The team uses unlikely terrain (such as swamps, jungles, and mountain areas) for extraction.

### **3-18. ENEMY**

Enemy pressure can develop during the extraction. Detailed plans are made for contingency exfiltrations forced by the enemy.

### **3-19. EVASION AND ESCAPE**

Pre-infiltration planning includes the development of an evasion and escape plan. The team leader checks all factors that deal with survival and evasion opportunities. He devises an evasion and escape plan that provides the best chance of survival and return to friendly lines in view of the hazards involved and the mission objectives. He briefs all members of the team on the evasion and escape plan. (See FM 90-18.)

a. Each mission has its own peculiar problems associated with evasion and escape. The devised plan conforms to this unique set of problems, while exploiting the individual capabilities and training of the team members and their supporting air or boat crews. The following generalities apply to evasion and escape plans devised for LRS operations:

- The purpose of the plan is to save personnel who no longer have the means to complete the assigned mission.
- When behind enemy lines, a team's most successful evasions may involve, at some point, air or water movement away from enemy-held territory.

b. Evasion and escape plans cover three phases:

- Phase one occurs after entry into the area of operations.
- Phase two occurs near the area of operations. It allows the team to pursue its mission with a reasonable chance of success.
- Phase three occurs after the mission is accomplished. It is often the most difficult time to evade and escape.

c. The team may be required to hide for several days to allow the enemy to become complacent before trying to move.

d. In selecting extraction sites, the danger of compromising other activities must be considered. Alternate plans must be prepared for unforeseen developments.

e. Linkup with friendly partisans to assist during evasion and escape is possible. Individual team member peculiarities allow identification by the partisans. (See Appendix F.)

### 3-20. EXTRACTION BY AIR

Extraction by air or water is favored when the resources are available and when their use will not compromise the mission.

a. **Considerations.** Other considerations that favor this method are when —

- Long distances must be covered.
- The time of return is essential.
- The enemy does not have air and naval superiority.
- Heavily populated hostile areas obstruct exfiltration.
- The team cannot be resupplied.
- Casualties must be extracted.

b. **Techniques.** Several techniques may be used to extract the LRS teams:

(1) *Helicopter landing.* This is the best method. It lets the team board the helicopter with their equipment in the least time.

(2) *Troop ladder.* The troop ladder allows the team members to board the helicopter. But, if necessary, the helicopter can lift off while soldiers are still on the ladder.

(3) *SPIES or FRIES extraction systems.* Both systems allow rapid pickup of an LRS team on land or in water by helicopter. Personnel are picked up and moved—suspended on a rope beneath the helicopter—to an area where the aircraft can land. The team members then board the helicopter.

(4) *Jungle penetrator.* The jungle penetrator retrieves personnel from areas where helicopters cannot land. It can pick up one to three persons at a time.

### 3-21. LAND EXFILTRATION

Land exfiltration is favored when friendly lines are close or no other means of extraction is available. It is also used when the terrain provides cover and concealment for foot movement of small groups and limits the employment of enemy mobile units against the exfiltrating team. Other considerations favoring this method are when —

- Areas along exfiltration routes are uninhabited.
- The enemy force is widely dispersed or is under such pressure that it is difficult for them to concentrate against the exfiltrating team.
- The enemy force can stop air or water extraction.

- Friendly forces are conducting offensive operations and anticipate movement over or occupation of the area in which the team is operating.

## **Section V. RECOVERY PHASE**

The recovery phase covers the arrival at the debriefing site to notification of follow-on missions. Specific actions that normally occur in this phase are debriefing, equipment maintenance and turn-in, stand-down, and training. This is the last phase of an LRS operation. At the end of this phase, the team begins preparing for future missions.

### **3-22. DEBRIEFING**

As soon as a team returns to the COB or DOB, it is directed to a secure area to prepare for debriefing. In preparing for a debriefing, the team—

- Accounts for all team and individual equipment.
- Reviews and discusses the events listed in the team notebook, from infiltration to return to the operations base, including the details of each enemy sighting.
- Prepares overlays of the team's route, area of operations, infiltration point, exfiltration point, and sighting locations.

The debriefing is normally conducted by operations and intelligence personnel. A communication representative debriefs the RATELO separately after the team debriefing. The team leader is directed to first discuss any enemy sightings since the last communication transmission. Then he gives a step-by-step discussion of every event listed in the team notebook, from the infiltration until the return to the operations base. When the debriefing is over, the team is released for equipment maintenance and turn-in. (See Appendix I for a debriefing format.)

### **3-23. EQUIPMENT MAINTENANCE AND TURN-IN**

All team, individual, and special equipment is accounted for. Team members inspect, clean, and make operator repairs on all individual and team equipment. Equipment is turned in as required. Damaged equipment and equipment with missing components are cleaned, tagged, and turned in. Members report lost equipment.

### **3-24. STAND-DOWN**

After equipment maintenance and turn-in, the team is allowed to stand-down. The length of the stand-down depends on the team's condition

and existing mission requirements. Teams are allowed to relax as much as possible during stand-down; however, OPSEC is still maintained.

### **3-25. TRAINING**

During the stand-down, the team conducts an after-action review. This is conducted regardless of whether the mission was in combat or for training. Strengths and weaknesses from the team's recently completed mission are discussed. A training plan is devised to address results of the after-action review. Training replacement team members may also be necessary. The importance of continued training cannot be over emphasized, because the team could be alerted for another mission at any time.

---

## CHAPTER 4

### SUPPORT

*LRSUs lack the ability to support themselves in terms of combat support and combat service support. Mission analysis may dictate the requirement for combat support and combat service support from outside the company or detachment.*

#### Section I. COMBAT SUPPORT

Combat support consists of operational assistance furnished to the LRSUs by other designated units. This support may become necessary at any time during the insertion, execution, or extraction phase of an LRS mission.

##### 4-1. JOINT SERVICE SUPPORT

The LRSU requires extensive joint service support. The mission and the decision to execute that mission often depend on the amount and type of support available. This is particularly true during insertion and extraction.

a. **Air Force.** LRS teams require assistance from the Air Force for insertion, extraction, or close air support. Specially trained USAF crews are proficient in special operations, low-level flight. These crews can also operate using the adverse weather aerial delivery system. LRS teams are trained and equipped (VHF and UHF radios) to incorporate combat air support assets into their operations in support of target-acquisition missions or self-defense. LRS teams and USAF combat control teams may work together in a joint airborne advance party for specific operations, normally in support of forced entry operations.

(1) *Employment.* Combat control teams provide assistance and guidance to incoming airlift aircraft to the designated LZs or DZs. LRS teams accompany the combat control teams into the objective area. The LRS teams conduct reconnaissance and surveillance operations before the airborne force is deployed.

(a) The combat control teams' missions are to locate, identify, and mark the LZ or DZ and to establish and operate navigational aids and air traffic control communication. Combat control teams assist and guide airlift aircraft to the appropriate LZ or DZ. Combat control teams also remove obstacles and unexploded ordnance with demolitions.

(b) LRS teams surveil one or two named areas of interest in the objective area. The LRS teams observe and report to the ground force commander. One of the assigned named areas of interest is usually the main body LZ or DZ. The LRS team infiltrates with the combat control team



and conducts reconnaissance and surveillance operations on the named areas of interests in the objective area. The team also observes and reports on the status of the LZ or DZ. All reports are sent to the ground force commander over long-range, man-portable communication systems.

(2) *Deployment.* The joint airborne advance party can be infiltrated by air, water, or land. The ground force commander develops plans to deploy the combat control teams and LRS teams during the planning stage of an airborne operation. To reduce the risk to the teams during deployment into the objective area, the airborne and airlift commanders determine the timing for insertion and method of delivery. The commanders consider the requirement for combat control teams to be fully operational in minimum time after reaching the LZ or DZ. This allows navigational, identification, and directional aids to be available for the maximum number of aircraft. Early deployment of the LRS teams is also critical so that detailed and accurate information can be assembled and passed to the ground force commander. Once notified of the impending deployment, LRS teams consider the following actions in planning for the mission.

(a) Perform static line or high-altitude, high-opening parachute operations to insert into the objective area.

(b) Conduct surveillance operations on assigned named areas of interest. The main assault force DZ is treated as a named area of interest.

(c) Conduct surveillance of enemy high-value targets.

(d) Conduct forward area limited observation program to provide limited weather and terrain information to the commander.

(e) Establish communication between friendly forces in the objective area and the task force commander at the home station. For each mission, the LRS team can establish any or all of the following communication nets: HF, VHF, and tactical satellite, if available.

(f) Perform other potential missions as directed by the commander to include: emplace remote sensors; conduct radiological or chemical surveys; direct fire missions for artillery, naval gunfire, or close air support; and conduct pathfinder or linkup operations, or both.

**b. Navy and Marine Corps.** Both the USN and the USMC have units equipped and trained to support ground forces. LRS operations may require the following support:

(1) Close air support from fixed- or rotary-wing attack aircraft against targets in or around the target area.

(2) Suppression of enemy air defense installations by close air support, artillery, or naval gunfire during insertion or extraction.

(3) Fixed- or rotary-wing aircraft support for insertion or extraction.

(4) Small craft support for amphibious infiltration or extraction.

## 4-2. ARMY AVIATION SUPPORT

Army aviation support consists of lift assets for insertion and extraction, or attack aircraft for close air support. LRS teams must be trained to incorporate both of these elements into their operations. Standard aviation support consists of one or two UH-60s and two AH-64s for insertion and extraction.

a. **Lift Assets.** All corps and divisions have organic lift assets available for insertion and extraction of LRS teams. Habitual working relationships and mutual understanding of each other's capabilities, limitations, and SOPs are critical to ensure consistent execution and promote confidence. Aircrews must be proficient at long-range, low-level, and limited visibility penetration into the enemy's rear area. Missions are normally tasked by the G3 Air but are coordinated directly with the appropriate lift unit by the LRS unit. During this coordination, referred to as the air mission brief, a representative from the headquarters, the LRS team, and the air crew should be present.

b. **Attack Assets.** See paragraph 4-3b(2).

## 4-3. FIRE SUPPORT

Surveillance units often depend on multiple sources for their fire support. Coordination of these fires is the responsibility of the LRSU commander and the G3 staff.

a. **Field Artillery.** Due to the nature of LRS operations, many missions will be out of the range of supporting field artillery fires. However, when such fires are available, they are planned for and integrated into the surveillance team mission. LRS teams and corps or divisional field artillery assets lack the command relationships and communication links associated with supported or supporting units. This is especially true of the communication link. Any attempt to integrate fires into the LRS plan must include a detailed communication plan, well-established target lists and priorities, and a simplified chain of command between the team and the firing battery. The following are appropriate missions for LRS teams to plan.

(1) Field artillery cannons and multiple rocket launchers can be planned to suppress enemy air defense artillery defenses as the team crosses the forward edge of the battle area during infiltration and exfiltration.

(2) Field artillery fires can contribute to the deception plan and add combat power to feints used during infiltration and exfiltration.

(3) Teams can engage high-payoff, stationary targets with accurate preplanned fires. The team must be able to observe the target and adjust the fires to be successful.

b. **Aerial Fires.** Due to the distance behind enemy lines at which most LRS operations are conducted, aerial fire support is the prime means of supporting those operations. It may be provided by either fixed-wing or rotary-wing aircraft.

(1) *Fixed wing.* Fixed-wing aerial fire support may come from Air Force, Navy, or Marine Corps units. The type of unit providing support, the aircraft, and the mix of ordnance carried, all affect the fire support planning and coordination process.

(a) The surveillance team can expect to receive fire support from a wide variety of fixed-wing aircraft. Some will be equipped with all-weather strike capability, enabling them to support the team during all conditions. Other aircraft are restricted to fair weather, daylight operations.

(b) If the enemy air defense artillery capability is minimal or can be degraded to a low level, the specially equipped and armed AC-130 aircraft may be used for fire support. A well-planned, well-executed suppression of enemy air defense program, coupled with electronic countermeasures directed against enemy air defense artillery units, normally allows the use of AC-130 aircraft.

(2) *Rotary wing.* The attack helicopter armed with a mix of antitank guided missiles, 2.75-inch rockets, a 20-mm cannon, and 40-mm grenade launchers is an accurate and responsive source of aerial fire support. The increased range and night capability of the AH-64 Apache make it an excellent asset to escort and assist the team as it crosses the forward edge of the battle area. Attack helicopters may be used to conduct feints and demonstrations to cover infiltration and exfiltration.

(a) When attack helicopters are used to support an LRS operation, indirect fires (normally long-range field artillery) are planned along entry and exit corridors to suppress enemy ground fires—specially air defense artillery.

(b) The team may pinpoint targets for the pilot by polar plot, grid coordinate, or shift from a known point. In the case of the AH-64 Apache, the team may use a laser designator. Friendly units mark their locations by panels, lights, mirrors, or infrared sources.

c. **Naval Gunfire.** During infiltration and exfiltration by amphibious means, the LRS team may receive fire support from naval gunfire. Communication between the LRS team and the naval vessel must be closely coordinated using air and naval gunfire liaison company teams.

#### **4-4. AIR DEFENSE ARTILLERY SUPPORT**

Because LRS missions are conducted against second echelon and follow-on enemy forces, Army air defense artillery units are seldom used in direct support of these operations. However, during infiltration and exfiltration, air defense artillery units may support the team as it crosses the forward edge of the battle area.

#### **4-5. ENGINEER SUPPORT**

During retrograde operations or withdrawal of covering forces in defensive operations, surveillance teams may be used in a stay-behind mode. When the tactical situation permits, engineers may be used to prepare underground hide sites and surveillance sites. Topographical engineers may help select positions and may provide computer-generated topographical terrain base products for teams planning missions.

#### **4-6. ELECTRONIC WARFARE SUPPORT**

Depending on the nature of the mission and enemy capabilities, LRS missions may require support from electronic warfare units, especially during the infiltration phase. These electronic warfare operations disrupt, deceive, or destroy the enemy's command and control of his forces and weapons systems, while retaining friendly use of the electromagnetic spectrum. Also, electronic warfare supports deception operations conducted to mislead the enemy by manipulation, distortion, or falsification of indicators to get him to react in a manner against his interests. Active jamming and chaff dispersal can prevent enemy early warning radar from detecting team infiltration and from determining the route of the team. The electronic warfare transmissions make deception plans or feints appear real.

### **Section II. COMBAT SERVICE SUPPORT**

Combat service support consists of the logistical and administrative effort required to maintain long-range surveillance units. The LRSU may need the following combat service support from higher headquarters:

- Maintenance, supply, mess, medical, administration, finance, personnel, and chaplain.
- Packing, rigging, and loading of supplies and equipment for resupply operations.
- Transportation to relocate the unit.
- Infiltration and exfiltration support—air, ground, and water.

#### 4-7. SOURCES

LRS units normally receive CSS from the parent MI organization to which they are assigned. Specific mission requirements dictate CSS channel and relationships with the corps or division assets.

#### 4-8. SUPPLY

Supply operations involve determining requirements and requesting, acquiring, storing, and distributing items to fulfill these requirements. Required supplies are normally carried in by the teams to preclude compromise during resupply. When resupply of deployed surveillance teams is required, a drop point is established well away from the hide site and the surveillance site. The following paragraphs describe the classes of supply and how their supply operations affect LRS missions.

a. **Class I.** Special planning and coordination is required in Class I support of LRS. All elements of the unit must be considered. Base radio stations are ideally collocated with a unit or activity that can provide mess support and security services. The corps or division staff must ensure proper coordination before deploying a station in another unit's area. Support required for the base stations is addressed in the corps or division operation order, or in the corps or division tactical SOP.

(1) Emergency rations in the form of meals, ready-to-eat must be provided to deployed base stations to cover periods when mess support is unavailable.

(2) Deployed teams normally rely on the Class I they can carry into their area of operations. They may also carry freeze-dried rations. For long missions, the team must consider caching rations. Resupply should be the last resort.

b. **Class II Through IX.** These classes of supply are not required in great volume. For normal Army stocked items, the LRSC supply sergeant submits requests to the unit designated to provide support. The LRSD commander submits requests through the unit to which the LRSD is organic or attached. Ammunition requirements include ball ammunition; Claymore mine; and fragmentation, thermite, and smoke grenades.

#### 4-9. RESUPPLY

Resupply operations for surveillance teams are normally planned and coordinated during the planning phase. Teams normally carry all required equipment and supplies into the area of operations. Some missions may require bulky supplies or heavy equipment that cannot be hand carried.

a. Batteries, food, and water are the supplies that usually cause the greatest concern. If the team is airdropped, these items can be quickly offloaded and cached for later use. If the team is inserted into the area of operations by parachute, aircraft can drop initial resupply loads just before the personnel drop.

b. If resupply is anticipated during an operation, one method is to airdrop by door bundles. The team prepares the bundles in advance so they can be quickly loaded and delivered. The following are the five methods of airdrop.

(1) *Door loads.* This load is pushed or skidded out of the aircraft door or tail ramp-opening. This method is suitable for free, low-velocity, or high-velocity drops. The load is limited in size and weight by the opening in the aircraft and by the personnel needed to eject the load.

(2) *Wing loads.* Loads are rigged in containers attached to the underside of the aircraft wings. The size and weight of the load are limited by the load-carrying capacity of the aircraft and by the type of container.

(3) *Gravity.* Loads are rigged within the aircraft. Load-restraining ties are released to let the load slide out of the cargo compartment of the aircraft, while flying with the nose slightly elevated.

(4) *Extraction.* Loads are rigged within the aircraft. A drogue parachute is used to pull out platform loads from the aircraft cargo compartment.

(5) *External transport.* Loads are hung from a hook clevis on a helicopter and dropped using the free, low-velocity, or high-velocity method.

c. Aircraft conducting airdrop resupply deep behind enemy lines must be careful to avoid enemy detection and anti-aircraft fire. The safest way for the airdrop aircraft to penetrate enemy air defenses and remain undetected is often by flying very low. Parachute delivery systems can be used at low-level altitudes.

(1) The high-speed, low-level airdrop system consists of a single A-21 container specially rigged to withstand the shock of the parachute opening when airdropped at high speed. This system can be used to deliver up to 600 pounds per container with a maximum of four containers per pass over the drop zone.

(2) Under certain circumstances, such as when the enemy has a strong low-level air defense artillery system, a high-altitude drop may be best. The aerial resupply and accompanying bundle system can automatically deliver a payload into a small area from high altitudes and substantial lateral distances. This system provides a steerable descent from up to 20,000 feet, at a drop speed of up to 180 knots. It will accommodate payloads up to 500 pounds.

(3) Regardless of the altitude of the parachute drop during aerial resupply operations, the situation frequently dictates delivery during poor visibility using adverse weather aerial delivery system. These system operations can be done safely and effectively in instrument meteorological conditions with a minimum 91-meter (300-foot) ceiling above ground level and a minimum visibility of 0.92 kilometer (0.424 nautical mile).

d. Teams can be resupplied using cache techniques. These caches maybe emplaced by friendly units or local personnel supporting friendly units. (See TC 31-29 for detailed information on emplacing and recovering caches.)

#### **4-10. TRANSPORTATION**

LRSUs have limited organic transportation assets. They require frequent transportation support, primarily to move the surveillance teams and the operations section.

#### **4-11. MAINTENANCE**

Neither the LRSC nor LRSD have organizational maintenance personnel. The communications platoon or section of the LRSC or LRSD perform operator maintenance on communication and electronic equipment. Organizational and direct support maintenance is requested through the unit assigned to provide support.

#### **4-12. MEDICAL**

Organic medical support in an LRSU is limited to self and buddy aid. Due to the remote placement of teams, primary care is not readily available. LRS soldiers should attend combat lifesaver and emergency medical technician training.

a. Additional medical support is requested as needed. When possible, medical evacuation of team members is delayed until the whole team is evacuated from the area of operations. Wounded team members are sent directly to the nearest medical facility that can provide definitive care and treatment.

b. Combat stress is another medical aspect with which surveillance teams must cope. Due to the nature of LRS missions, the teams are subjected to stress in many ways. Some of these contributors are —

- Limited visibility (darkness, smoke, fog, rain, snow, ice, and glare). This requires the extended use of night vision goggles.
- Disrupted sleep cycles. Performance suffers from the disruption of the normal sleep schedule.

- **Mental fatigue.** This results from having to make decisions of serious consequences in too little time, with too little information, and while exposed to danger.
- **Physical fatigue.** This results from conducting physical activity excessive to current conditioning or at a strenuous level without rest.

c. Combat stress, however, is not solely a medical problem. It is also a command problem in terms of reduced performance and personnel lost from duty. It is a command responsibility to take actions to increase the individual team member's resistance to stress. This can be done by extensive training under simulated combat conditions and a high level of physical training. A good diet is also a major factor in coping with stress. This not only includes a balanced diet during combat operations, but also before going on missions. (See FM 26-2 for more information and Appendix K for information on night operations.)

#### **4-13. MISCELLANEOUS SERVICES**

Outside resources must also be used to provide the following services to LRSUs.

a. **Rigger.** The LRSC and LRSD have no organic rigger support. Support for parachute packing, maintenance, storage, and rigging of supplies and equipment for teams must be provided by the airdrop company of the supply and service battalion from corps or theater level.

b. **Finance.** All LRSUs are provided finance service by mobile pay teams dispatched from the area finance service center.

c. **Religious.** Religious service support for the LRSC is provided by the unit assigned to support them. In the LRSD, the chaplain is provided or requested through the unit to which the LRSD is assigned.



## CHAPTER 5

**LRS IN OPERATIONS OTHER THAN WAR**

*Operations other than war are the military activities during peacetime and conflicts that do not necessarily involve armed clashes between two organized forces. Typical peacetime operations include disaster relief, nation assistance, security and advisory assistance, counterdrug operations, arms control, treaty verification, support to domestic civil authority and peacekeeping. (FM 100-5.)*

**5-1. ACTIVITIES**

The range of situations requiring the employment of military forces is as great as the variety of peoples nursing grievances in the world and the possibility of natural and man-made disasters. The training, leadership, equipment, and dedication of hostile groups are all key factors in how US military power is applied. LRSUs can expect to encounter any of the following tasks in support of insurgency and counterinsurgency, combating terrorism, peace enforcement, or peacetime contingency operations.

a. **Support for Insurgency and Counterinsurgency.** These tasks include intelligence operations, joint-combined exercises, populace and resource control operations; counterdrug operations; and tactical operations.

b. **Combating Terrorism.** These tasks include intelligence, surveillance, and security.

c. **Peace Enforcement.** These tasks include observation, surveillance, and information gathering.

d. **Peacetime Contingency Operations.** These tasks include shows of force and demonstrations, noncombatant evacuation operations, rescue and recovery operations, attacks and raids, peacemaking, counternarcotics actions, and support to US civil authorities.

**5-2. PLANNING FACTORS FOR OPERATIONS OTHER THAN WAR**

Planning factors for operations other than war include intelligence, rules of engagement, combined operations, OPSEC, demography, deception, technology, and COMSEC.

a. **Intelligence.** The nature of operations other than war require more detailed intelligence. Teams should have this intelligence before infiltration. This intelligence should be the target location and description, enemy equipment and capabilities; any civilian personnel in the area; and a variety of terrain, weather, and other related facts. Often, this intelligence is not available for the target folders. LRS teams must be given flexibility and

latitude to react to situations as they develop. The duration of the mission, the size of the area of operations, and the information requirements should be flexible to makeup for inadequate information during the planning phase.

b. **Rules of Engagement.** Rules of engagement must be monitored to ensure that all teams know when and how to apply force to meet specific situations. Commanders must avoid rules of engagement that are vague or detailed. Each soldier must understand the rules as they apply to him. LRS teams must adjust rapidly to changes in the rules of engagement.

c. **Combined Operations.** LRSUs must be prepared to coordinate and work with the host country's military and paramilitary forces. Every situation is unique and depends on the extent of involvement of US forces and the nature of the operations. Chief considerations when planning combined operations are command and control, intelligence, operational procedures, and CSS.

d. **Operational Security.** OPSEC is critical for LRS in operations other than war. Due to the potential for other forces (US or host nation) to operate near LRS teams, LRS commanders must carefully coordinate to reduce the risk of fratricide. This requirement poses an equally dangerous risk to OPSEC for the teams.

e. **Demography.** LRS commanders must ensure that all aspects of the local population are studied to understand the effect that local civilians may have on teams operating in the area. Information may be obtained from a variety of sources to include area studies, G2 channels, local government, and even the media.

f. **Deception.** To reduce the risk to LRS teams, commanders should consider deception, particularly during insertion of the teams. False landing zones and dummy radio transmissions are two techniques to deceive the enemy. Deception is limited only by the imagination but should be coordinated through the G2.

g. **Technology.** Technology is a proven combat multiplier. Advanced optics, thermal sights, and remote sensors are available and can increase the capabilities of the LRS teams. Commanders must weigh advantages against the inherent disadvantages, such as increased weight and signature from different types of equipment.

h. **Communications Security.** The threat of interception and direction finding exists in all levels of conflict. Foreign purchases of threat equipment and relatively inexpensive off-the-shelf technology have enabled many Third World countries and indigenous forces to equip themselves with the ability to take advantage of poor COMSEC. LRS commanders and team leaders must take appropriate measures to ensure COMSEC procedures are enforced.

### **5-3. LRS MISSIONS IN OPERATIONS OTHER THAN WAR**

The primary differences between the activities of a LRSU in operations other than war and war consist of the targets it observes and the information it reports. It may observe a coca or marijuana field to discover who comes to tend or harvest the crop. It may observe a terrorist group's safe-house to identify people who meet there. It may observe and report on economic activity such as land use, flooding, drought, salinization, forrest-clearing, and similar activity. It may report on demographic activity such as migration of peoples, legally or illegally, or the racial or religious makeup of a political subdivision. Like all other military organizations, and especially other MI assets, the LRSU should contribute its capabilities for observing and reporting to whatever is required of the total joint, combined, and interagency effort. There are legal requirements and restrictions on some of this activity. Therefore, any list of target types should be accompanied by a warning that the commander should consult his staff judge advocate before beginning any mission.

## CHAPTER 6

**INFILTRATION AND EXFILTRATION**

*LRSU teams must be prepared to conduct several means of infiltration and exfiltration to accomplish a variety of LRSU missions. A team that is prepared to conduct these operations increases its chances of survival and successful mission accomplishment. The methods used to accomplish these missions are waterborne, helicopter airborne, stay-behind, vehicle, and foot movement operations.*

**Section I. WATERBORNE OPERATIONS**

The use of inland and coastal waterways may aid in flexibility, stealth, and speed for the infiltration and exfiltration of a LRSU team. The types of water infiltration and exfiltration may include small boat, surface swimming, helocasting, surface craft, or a combination thereof.

**6-1. PLANNING CONSIDERATIONS**

Before selecting a waterborne infiltration method, the LRS team examines the objective, the beach landing site, the shipping assets available, and the air assets available. The team makes the needed coordination for mission accomplishment. The beach landing site is critical, because it facilitates and supports the inland objective. Some of the factors that determine the feasibility of a beach landing site are hydrography, enemy situation, navigation aids, distance from debarkation point to beach landing site, beach vegetation and conditions, and exit routes from the objective. The infiltration normally takes place during darkness to provide the stealth needed by an LRS team. Also, the environmental factors produced by tides and currents must be suitable for infiltration to be successful. Some other planning considerations include—

- **Time schedule.** A reverse planning sequence of all events of the operation is used as a planning guide. This is included in the initial time schedule.
- **Beach landing site.** The beaching point.
- **Drop site.** Where the team is transported from larger transporting craft into a smaller craft or helocasting site.
- **Embarkation point.** The point where the team is initially loaded onto the transporting craft (going from a mother craft to smaller craft to get to the landing site).

- **Loading.** Loads and lashings, with emphasis on waterproofing, are in accordance with the unit SOP. Inspections by supervisors area must.

**6-2. F470 ZODIAC BOAT**

The LRSU team uses the F470 Zodiac boat for small boat operations. It is inflatable with foot pumps, using four separate valves on the inside of the buoyancy tubes. Each of the valves are used to section off the Zodiac boat into eight separate airtight compartments. The overall length is 15 feet, 15 inches; overall width is 6 foot, 3 inches; weight is 265 pounds; and maximum payload is 2,710 pounds. The crew consists of a coxswain, four paddlers, and a navigator. The boat can be powered by a 40-horsepower short-shaft outboard motor. The team is positioned as shown in Figure 6-1.

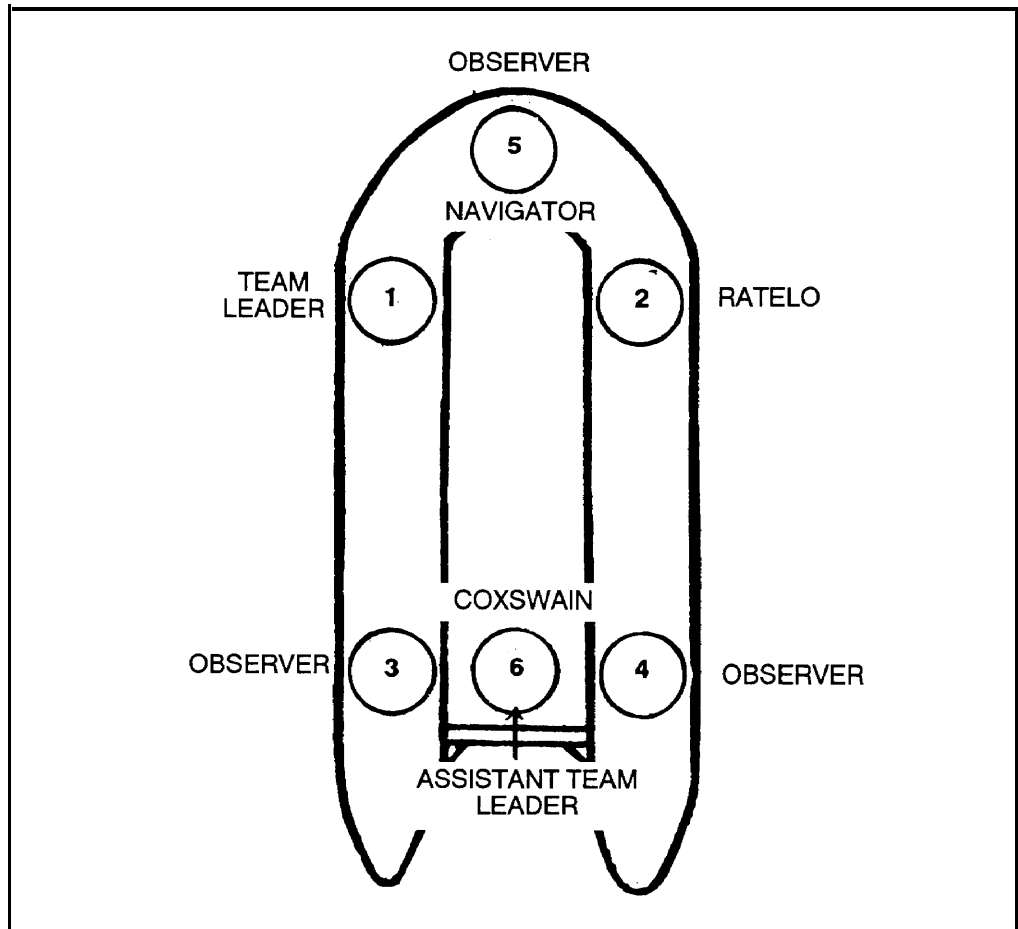

**Figure 6-1. Zodiac configuration.**

- The coxswain (assistant team leader) is responsible for control of the boat and action of the crew. He supervises the loading, lashing, and distribution of equipment. He also maintains the course and speed of the boat and gives all commands.
- The No. 1 paddler (team leader) is the observer. He is responsible for the storage and use of the bowline.
- The No. 2 paddler (RATELO) is responsible for setting the stroke.
- The No. 3 and No. 4 paddlers (observers) are responsible for paddling and flank and rear security.
- The navigator (observer) assists the coxswain; he does not paddle.

a. **Preparation of Personnel and Equipment.** Each person puts on a work vest and a life preserver with harness unbuckled at the waist. The rifle is slung over the life preserver, opposite the inboard side, muzzle down. Radios, ammunition, and other bulk equipment must be lashed securely to the boat to prevent loss if the boat should overturn.

(1) An anchor line bowline is tied with a sling rope into the last V-ring closest to the transom on the floor.

(2) Each team member's rucksack has a snap link attached to the top portion of the rucksack frame to be used as an anchor point to tie down rucksacks.

(3) The coxswain's rucksack is positioned frame forward and behind the last V-ring.

(4) The sling rope is then tied to the front V-ring with a round turn and two half hitches with a quick release.

b. **Launching in Surf.** The coxswain observes surf conditions and considers the intervals of the breakers to time of the boat launching. The coxswain orders the number one and two paddlers to board the boat when they are about thigh deep in the water. As soon as they are aboard, they begin to paddle. The procedure is repeated for the number three and four paddlers. As soon as a wave breaks and the time is favorable, the coxswain gives the boat a final push and embarks.

NOTE: The crew leans well forward to keep their weight forward in the bow. This helps prevent the boat from capsizing and assists in forward momentum.

c. **Beaching in Surf.** The coxswain observes the surf to consider the time to enter. Before entering the surf zone, the coxswain orders the crew to shift their weight to the rear (stern) of the boat to reduce the possibilities of capsizing.

(1) The coxswain and the paddlers keep the boat perpendicular to the waves as the boat enters the surf zone. The coxswain observes the surf and gives the commands to the paddlers to vary the speed of the boat and to avoid plunging into breakers. The coxswain periodically looks seaward to observe the surf. The paddlers never look seaward, because they may lose their cadence and fail to observe the surf to their front. As each wave rises, the paddlers take advantage of the wave's momentum by paddling vigorously.

(2) Upon reaching shallow water, the coxswain orders the paddlers out of the boat in pairs; for example (short count), "Ones, out; twos, out." (See Figure 6-2.) Each pair, on disembarking, immediately grabs the boat handles and begins pulling the boat to the beach.

(3) The coxswain collects the paddles and directs the crew to empty the water from the boat and carry it to higher ground, while the two crewmen provide security.

(4) Once the team has reached the beach landing site, the team searches the area for a suitable cache site for the boat. The team, if properly equipped, may elect to conceal the boat by either subsurface cache, surface cache, or submerge the equipment if possible.

d. **Offshore Navigation.** Offshore navigation may be needed if a team is inserted by going from a larger vessel to their small boat. This type of navigation is confirmed by experienced naval personnel on board the larger vessel. Conventional navigation methods are suitable for conducting boat operations inshore and along streams or in small lakes. During infiltration operations in large lakes and large rivers, supplementary navigation equipment may be required. This is especially true when operations are conducted at night or during other limited visibility. In areas where there is significant marine traffic, buoys and other navigational devices mark the limits of channels and turning points. All of these are marked on charts of the area. These charts may be obtained from marine supply stores, the US Coast Guard, or the US Navy, Such charts should be procured in enough time to allow for translation if necessary.

(1) There may be occasions when precise navigation is essential for mission accomplishment, but the enemy has moved or removed local navigational aids. Aerial reconnaissance, including photographs of the entire area to be traveled, should be requested if time and situation permit.

(2) In areas where currents are a factor, offset navigation techniques may be used. Criticality of currents depends on the distance to shore from the launch point.

- For launches within 460 meters of the beach, currents of .5 knots or greater are critical.
- For launches in excess of 460 meters, a .2-knot current is critical.

NOTE: The speed of a current can be measured by using a bottle partially filled with sand. This moves well and the wind does not affect it. A 1-knot current moves an object 100 feet in 1 minute.

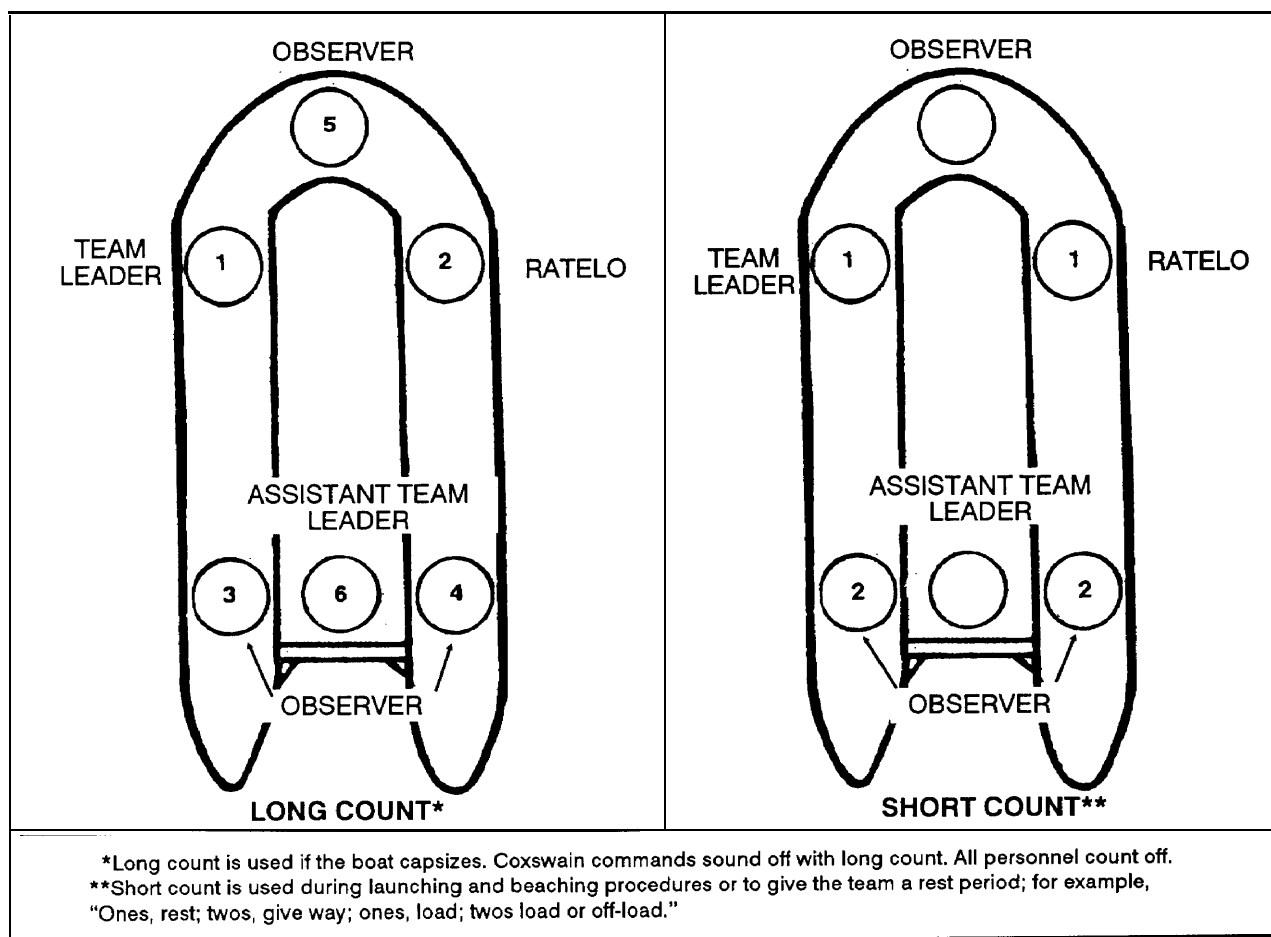

**Figure 6-2. Long and short count configuration.**

The tidal current offset must be computed as follows. This method produces a minimum offset. (See Figure 6-3, page 6-7; the following numbers are keyed to the figure.)



1. From tables 1, 2, and 3 of the National Ocean Survey current tables (furnished by US Navy), the set and drift of the tidal current are computed for the planned launch time at the subordinate station nearest the launch point.
2. On the chart or map that includes the landing point, a line parallel to the coastline is drawn. This line represents the track of the transporting vessel. The track is normally 2 miles offshore (the limit of horizontal visibility for an observer 3 feet above the surface of the water). The distance from the shoreline must be measured to scale. The scale on the map or chart is used.
3. A perpendicular line is drawn from the landing point to the track. This line represents the course of a boat unaffected by a current. The intersection of this line and the track is called the uncompensated launch point.
4. The time required for passage from the uncompensated launch point to the landing point is calculated.

$$T \text{ (time)} = \frac{D \text{ (distance)}}{S \text{ (speed)}}$$

Example: D = 2 nautical miles; S = 2.5 knots

T = 2 divided by 2.5

T = 0.8 hour

NOTE: A seven-man crew of an inflatable boat can maintain a speed of 3.7 kilometers (2 knots) per hour using paddles. If speeds in kilometers per hour are used, then distances must be in kilometers.

5. From the landing point, a line (azimuth) representing the set of the current is protracted. The direction of the set of the current is listed as degrees true as listed in table 2 of the current tables.
6. To compute the effect of the current on the boat, the passage time (step 4) by the drift (speed) of the current is multiplied.

Example: Passage time = 0.8 hour

Drift (speed) = 2.0 knots

0.8 x 2.0 = 1.6 nautical miles (effect of current)

7. This value (effect of the current) is measured along the set line (step 5) using the same scale used in step 2.
8. A line is drawn connecting the uncompensated launch point and the set of the current value on the set line. This represents the course determined by the exposure to the current.

9. The effect of the current on the set line is the factor that must be compensated for by offsetting an equal value on the up current side of the track.

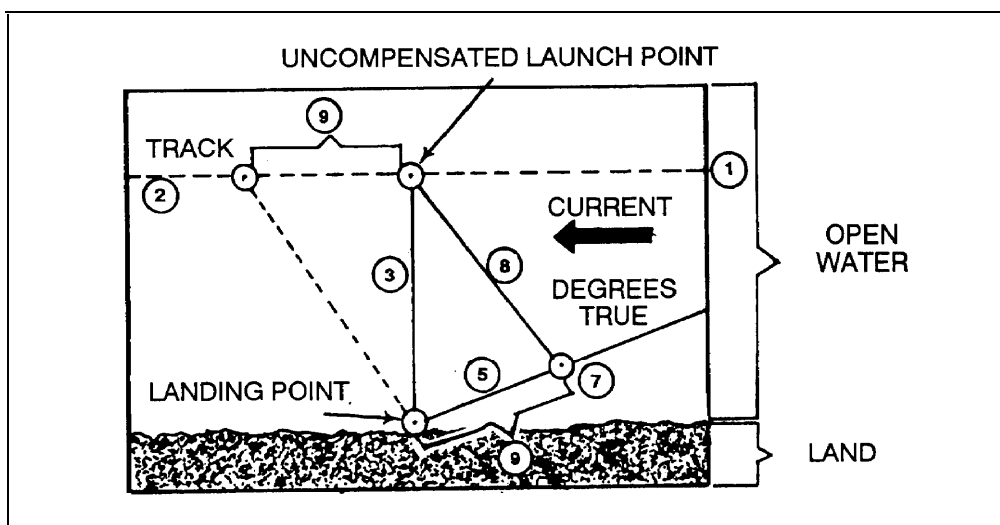

**Figure 6-3. Offset navigation.**

e. **Inshore Navigation.** The LRSU team leader is responsible for navigation. There are two acceptable methods of river navigation.

(1) Checkpoint and general route. This method is used when the drop site is marked by a well-defined checkpoint and the waterway does not have many branches and tributaries. It is best used during daylight hours and for short distances.

(2) Navigator-observer methods. This is the most accurate means of river navigation and can be used effectively in all light conditions. Equipment needed to do this is a compass, photo map (first choice), topography map (second choice), poncho (for night use), and pencil and flashlight (for night use).

(a) The navigator is positioned in the front of the boat and does not paddle. The navigator keeps his map and compass oriented at all times. To check the map during darkness, he uses his flashlight under a poncho.

(b) The navigator keeps the observer informed of the configuration of the river by announcing bends, sloughs, reaches, and stream junctions as shown on the map.

(c) The observer compares this information with the bends, sloughs, reaches, and stream junctions he sees. When these are confirmed, the navigator confirms the boat's location on his map.

(d) The navigator also keeps the observer informed of the general azimuths of reaches as shown on his map. The observer confirms these with actual compass readings of the river.

(e) The navigator announces only one configuration at a time to the observer. He does not announce another until the first is confirmed and completed.

(f) A strip map drawn on clear acetate, backed by luminous tape, may be used. The drawing may be to scale or a schematic. It should show all curves and the azimuth and distance of all reaches. It may also show terrain features, stream junctions, and sloughs.

**f. River Movement.** The characteristics of the river must be known before embarking on river movement. The coxswain, navigator, and No. 1 paddler must watch the water for obstacles, overlapping vegetation, and projections from the bank.

(1) A bend is a turn in the river course.

(2) A reach is a straight portion of river between two curves.

(3) A slough is a dead-end branch from a river. They are normally quite deep and can be distinguished from the river by the lack of current.

(4) Dead water has no current because of erosion and changes in the river course. Dead water is characterized by an increase in snags and debris.

(5) An island is usually a pear-shaped land mass in the main current of the river. Upstream portions of islands usually catch debris and should be avoided.

(6) Sandbars are at those points where a tributary feeds into the main body of a river or stream.

(7) The current in a narrow part of a reach is normally greater than in the wide portion. The current is greatest on the outside of a curve. Sandbars and shallow water are on the inside of the curve.

**g. Maintenance and Storage of F470.** The boat must be washed with fresh water after use in salt or muddy water.

(1) Inflation and deflation valves must be kept lubricated with silicone to prevent rusting and freezing.

(2) The boat must not be left fully inflated for long periods in the sun.

(3) All parts and accessories must be inspected. The boat should be repacked after inspection.

(4) The boat should be stored in a cool dry place out of direct sunlight. It must be stored away from furnaces, steam pipes, boilers, oil, oil contaminated areas, grease, and solvents.

### 6-3. SCOUT SWIMMER

Scout swimmers reconnoiter and secure the beach landing site before committing the entire team on the beach. They are normally employed in pairs. In addition to locating a suitable beach landing site, they must also locate an assembly area, look for suitable cache sites, and locate a position to signal the team.

a. Normally, scout swimmers are launched from a small boat outside of the surf zone. Scout swimmers are equipped with the following:

(1) *Life vest.*

(a) Use: Flotation device for tired or injured swimmer, aides in buoyancy, worn under all equipment except wet suit, no quick-release, never ditched.

(b) Serviceability: Check oral inflation tube; inflate, check for leaks; check CO<sub>2</sub> inflation mechanism.

(c) Preventive maintenance: Freshwater wash after use; clean, lubricate CO<sub>2</sub> mechanism, replace if used; partially inflate and store in dry, cool area.

(2) *Swim fins.*

(a) Use: Aids in swimmer propulsion.

(b) Serviceability: Check for proper fit, check for broken straps.

(c) Preventive maintenance: Fresh water wash.

(3) *Dive tool.*

(a) Use: A tool or knife, prevents entanglements, should not be jettisoned.

(b) Serviceability: Check for rust or corrosion, check for cracked or broken blade, sharpness.

(c) Preventive maintenance: Wash with fresh water, sharpen, and lubricate.

(4) *MK13 day or night flare.*

(a) Use: Emergency signal device.

(b) Serviceability: Check seals (if broken do not use), check pull ring and lanyard.

(c) Preventive maintenance: Fresh water wash, store according to the SOP.

(5) *Coral shoes or booties.*

(a) Use: When working in coral or rocky waters, protection for feet when wearing fins.

(b) Serviceability: Check for rips or holes, check for proper fit.

(c) Preventive maintenance: Fresh water wash, dry out of direct sunlight.

b. Movement to the launch point from debarkation point is normally done by the use of inflatable boats with engines. A launch point is where scout swimmers enter the water and begin their infiltration swim. The launch



point should be no closer than 400 meters to the beach, outside of small-arms weapons range. To accomplish long-distance small boat movement, the infiltration team must be highly skilled in the use of nautical charts and dead-reckoning techniques. Additionally, the team must compute for a compensated launch point using offset navigation to take advantage of tides and current (see paragraph G-1f). Strict noise and light discipline must be maintained throughout the operation.

c. Once the team reaches the launch point, which is outside of the surf zone and small-arms weapons fire, the team leader sends out a scout swim team to reconnoiter the beach landing site.

d. Before leaving the main body, the scout swimmers receive last-minute instructions or adjustments to the original plan based on observations made during the infiltration thus far. The scout swimmers' rucksacks are left with the main body (in the inflatable boat). To keep their direction, the scout swimmers use a dive compass or guide on prominent terrain features or lights on the beach. Scout swimmers use the sidestroke to allow all-round observation while approaching the surf zone or the beach landing site. Swimmers face each other using opposite sidestrokes and observe the area beyond the other swimmer.

e. As the scout swimmers reach the surf zone or when they get close to the beach landing site, they use the breaststroke to observe the beach. The scout swimmers must use stealth and caution while approaching the beach and keep a low profile in the water as well as when on the beach. One scout swimmer should periodically keep watch to the rear to warn of large waves that may injure the swimmers or separate them from their equipment. When the scout swimmers reach shallow enough water and when they determine that the situation is safe enough, they remove their fins. There are two methods the scouts may use to move across the beach to begin their reconnaissance and secure the beach landing site.

(1) If the wood line can be seen easily from the waterline, one scout remains in the water just at the waterline and covers the movement of the other scout as he moves quickly across the beach. Once the inland scout has moved to the edge of the wood line, he covers his partner while he moves across the beach to the same position.

(2) If the beach topography is such that the wood line cannot easily be observed from the waterline, the above method can be modified to include successive bounds.

f. Once both scouts have moved inland, they employ a modified box pattern to reconnoiter and secure the beach. The scouts agree on a suitable assembly and cache site when they finish their reconnaissance. One scout then positions himself at the edge of the wood line to provide security for

the main body's landing and from which he can guide the main body to the assembly area. The other scout positions himself where he can signal the main body. As soon as he sees the main body, he moves to the waterline.

g. When the main body reaches the beach landing site, the scout at the waterline directs them to the other scout who guides them to the assembly area. After the last team member has passed him, the scout at the waterline disguises any tracks left in the sand and then rejoins the main body.

h. If at all possible, the cache site and the assembly area should be different locations. If the enemy discovers and follows the tracks or trails from the beach to the assembly area, he can easily determine the number of personnel involved in the operation by counting the swim gear. Additionally, the cached equipment maybe needed to support exfiltration at another location.

#### **6-4. HELOCASTING OPERATIONS**

Helocasting can be an effective means of inserting and extracting LRS teams and equipment. The speed, range, and lift capability of rotary-wing aircraft make them excellent waterborne delivery and recovery vehicles. Helocast preparation considerations are as follows.

a. When planning for the number of personnel per type of aircraft, the leader uses the standard troop-loading planning figures. These figures are adjusted depending on aircraft configuration, type of equipment, and casting or recovery procedures. These items are coordinated in advance with the aircrew.

b. A rehearsal of the operation is conducted to include all jumpers, the crew, the accompanying equipment, and support personnel. The leader emphasizes body exit position, exit timing, commands, and water entry position during live casting rehearsals.

c. All equipment is attached to the jumper using 1/4-inch 80-pound test cotton webbing. This normally includes masks, fins, web belts with knives, and flares. The leader ensures all jumpers wear life vests.

d. The team applies the following procedures to rubber boat operations.

(1) Tie down and secure all equipment inside the boat.

(2) Secure the motor in the floor of the boat and pad it with honeycomb cardboard.

(3) Securely attach and isolate the gas can.

(4) Secure the paddles under the gunwales, out of the way of the rest of the gear.

(5) Secure the rucksacks as tightly as possible to the deck of the boat.

(6) Waterproof all equipment in the boat as if it was to be taken subsurface.

(a) Regardless of the type of aircraft used, tie down or secure all loose or unnecessary equipment. Tape or pad all sharp edges or items.

(b) If using side doors for casting (UH-60 or UH-1H), secure the doors in the open position, and tape all edges.

(c) With a CH-46 or CH-47, ensure the ramp is secured in the open or casting position (10 degrees below horizontal).

(d) If a wire ladder is to be used for recovery, secure it on the floor to a "wire donut" (must be 5/8-inch wire and secured in at least five points with snap links).

(e) For effective communications, ensure all personnel use the same frequency. (Cast master, pilots, and safety boats).

(f) Ensure the casting area is clear of all surface and subsurface obstacles.

e. When helocasting from a ramp, such as a CH-47, the cast master gives the following commands: "Get ready," "Stand up," "Check equipment," "Sound off with equipment check," and "Go." When using UH-60 or UH-1H, delete "Stand up."

(1) If using an F470, the team moves it to the end of the ramp. Just before the command GO, the F470 should be pushed out until about half of the boat is past the edge of the ramp. When the command GO is given, it will be easy to push the boat off the ramp.

(2) The cast master ensures jumpers do not remove seat belts until the command GET READY is given.

(3) The cast master ensures the pilot does not exceed 10 feet of altitude (above ground level) and 10 knots of speed when dropping personnel.

(4) When casting from the ramp, jumpers assume a normal prepare to land attitude.

(5) When casting from a side door, jumpers cast from a seated door position. On the cast master's command, jumpers push off and face the direction of flight, assuring a normal prepare to land attitude.

(6) Bundles or rucksacks are thrown before the jumper exists on the command GO.

(7) Upon entering the water, the jumper gives an "okay" signal to the cast master and safety boat.

f. When using a single rotor aircraft for recovery operations, a wire ladder is lowered to the swimmers who are on-line at 50-meter intervals in the recovery area.

(1) As the aircraft flies over, the swimmers hook the lowest rung on the ladder with their leading arm and to a designated height where they hook up (with snap link and rope seat) to the ladder.

(2) CH-46 or CH-47 aircraft will land in the water.

(a) If using a rubber boat with motor, the team drives the boat up to the ramp.

(b) When not using a motor, a rope hooked to the aircraft's winch that has a 10-pound padded weight attached is lowered. The rope is lowered behind the boat and dragged over it. The swimmers secure the rope and the winch pulls the boat in.

(3) When recovering only swimmers, they either go up a ladder or, if the aircraft is on the water, they swim up to the ramp.

(4) Swimmers put on their harnesses before the helicopter's arrival if being recovered by SPIES (paragraph 6-6.). The helicopter hovers over the group of swimmers as they attach their harnesses to the D-ring.

g. Due to the hazards involved, the leader emphasizes safety in all aspects of planning and executing helicopter casting and recovery operations.

(1) Immediately before a helocast and recovery operation, the leader physically reconnoiters the casting area to verify water depth and the absence of obstacles and debris.

(2) He ensures water depth is not less than 15 feet.

(3) He ensures motorized safety boats are in the water with motors running to conduct helocasting and recovery operations.

(4) He establishes radio voice communications between the safety boats and the drop aircraft.

(5) He has one standby diver, with complete scuba gear, in the safety boat.

(6) He ensures the cast master has voice communications with the pilot.

(7) He ensures drop altitude does not exceed 10 feet above surface of the water.

(8) He ensures drop speed does not exceed 10 knots indicated airspeed.

(9) He ensures there is a qualified aidman in one of the safety boats.

(10) In the event of an injured swimmer, he ceases helocasting and recovery operations until the cause and extent of the injury are determined.

## **Section II. HELICOPTER OPERATIONS**

Helicopters provide a variety of methods for infiltrating and extracting teams.

### **6-5. RAPPELLING**

Rappelling can provide a team a means of quick insertion with or without an LZ. It can be done regardless of terrain or the availability of LZs. (See TC 21-24 for more information.)



### 6-6. SPECIAL PATROL INFILTRATION/EXFILTRATION SYSTEM

The SPIES can provide an excellent form of exfiltration for LRS teams over short distances. SPIES is not recommended for infiltration because team members are exposed the entire time. The nature of SPIES operations is such that a thorough briefing is required for all participants before the operation is conducted. For personnel being extracted, they must receive extensive training in the SPIES extraction before infiltration. For the other personnel involved, a complete preoperations briefing is held before the operation starts. This is especially crucial in a situation where additional assets are involved, other than the extraction helicopter (gunships, aerial observers, artillery support, and so on). (See TC 21-24 for more information.)

a. **Familiarization.** As in all training conducted by LRS units, all operations using the SPIES must be preceded by a safety briefing. The briefing should consist of but not be restricted to a review of—

- All of the equipment associated with the SPIES and its characteristics.
- How to inspect it before use.
- Proper donning of the harness.
- Methods of extraction and insertion used.
- Emergency signals that all personnel are required to know.

When time and situation permit, personnel who are not familiar with SPIES are encouraged to watch or take part in the rigging of the helicopter. This not only builds personnel confidence in the equipment, but it assists in a more comprehensive training of new SPIES masters. All individuals not familiar with SPIES use it the first time without combat equipment to instill confidence and to become familiar with SPIES procedures.

b. **Communications.** Because of the noise associated in all helicopter operations, radios must be used to communicate. Radios are used to communicate before the arrival of the helicopter. Precise arm-and-hand signals must be established in the event of radio failure or poor communications. During the first part of the operations, the SPIES master must observe (daytime) or know that a definite procedure is taking place (night or jungle) while the teams are hooking up to the SPIES rope for extraction.

(1) When it is possible, headsets and voice suppressors should replace the handset for better radio procedures. This allows the radio operator on

the ground to use both hands while the helicopter comes to a hover for a faster and safer hookup.

(2) If radio communications are hampered in anyway, a specific set of procedures and hand-or-light signals are followed.

c. **Extraction.** After the team has been located, the SPIES master must assist the pilot in directing the helicopter to the proper distance over the team. At this point, the team leader should be in a position to move and approach the rope as it is dropped by the SPIES master. Once the rope is clear of any obstacles, the team leader signals the team to their assigned positions along the 10 hookup points. Using the primary, or harness snap link, each team member hooks to the D-ring on his side of the line. This is the primary hookup. Once this is done, he then hooks into the alternate or second hookup point, using the safety line and snap link. Then, he should face forward along the line so that he is heading in the direction he is traveling when the aircraft starts its ascent. The SPIES rope should be held up and routed over the shoulder closest to the rope. With the other hand, he gives a thumbs-up signal to allow both the team leader and the SPIES master to see he is ready to go. Once all the team members have done this task, the team leader physically inspects (if time and situation permits) or hooks himself in on the lowest point along with the radio operator to ensure the running end is clear of all obstacles and gives the thumbs-up signal to the SPIES master. This thumbs-up signal, at night an arranged light signal, will continue until a safe altitude is reached. The helicopter may start a transition in a horizontal direction on its return flight.

d. **Emergency Procedures.** During the flight, from extraction until the team is safely and quickly detached from the SPIES rope, there should be a conscientious effort on the part of each team member to be aware of any problem which may arise from above or below. The soldier above checks the soldier below. At the first sign of danger or if there is an emergency, the team leader or a team member places his freehand on his head. The SPIES master, on observing anyone on the SPIES rope with his hand on his head, instructs the pilot to make an emergency landing in the nearest and safest area.

e. **Dismounting Procedures.** The familiarization training phase is the time to ensure all members are aware that when the terrain allows, and on reaching the ground, they should immediately head in the direction of the nose or 12 o'clock of the aircraft. This allows the pilot to see that the team is out from under the aircraft. If an emergency situation with the helicopter arises at this point, the pilot can make a better appraisal of the situation if he can see all the members of the team at the 12 o'clock position. If the helicopter is making a scheduled landing at this time, the team ensures that

the SPIES rope does not interfere with the aircraft and ensures that the aircraft does not land on the rope.

f. **Operational Training.** In preparing for an operation, if the situation, mission, and or terrain suggests the possibility of a SPIES extraction, the leader should include the SPIES harness in each individual's equipment list. If the mission or insertion precludes the wearing of the harness during the mission, it should be carried inside the pack being used. Once the extraction helicopter has been requested, the harness may be retrieved and donned before extraction.

g. **Land Extraction Procedures.** The SPIES should be used only in those cases where the team requires immediate extraction or cannot move to a clear (open) position suitable for helicopter landing.

(1) The extraction helicopter(s) proceeds to the area and radio or visual contact with the team is established. The backup helicopter equipped with the SPIES remains aloft and away from the area, but maintains visual contact with the LZ and monitors radio communications.

(2) The SPIES master deploys the rope; then notifies the pilot the rope is out. The pilot can neither see the team nor determine the most suitable position for the aircraft. Above the extraction site, the SPIES master gives the pilot vertical and lateral corrections until the aircraft is in the desired position. These commands are given as follows: left, right, forward, rear with the estimated distance; for example, "left, 10 feet." The SPIES master then counts down (as the pilot responds); for example, "ten, nine, eight, seven, six hover, hold, ropes out." The SPIES master informs the pilot of any unexpected drift occurring that could cause the team to be pulled through an obstruction. These commands or directives are given in conjunction with the crew chief, whose primary attention is to the safety of the aircraft, and any possible interference of the tail rotor.

(3) The team should hookup the same as in familiarization procedures and sling individual weapons over the shoulders. Weapons and equipment are secured to withstand the wind. Rifles should have a safety line attached to prevent a lost weapon during SPIES operations. The team leader gives the thumbs-up signal.

(4) During the extraction, the team radio operator maintains communications with the extraction helicopter. He gives an oral backup to the thumbs-up signal and also relays any other information during the flight. His location should be near or at the bottom hookup point to assist in giving accurate information about the extraction, the clearing of obstacles, and the descent.

(5) Liftoff of the extraction aircraft must be vertical until the SPIES rope has cleared all obstacles. Team members can fire their individual weapons,

using the hip position and with the barrel directed downward at a 45-degree angle and outward.

(6) Once the aircraft has cleared vertical obstacles, the RATELO, who is the lowest man on the SPIES rope gives the signal to the pilot that the team has cleared the obstacle. This is especially important during limited visibility even when the pilot is using night vision goggles, because of the difficulty in determining depth perception 120 feet below the aircraft.

(7) On descent, the RATELO along with the SPIES master communicates to the pilot the altitude, drift, forward speed and whether or not oscillation of the rope is great enough to cause injury on impact. The RATELO should use the countdown method in 10-foot increments (“fifty, forty, thirty, twenty, ten, nine, eight . . . one; one man down, two . . .”) until the team is down. During limited visibility, the SPIES master may not be able to see this action.

(8) The SPIES master must monitor drift once the team is on the ground. Sudden lateral shifts may drag team members before they can disconnect from the rope.

**h. Water Extraction Procedure.** The SPIES is also suitable for extracting LRS teams from the water. For this procedure, three inflatable life vests or any type of flotation device is tied to the SPIES. A flotation device is tied to each end of the attachment points; one flotation device is tied in the middle of the attachment point area, just above the middle two sets of D-rings. Each team member should wear his SPIES harness under his life vest. He may also wear swimming fins, mask, and snorkel (amphibious operations) to ease hooking up to the SPIES rope within the spray area beneath the hovering helicopter.

(1) After the extraction aircraft has attained a stable hover above the team member’s, the SPIES master drops the SPIES rope (with flotation attached) on order from the pilot.

(2) When the team members have completed hookup to the SPIES rope, the team leader signals the SPIES master to start liftoff.

(3) Aircraft liftoff must be vertical until all team members and the bottom end of the rope have cleared the water. During the initial liftoff, team members must know that they are going to be dragged through the water. They should be prepared to roll on their backs until clear of the water.

(4) Flight speed and altitude should be the same as over land. The dismounting procedures also remain the same, except when landing on a ship. Once on board, all members must take their orders from personnel in charge of the deck.

i. **SPIES Master Qualifications.** The commanding officer must ensure that this qualification is entered on the soldier's record. To be a SPIES master the soldier must have the following qualifications.

(1) Be at least a sergeant or above (may be waived by the commanding officer).

(2) Must have participated in at least three SPIES operations. For example, have hooked up the helicopter and assisted in preparation of an operation and conducted successful operations under the supervision of a qualified SPIES master.

(3) Know all aspects of a SPIES operation.

(4) Be able to give an effective pilot's brief.

(5) Be able to use aircraft communications equipment and understand aviation terminology.

j. **SPIES Master Duties.** The SPIES master is responsible for the safe conduct of the SPIES operation. Preflight duties of the SPIES master are—

(1) Inventory and inspect all SPIES equipment.

(2) Brief pilots and other concerned personnel about details of the operation, especially the extraction and dismounting procedures.

(3) Ensure that he has an Interagency Communication System helmet and gunner's belt or sling rope if no belt is available. Connect and check the operation of the Interagency Communication System to be used. (Interagency Communication System communications must be established between the SPIES master and pilots on all SPIES operations.)

(4) Attach the SPIES rope to the helicopter in accordance with the guidance in this chapter.

(5) Ensure that there is nothing adrift in the aircraft that may fall on a team member later.

(6) Check the location of the emergency axe. Ensure it is readily available, yet secured enough so as not to endanger the soldiers on the SPIES rope. (The axe should be inspected to ensure that it is sharp.)

k. **Extraction Duties of the SPIES Master.** On arrival at the team's estimated position, the SPIES master assists the pilot to determine the exact location of the team members.

(1) As the aircraft approaches the team's location, he aids the pilot (using the clock system) in placing the aircraft directly above the team.

(2) He requests permission from the pilot to drop the SPIES rope when the aircraft is hovering above the team.

(3) He drops the rope, taking care to avoid striking team members on the ground.

(4) He notifies the pilot when the rope is down, and reports any altitude corrections necessary to ensure that all SPIES attachment points can be reached by the team members.

(5) He watches for the thumbs-up signal from the team leader.

(6) On receipt of the thumbs-up signal, he advises the pilot that the team is ready for extraction and requests a vertical liftoff.

(7) He advises the pilot of the team's approximate position, the location of any potential obstacles, and the avoidance of horizontal movement.

(8) If a team member becomes entangled with an obstacle during the extraction, he notifies the pilot immediately and requests that the vertical lift be stopped. If the situation is critical, he is prepared to cut the SPIES rope (the anchor point or cargo straps) after team members are secured to the obstacle or on the ground.

(9) When he is sure that all obstructions have been cleared, he advises the pilot. The pilot obtains a safe altitude (about 500 feet above ground level for training purposes or as the situation dictates in combat) or transitions into forward flight.

(10) At frequent intervals during the flight, he advises the pilot on the safety status of all team members. He constantly watches the team and checks the security of the SPIES attachments often.

**1. Dismounting Duties.** On arrival at the dismounting area, the SPIES master informs the pilot the approximate height of the lower rope end from the ground.

(1) Once the pilot starts the vertical descent, he continually informs the pilot the approximate distance the lower rope end is above the ground.

(2) He informs the pilot of any horizontal drift that may occur and any obstructions near the SPIES rope. Also, he keeps the pilot informed of any swinging or rotating that may occur.

(3) He informs the pilot when the rope is about 25 feet above the ground and again when it is 10 feet above the ground. He ensures that the rate of descent is slow enough to enable the team members to land and get out from under team members safely.

(4) He reports initial touchdown of the rope, when the last team member has safely started to move away from under the helicopter, and when all team members are disconnected.

(5) On order of the pilot, he either retrieves the SPIES rope back into the helicopter or disconnects the SPIES rope and drops it to the ground. While using the UH-1H helicopter, the only way to retrieve the SPIES rope while in the air is by having an arranged recovery rope attached. This can be done with a 12-foot sling rope. In some cases, two

6-foot-long sling ropes joined together can be used to haul the SPIES rope aboard. The rope may be attached about 5 or 6 feet below the cargo hook or cargo strap hookup point. The type of knot used to connect the sling (or recovery) rope to the SPIES rope must be self-tightening in nature; for example, the Prussik knot. The standing end of the sling rope may be fastened to the deck tie-down or by using a snap link. Although the line should be kept out of the way, the primary consideration should be its length. It must be long enough for any swinging or rotating in the SPIES during flight.

m. **Inspection.** The SPIES is inspected by a certified rigger when serviceability is questioned by the SPIES master and at six-month intervals. Outdated, spliced, abraded, or cut rope is removed from service. The SPIES master performs the following inspection.

(1) Inspects harness and suspension sling webbing for signs of contamination from oil, grease, acid, rust at points of contact with metal parts, cuts, twists, fading, excessive wear, or fusing (indicated by unusual hardening or softening of webbing fibers), fraying, burns, abrasions, and loose or broken stitching (in excess of three stitches). Removes damaged harness or suspension sling. Returns damaged equipment to supply for appropriate disposition.

(a) Inspects all hardware for signs of corrosion, pitting, ease of operation, security of attachment, bends, dents, nicks, burrs, and sharp edges. (Replacement of hardware [except chest strap adapter] that requires unstitching of webbing makes the harness unserviceable.)

(b) Replaces the V-ring by cutting the strap above the stitching. Folds and stitches a new end section of the leg strap. If damaged, returns harness or suspension sling to supply for appropriate disposition.

(2) Checks rope, harness, and suspension slings for expiration: 7 years of service (opening manufacturer's package) or 15 years from date of manufacture, whichever occurs first.

(3) Ensures rope is free of splices.

(4) Inspects the rope surfaces for cuts, excessive abrasions, and snags. (Cuts on the rope are excessive when there are four or more cut strands in any 5-inch length. The 2-1 braided rope has 12 pairs or 24 strands around the circumference. Abrasion is extensive when torn yarns are equivalent to that of four strands of any 5-inch length. Rope that has been subjected to heavy loads may display glazed areas where it has worked against hard surfaces. This condition may be caused by paint or the fusing of fibers. Also, after long use, the rope may become fuzzy on the surface

[although this should be minimized with the surface coating]. In either case, the effect on the rope's strength is negligible.)

(5) Inspects rope for signs of contamination by acid, alkaline compounds, salt water, fire extinguishing solutions, and petroleum based solvents. (Although the ropes in use gradually change color, such changes do not indicate a decrease in strength, unless the change is due to contact with strong chemicals. Changes in color caused by chemicals, however, probably will be spotty. Changes that occur because of use will be uniform throughout the length of the rope.)

(6) Ensures the eye loop at the end of the SPIES rope is not broken, frayed, or loose.

n. **Repairs and Cleaning.** To repair and clean the SPIES, the SPIES master performs the following:

NOTE: Loose or broken stitching in excess of three stitches will not be repaired.

(1) Washes contaminated ropes with a mild detergent (such as liquid dish soap) and cold water, followed by a rinse in clean, fresh water. Dries at a temperature not to exceed 140 degrees F.

(2) Removes stubborn oil, grease, hydraulic fluid, and other petroleum stains with the cleaning agent xylene (Grade A or B, TT-X 916). Uses the cleaning agent as directed.

**WARNING**

**ACID CONTAMINATION, CUTS, OR FRAYING OF HARNESS OR SLING WEBBING CONSTITUTE NONREPARABLE DAMAGE.**

o. **Storage.** The SPIES master stows the SPIES as follows:

(1) Protects nylon materials from direct sunlight as much as possible to avoid ultraviolet deterioration.

(2) Stows the SPIES rope in an aviator's kit bag for protection when not in use.

(3) Uses bins or similar facilities for storage of SPIES equipment. (Shelves used for storage should be at least 4 inches from the walls and 12 inches from the floor. Areas used for storage should be well ventilated and free of oil, acid, cleaning compounds, and other contaminants. Equipment must not be stowed above or near hot water pipes, heating apparatus, or in direct sunlight.)

p. **Organization for SPIES Extraction.** The SPIES master—

(1) Issues harnesses.



- (2) Ensures soldiers don harnesses.
- (3) Inspects soldiers wearing harnesses.
- (4) Inspects the secondary safety line bowline around the chest with an end-of-line bowline.
- (5) Organizes sticks with up to six soldiers.

q. **Rigging a UH-1H Helicopter for SPIES Operation.** The UH-1H may or may not have a cargo hook. The following equipment is required:

- SPIES rope.
- Two 11-foot 3-loop cargo slings (type 26)(four without a hook).
- Two 9-foot 3-loop cargo slings (type 26)(four without a hook).
- Two Type IV connector links (four without a hook).
- One 120-foot rope.
- Four locking snap links.
- One 12-foot sling rope.

(1) The primary attachment point for the SPIES rope is the cargo hook. The end of the SPIES rope having a polyurethane encapsulated eye is attached to the cargo hook. The two, 9- or 11-foot-long, cargo suspension slings are joined together to form one continuous sling, using a Type IV link. This sling is then stretched out on the helicopter deck. One end is taken under the helicopter and through the eye of the SPIES rope and connected on the other end of the sling using a Type IV link assembly. The sling must pass between the helicopter skids and the fuselage. Locally procured padding may be used to protect the sling from damage.

(2) Once the SPIES rope and cargo straps are in place, the straps running across the deck of the helicopter must be secured in place by at least four and as many as eight snap links. These are to be evenly spaced across the deck and alternated from one side of the strap to the other and top and bottom so that the first snap link will be to the rear of the strap and going around the bottom two straps and the next snap link will be in the front of the cargo strap and go around the top two sections of the strap. This is continued until at least four points have been established. If eight snap links are available, then each tie-down will have two reversed.

(3) If there is no hook or if it is not working properly, it is safe to use the SPIES by doubling up on the cargo slings and Type IV links, so that there will be two cargo straps side-by-side or a total of four slings and four Type IV links.

(4) The team must use caution when using the UH-1H helicopter because of the ways in which it may be outfitted. Some may have a step attached. This is an added obstruction not only during installation, but during the operation as

well. Others may have rocket pods or machine guns mounted. Not all of the UH-1's are hooked up exactly the same way every time.

r. **Rigging a UH-60 Helicopter for SPIES Operation.** UH-60 may or may not have a cargo hook. The following equipment is required:

- One 120-foot SPIES rope.
- Two 11-foot 3-loop cargo slings (four without a hook).
- Two 9-foot 3-loop cargo slings (four without a hook).
- Two Type IV connector links (four without a hook).
- One 120-foot rope.
- Four locking snap links.
- One 12-foot sling rope.

(1) The primary attachment point for the SPIES rope is the cargo hook. The end of the SPIES rope having a polyurethane encapsulated eye is attached to the cargo hook. The two 9- or 11-foot cargo suspension slings are then joined together to form one continuous sling using a Type IV link. This sling is stretched out on the helicopter deck and one end is taken under the helicopter and through the eye of the SPIES rope. It is then connected on the other end of the sling using a Type IV link assembly. Locally procured padding may be used to protect the sling from damage.

(2) Once the SPIES rope and cargo straps are in place, the straps running across the deck of the helicopter must be secured in place by at least four and as many as eight snap links. These are to be spaced evenly across the deck and alternated from one side of the strap to the other and top and bottom, so that the first snap link maybe to the rear of the strap and going around the bottom two straps and the next snap link may be in the front of the cargo strap and go around the top two sections of the strap. This is continued until at least four points have been established. If eight snap links are available, then each tie-down will have two snap links connecting the same spot and the swing gates are reversed.

(3) If there is no hook or if it is not working properly, it is safe to use the SPIES by doubling up on the cargo slings and Type IV links. There will be two cargo straps side-by-side or a total of four slings and four Type IV links.

s. **Rigging a CH-46 or CH-47 for SPIES Operation.** The CH-47 does not have a cargo hook. (See Figure 6-4, page 6-24.) The following equipment is required:

- Two 11-foot 3-loop slings.
- Two 9-foot 3-loop cargo slings.
- Four Type IV connectors.
- One 13-foot sling rope.

(1) The SPIES rope is attached using two 9- or 11-foot cargo suspension slings and four Type IV links. The cargo slings are passed through the encapsulated eye of the SPIES rope and attached to the outboard cargo tie-down rings on the aircraft floor. Two tie-down rings are used for each sling. Locally procured padding may be used around the edge of the cargo hatch to protect slings from damage.

(2) Not all of the tie-down rings are going to be in the exact same position on all helicopters. This will be one of the main considerations in deviating from the prescribed installation procedures. However, when it is possible, the cargo straps should be placed to form two U-shapes. One is placed forward of the cargo hole in the center of the aircraft floor and one aft or toward the rear of the helicopter. The cargo straps hold the SPIES rope comfortably in the center of and slightly below the opening of the cargo hatch. The use of snap links attached close to all four tie-down points not only ensure a backup in case of a faulty tie-down ring, they also reduce the amount of movement in the cargo suspension straps. A total of eight snap links should be used. Two at each point with the swing gates are reversed for added security.

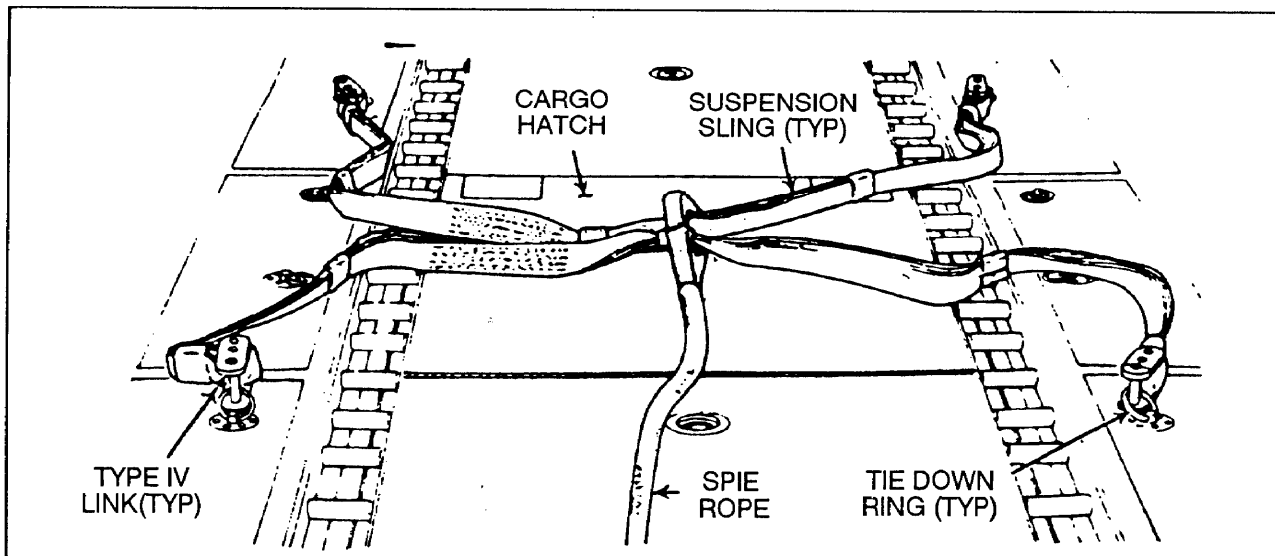
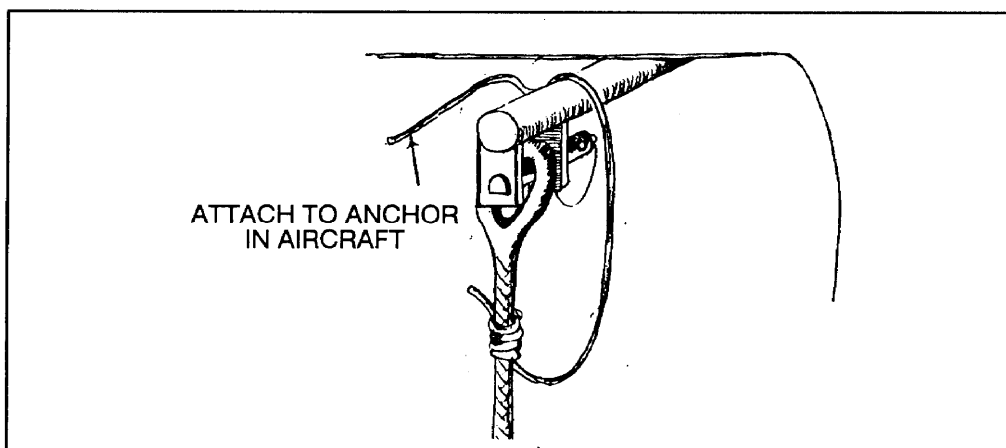

**Figure 6-4. CH-46 or CH-47 helicopter SPIES rope attachment.**

**6-7. FAST-ROPE INFILTRATION/EXFILTRATION SYSTEM**

The FRIES comes in 50-, 60-, 90-, and 120-foot lengths and 3 inches in diameter. Before conducting a fast-rope operation, a thorough inspection of the fast rope is necessary.

a. **Inspection of the Rope.** The rope must be laid out to inspect the entire rope. The eyelet on the end should be checked for excessive wear. The rope must be checked along its entire length for fraying. Snags in the rope from normal use will not significantly weaken the rope. However, a rope with fraying of several strands in one particular spot must not be used. If the fast rope becomes wet, it must be S-folded or hung in a dry, warm area to dry before further use. If the fast rope is used in saltwater, it must be washed in fresh water before drying. The rope must also be inspected for contamination of acid, alkaline compounds, salt water, fire extinguishing solutions, or petroleum-based solvents. Although used ropes gradually change color, such changes do not indicate a decrease in strength, unless the change is due to contact with strong chemicals. Changes in color caused by chemicals will probably be spotted; changes occurring because of use will be uniform throughout the length of the rope.



**Figure 6-5. Fast rope rigged to UH-60.**

b. **Rigging of fast rope in a UH-60.** (See Figure 6-5.)

(1) Both cargo doors are locked in the open position.

NOTE: For arctic or other cold weather operations or during flights of long duration, the cargo doors may be closed and locked until the time specified for opening time.

(2) The center row (nine) troop seats are removed.

(3) Floor restraint provisions are provided to fast-rope personnel while aircraft is in flight. (Seat belts or CGU strap).

(4) The fast-rope master or safety extends the fast-rope bar and inserts the pit pin in the bar.

(5) The fast-rope master inspects the bar for cracks and frays.

(6) The fast-rope master rigs the fast rope to the fast-rope bar:

- Places one retainer device on the fast-rope bar.
- Slides fast rope onto the fast-rope bar.
- Slides second rope retaining device onto the bar.
- Installs the rope keeper pin into the fast-rope bar.

c. **Rigging of Fast Rope in Other Aircraft.** CH-47, CH-46, RH-53, HH-53 use the same type of fast-rope bar only double when using the ramps (see Figure 6-6).

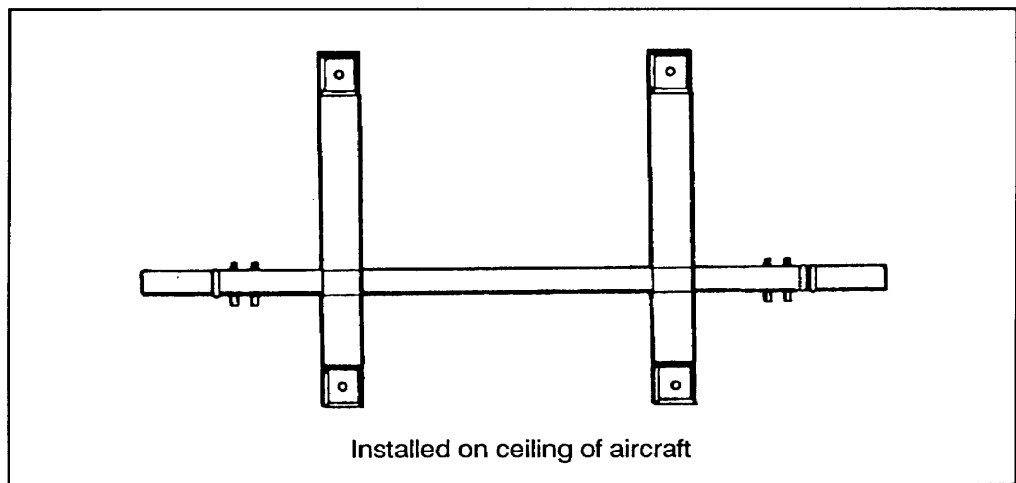

**Figure 6-6. Double fast-rope bar.**



d. **Consideration for Safety.** While in flight, the normal procedures for in-flight emergencies are used (see paragraph 6-2). Conducting fast-rope operations is dangerous. Doing so with heavy loads requires LRS teams to be proficient in fast-rope operations. While executing the fast-rope operations, the following procedures are used.

- (1) Aircraft emergency.
  - Stop stick (cease fast-rope operations).
  - Ensure ropers are clear.
  - Take appropriate action.
- (2) Unsafe drift or premature lift-off.
  - Lock in.
  - Stop stick.
  - Get back on target.
  - Continue operations.

- (3) Hung rope.
  - Ensure ropers are clear.
  - Descend aircraft.
  - Release rope - use ground personnel to untangle rope from obstacle.
- (4) No communications.
  - Use hand signal to “stop stick” (clenched fist touching the chest).
  - Use hand signal for “ropers” (pointing a finger toward the exit).
  - Use hand signal for aircraft movement (open palm moved and faced in the direction required).
  - Use hand signal to stop aircraft movement (clenched fist).

NOTE: The last minute before “Ropes away” is a critical time. With the doors open and the safety line is the only thing to hold on to, any sudden aircraft movement may throw personnel out of the aircraft.

**e. Fast-Rope Master Duties.**

- (1) Brief members of his team and aircrew.
- (2) Inspect team members for appropriate equipment configuration and conduct briefback. (Work gloves, all equipment tied down on personnel. Also inspection of aircraft rigging.)
- (3) Install the fast rope in the aircraft and conduct safety checks.
- (4) Relay 10-minute, 6-minute, 1-minute, and 30-second time warnings to team members.
- (5) Break chemical lights, if required. (Chemical lights are taped with one at anchor point, one at the bottom end of the rope and another five feet higher.)
- (6) Ensure rope is properly configured for deployment (back-fed to prevent tangles).
- (7) Ensure team members are in order of exit before 1-minute warning.
- (8) Confirm target on final approach.
- (9) Deploy rope and ensure it is on the ground before ropers descend. (During night operations, two chemical lights taped to the bottom should be used.)

- (10) Deploy personnel using the following warnings to the pilot:
- ROPE OUT—when fast-rope master deploys the rope over the target.
  - ROPERS AWAY—when first roper exits on fast rope.
  - ROPE CLEAR—informs pilot he is clear for flight.
  - HOLD—informs pilot to hold position.
  - MOVE, LEFT (RIGHT, FORWARD, BACK).
- f. **Execution of Fast Roping.** Individual ropers must—
- Understand all aspects of the insertion and emergency procedures.
  - Ensure correct equipment configuration to prevent snagging and injuries.
  - Maintain an orderly and rapid exit formation.
  - Grasp rope firmly before exit (do not jump for the rope).
  - On exit, rotate body 90 degrees to 180 degrees to clear the aircraft.
  - Descend down the rope, controlling the speed and breaking two-thirds of the distance down to avoid landing on another individual.
  - Upon landing, be prepared to execute a good parachute landing fall, and move rapidly away from the rope(s), avoid the front of the aircraft.
  - Consider individual safety:
    - Each individual is responsible for identifying hazardous situations and inform the fast-rope master.
    - During the fast roping, night vision goggles will not be used by fast ropers, due to limited depth perception and a tunnel-vision effect.
    - During descent, ropers must maintain visual contact with lower ropers and watch for obstructions.
    - Individual ropers will lock in during emergencies, by wrapping the rope around one leg one or two times and standing on the fast rope with the other foot.

### **6-8. ARMY AVIATION AND AIR ASSAULT**

Army aviation can increase LRSU mobility as well as flexibility. Once inserted behind enemy lines, LRS teams gather human intelligence that can

lead to decisive offensive action. This action can be quickly undertaken to exploit the success of LRS teams intelligence gathering capabilities.

a. **Air Assault.** Successful air assault execution is based on a careful analysis of METT-T and detailed, precise, reverse planning. Five basic plans that comprise the reverse planning sequence are developed for each air assault operation. They are—

- The ground tactical plan.
- The landing plan.
- The air movement plan.
- The loading plan.
- The staging plan.

These plans are normally coordinated and developed by the detachment or company headquarters to make the best use of available time. If time is limited, planning steps may be compressed or conducted concurrently; detailed, written plans and orders may be supplemented by SOPs or lessons learned in earlier training. Previous training and the development of SOPs cannot be overemphasized. Doctrinally, the battalion is the lowest level that has enough personnel to plan, coordinate, and control an air assault operation. When company-size or lower operations are conducted, the bulk of the planning takes place at battalion or higher headquarters.

(1) *Ground tactical plan.* The foundation of a successful air assault operation is the commander's ground tactical plan. All additional plans must support this plan. The plan specifies actions in the objective area to accomplish the mission and address subsequent operations.

(2) *Landing plan.* The landing plan must support the ground tactical plan. This plan sequences elements into the area of operations. They ensure that units arrive at the designated locations at the time and are prepared to execute the ground tactical plan.

(3) *Air movement plan.* The air movement plan is based on the ground tactical and landing plans. It specifies the schedule and provides instructions for air movement of soldiers, equipment, and supplies from PZs to LZs.

(4) *Loading plan.* The loading plan is based on the air movement plan. It ensures that soldiers, equipment, and supplies are loaded on the correct aircraft. Unit integrity is maintained when aircraft loads are planned. Cross-loading may be necessary to ensure survivability of command and control assets and the mix of weapons arriving at LZ ready to fight. The platoon or team leader should always ensure that the aircraft is loaded so that dismounting soldiers react promptly and contribute to mission accomplishment.



(5) *Staging plan.* The staging plan is based on the loading plan and prescribes the arrival of ground units (soldiers, equipment, and supplies) at the PZ in the order of movement.

b. **PZ and LZ Criteria.** PZ and LZ size requirements depend on the type and number of helicopters and the minimum acceptable distance between aircraft. Each aircraft should be provided a circular landing point separated from other aircraft and free of obstacles. Minimum recommended landing point sizes (diameter of circle in meters) are—

- Observation helicopters - 25 meters.
- UH-1, AH-1 -35 meters.
- UH-60, AH-64 -50 meters.
- Cargo helicopters -80 meters.

(1) *Surface conditions.* Surface conditions in the PZ and LZ should not conceal the touchdown point or create hazards to landing; that is, sand, blowing dust, snow. The surface of the zone should be free of obstacles that could damage landing aircraft (tree stumps, large rocks). It must be firm enough to support the traffic. Drainage should be adequate for rainfall runoff. If the surface is contaminated (chemical or radiological) to an unacceptable degree, it may preclude use of the area. If part of the area is unsatisfactory for any reason, that part is not used.

(2) *Ground slope - landing.* As a guide, if the ground slope is 0 to 6 percent, land upslope; if the slope is 7 to 15 percent, land sideslope; over 15 percent, no touchdown (aircraft may hover to drop off or pick up personnel and or equipment).

(3) *Obstacles.* For planning purposes, an obstacle clearance ratio of 10 to 1 is used on the approach and departure ends of the PZ and LZ. That is, a landing point requires 100 feet of horizontal clearance if a helicopter must approach or depart directly over a 10-foot tall tree. All obstacles within the PZ and LZ are marked with red lights at night (turned on only when PZ or LZ is in use), or red panels during the day. The markings are not used if they cause the position to be seen by the enemy.

(4) *Approach and departure.* The terrain surrounding a possible PZ or LZ is analyzed for air traffic patterns. In a tactical situation, constantly approaching the PZ or LZ over the same ground should be avoided. Still, there are only so many ways to get into an area. Approaches should be free of obstacles; landings should be made into the wind, but away from the sun. Ideally approach and departure are made along axis of the LZ over the lowest obstacle, and into the wind.

(5) *Loads.* When a helicopter is loaded to near maximum lift capacity, it requires longer distances to liftoff and land. (It cannot ascend or descend

vertically). The greater the load (near or at maximum), the larger the PZ and LZ must be to accommodate a flight.

c. **Selection and Marking of PZs and LZs.** Small unit leaders should be skilled in selecting and marking of PZs and LZs.

(1) During the day, a ground guide marks the PZ or LZ for the lead aircraft by holding an M16A2 rifle over his head, by displaying a folded VS-17 panel chest-high, or by other identifiable means. At night, the code letter inverted "Y" is used to mark the landing point of the lead aircraft. Chemical light sticks or beanbag lights may be used to maintain light discipline (Figure 6-7).

(2) When more than one aircraft is landing in the same PZ or LZ, there will be an additional light for each aircraft. For observation, utility and attack aircraft, each additional aircraft landing point is marked with a single light placed at the exact point that each aircraft is to land. For cargo aircraft (CH-47, CH-53, CH-54), each additional landing point is marked with two lights. The two lights are placed 10 meters apart and aligned in the aircraft direction of flight.

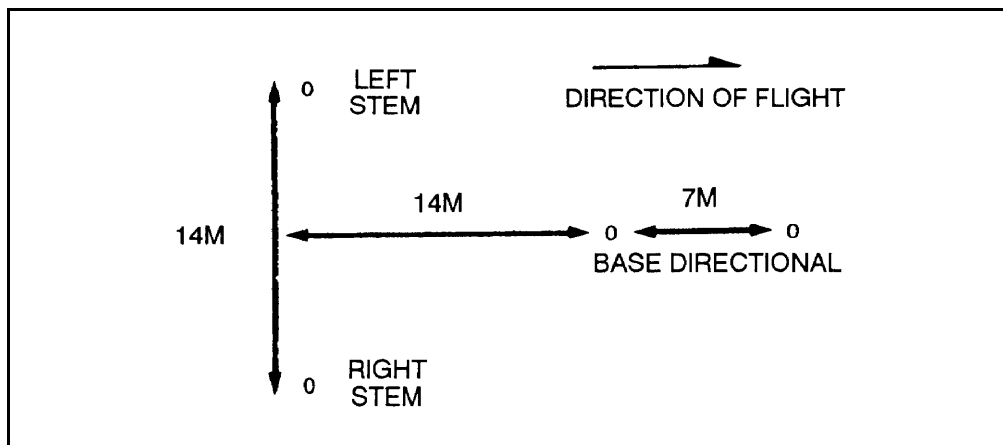

**Figure 6-7. Inverted Y.**

d. **Obstacles.** These include any obstruction which might interfere with aircraft operation on the ground (trees, stumps, rocks). During daylight, the aircrew is responsible for avoiding obstacles on the PZ or LZ. For night and limited visibility operations, all obstacles are marked with red lights. The following criteria is used in marking obstacles:

(1) When the obstacle is on the aircraft approach route, both the near side and far sides of the obstacle are marked.

(2) If the obstacle is on the aircraft departure route, the near side of the obstacle is marked.

(3) If the obstacle protrudes into the PZ or LZ, but is not on the flight route of the aircraft, the near side of the obstacle is marked.

(4) Large obstacles on the approach route are marked by circling the obstacle with red lights.

(5) Approaching aircraft are controlled by the use of arm-and-hand signals to transmit guidance for landing. The signalman is positioned to the right front of the aircraft where he can best be seen by the pilot. Signals at night are given by using lighted batons or by flashlights in each hand. When using flashlights, the signalman must avoid blinding the pilot. Batons and flashlights remain lit at all times when signaling. The speed of the arm movement indicates the desired speed of aircraft compliance with the signal.

e. **PZ Operations.** Before arrival of the aircraft, the PZ must be secured. PZ control party positioned and the soldiers and equipment positioned in the LRS team PZ or ORP. When occupying the team PZ or ORP, the team leader should accomplish the following:

(1) Maintain all-round security of the PZ or ORP.

(2) Maintain communications (ground-to-air purposes).

(3) Brief marking team for exact aircraft landing point and check their equipment.

(4) Establish priority of loading for each soldier.

(5) If time permits a detailed plan, use and incorporate a coordination checklist (see example in Figure 6-8, page 6-33). Apply the information from the checklist to the aerial movement annex to the OPORD (See Appendix J for example OPORD with annexes).

(6) UH-60 loading sequence (Figure 6-9, page 6-35). The team leader and pilot maintain communications by using the aircraft's troop commander's handset or by requesting a separate headset.

(a) Team leader initiates movement once aircraft has landed. The far-side and near-side teams move to the aircraft, in file, with the team leader always leading the near-side group.

(b) Team leaders should-

- Ensure all personnel wear and carry rucksacks on the aircraft.

- Notify the crew chief when all team members are on board and ready for liftoff.

- Ensure all personnel buckle up as soon as they are in their assigned seats.

<b>I. GENERAL.</b>		
1. Mission:		
2. Units Participating:		
3. Threat Forces:		
4. Weather: Ceiling	Visibility	Wind speed
Wind direction	Temperature	
Sunrise	Sunset	
Moonrise	Moonset	Illumination
Prevalent weather condition		
<b>II. FLIGHT DATA</b>		
1. Troop Load:		
2. Equipment Load:		
3. Pickup Zone:	Time:	
4. Lift-Off:		
5. Alternate Pickup Zone:	Time:	
6. Landing Zone:	Time:	
7. Alternate Landing Zone:	Time:	
8. Deception Measures:		
9. Penetration Points:		
10. Flight Route to Objective:		
11. Flight Route from Objective:		
12. Alternate Routes to Objective:		
13. Alternate Routes from Objective:		
14. Checkpoints and Description:		
15. Aircraft Linkup Point:		
16. Air Control Points:		
17. Downed Aviator Pickup Points:		
18. Abort Criteria:		
19. Enemy Air Defense Locations:		
20. Suppression of Enemy Air Defense Measures:		
A.		
B.		
C.		
D.		
21. Gun-Target Lines:		
22. Prominent Features on Routes or Landing Zone:		
A.		
B.		
C.		
D.		
23. Aircraft Formation:		
24. Aircraft Speed:		
25. Aircraft Altitude:		
26. Aircraft Crank Time:		
27. Pathfinders:		

Figure 6-8. Example coordination checklist.

28. Extraction Time:		
29. Extraction Pickup Zone:		
30. Alternate Extraction Pickup Zone:		
<b>III. TACTICAL PLAN</b>		
1. Ground Tactical Plan:		
2. Fire Support Plan:		
3. Air Cavalry:		
4. Attack Helicopter:		
5. Lift Aircraft:		
6. Tactical Air:		
7. Ordnance:		
8. Hand-Off Point:		
9. Aircraft Security Force:		
<b>IV. COMMUNICATIONS</b>	<b>FREQUENCY</b>	<b>CALL SIGN</b>
1. Commander:		
2. Pickup Zone Control:		
3. Pathfinders:		
4. SOI in Effect:		Time Change:
5. Challenge:		Password:
<b>V. MARKINGS</b>		
1. Panels:		
2. Strobes:		
3. Bean Bags:		
4. Pyrotechnics:		
5. Smoke:		
6. Light Gun:		
7. Flashlights with Filters:		
<b>VI. CODE WORDS</b>		
1. Clean:		
2. Secure:		
3. Hot:		
4. Cold:		
5. Abort:		
6. ALZ:		
7. APZ:		
8. Request Resupply:		
9. Fire Preparation:		
10. Request Extraction:		
<b>VII. SYNCHRONIZE WATCHES</b> Time Zone:		
<b>VIII. MISCELLANEOUS</b> Air Movement Table:		

Figure 6-8. Example coordination checklist (continued)

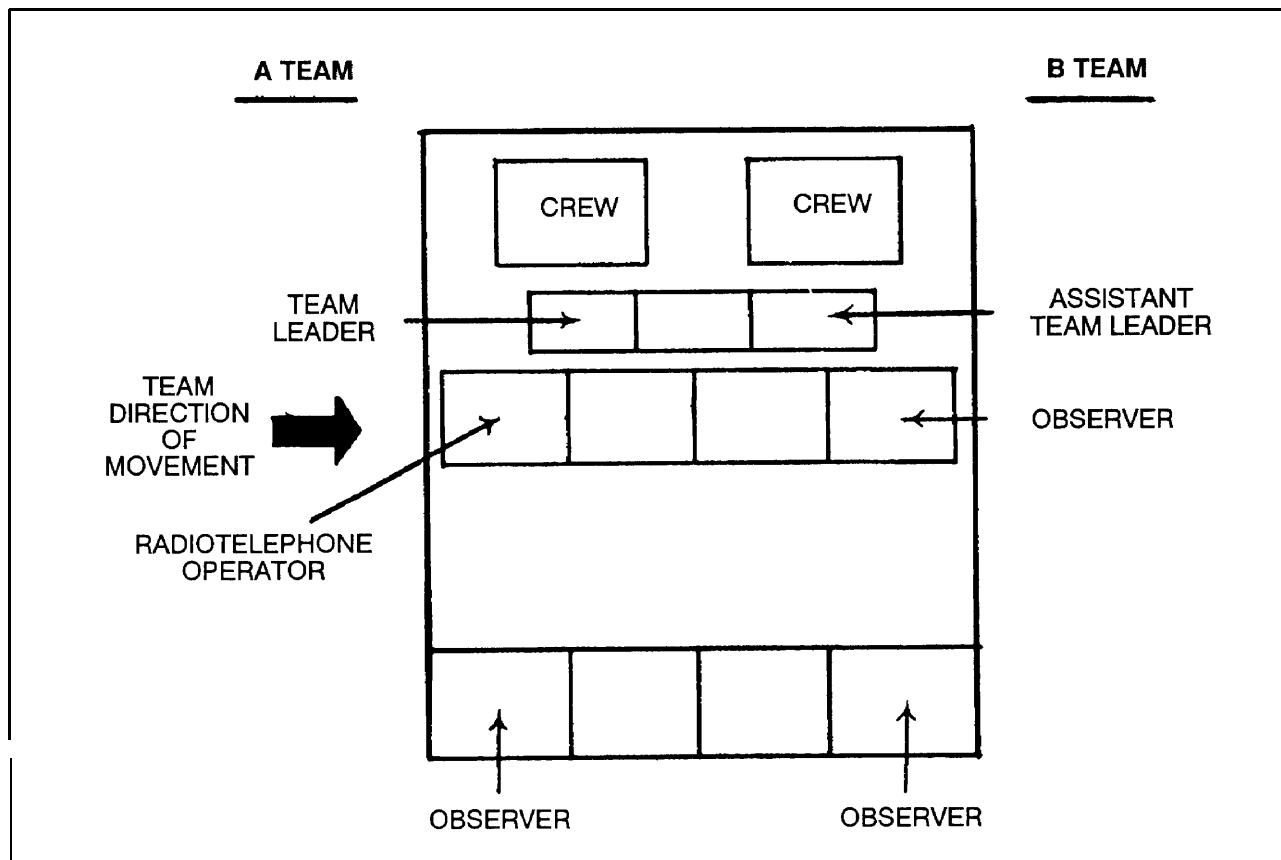

**Figure 6-9. UH-60 loading diagram.**

**f. Landing Zone Operations.** The following is a priority of actions in landing on an LZ.

(1) The team leader obtains the landing direction from the pilot; then informs all team members before landing. This aids in orientation to the LZ, particularly during night operations.

(2) Unloading of the aircraft does not begin until directed by the crew chief or pilot.

(3) Once the aircraft has landed, personnel unbuckle their seat belts and exit the aircraft as fast as possible with all equipment.

(4) Individuals move 15 to 20 meters out from the side of the aircraft and assume the prone position facing away from the aircraft, weapons at ready position, until the aircraft has departed the LZ.

(5) The LRS team should then move to an assembly area out of sight and sound of the LZ (500 meters) long enough to adjust their senses to the surrounding environment and to verify the location of the LZ using map checks or global positioning systems. After unloading from the aircraft, the

team leader moves the team to a predetermined location, using moving techniques appropriate to the terrain. Once at the concealed assembly point, the team leader makes a quick count of personnel and equipment, and then proceeds with the mission.

(6) Soldiers maneuver off the LZ to the closest side offering cover and concealment.

(7) The team may elect to have the aircraft wait in the vicinity for 5 to 10 minutes to allow for the hasty extraction of the team if compromised.

(8) If soldiers are engaged by nearby enemy positions, they treat it as a near ambush by immediately returning fire. Soldiers who consider themselves in the kill zone may assault the enemy position(s) or attempt to leave the kill zone. Soldiers not in the kill zone provide supporting fire to support the movement of soldiers in the kill zone.

(9) The LRS team leader calls for close air support, if it is available.

(10) Once disengaged from the enemy force, the team leader moves the unit to a covered and concealed position, accounts for personnel and equipment, and assesses the situation as to whether or not the unit can continue its mission.

(11) The team leader may elect to call for an emergency extraction using the SPIES extraction method.

(a) The team leader gives a direction and distance to the emergency extract site from the insertion site.

(b) As the aircraft approaches, the team leader initiates a directional signal; for example, pen gun flare, strobe light with a directional funnel attached.

(c) Ground to air gives the aircraft a clock direction and distance from the aircraft to the team's location and has pilot identify the signal initiated by team.

(d) Once the aircraft confirms the signal, the aircraft forms its approach and receives assistance from the team leader.

g. Command and Control. A member of the LRSU headquarters should fly with the team on insertions and extractions. This headquarters representation and emphasis to the criticality of the air mission and can assist with navigation and other key duties as dictated by the unit SOP.

### **Section III. AIRBORNE OPERATIONS**

Air insertion is the fastest way to infiltrate. LRS teams and equipment may be delivered by parachute, by static-line, or by free-fall techniques. Units must consider the following during planning:

- Suppress air defense along the infiltration corridor.
- Determine if enemy air defense artillery is within artillery or naval gunfire range.
- Coordinate with the transporting unit.
- Consider the chance of inflight emergencies.
- Use adverse weather aerial delivery system during limited visibility or adverse weather.
- Dispose of parachutes once assembled.

#### **6-9. LANDING PLAN**

The operation should be planned using the reverse planning sequence. The ground tactical plan is the driving force for other plans. The landing plan includes—

- Place of delivery.
- Time of delivery.
- Assembly area.
- Method of delivery (type of parachutes).
- Sequence of delivery. Team may be transported on an aircraft with personnel dropping on a different DZ. Load in order of the sequence of drops.

#### **6-10. AIR MOVEMENT PLAN**

The air movement plan includes the manifest; load plan; flight routes, inflight checkpoints; flight times; load time (50 minutes); station time (35 minutes); takeoff time; and time of target.

#### **6-11 MARSHALLING PLAN**

The jump master gives his briefings. The team conducts sustained airborne training. All joint tactical and support planning is conducted. The LRS team, equipment, and supplies are moved to departure airfield. Leader must know how the team will be transported to airfield, where the team links up with transportation, and when the team needs to be at a specified location.

### **Section IV. STAY-BEHIND OPERATIONS**

The stay-behind technique facilitates operation behind enemy lines. The team allows itself to be passed by the enemy so as to perform a specific mission.



### **6-12. PLANNING**

Use of stay-behind operations is often the most advantageous means of infiltration for an LRS team when friendly forces anticipate enemy offensive and friendly defensive operations. Stay-behind can also be used effectively when friendly forces are conducting limited offensive or reconnaissance operations. In both cases, the forward friendly unit escorts the LRS team to the area of operations and provides security for site preparation. Use of a subsurface hide site also allows the LRS team to stock extensive supplies, which allows the team to operate for an extended period.

### **6-13. SITE PREPARATION**

Because the enemy is expected to overrun and occupy the LRS team area of operations, a well-prepared subsurface site is essential. Normally, an LRS team does not have the capability to construct the site without engineer support. (See Appendix F for selection, construction, and considerations for a subsurface site.)

## **Section V. VEHICLE OPERATIONS**

A vehicle is used to move an LRS team from a planning area to a point of departure in a secure area. The team normally dismounts at the forward line of own troops, makes final preparations, and conducts a forward passage of lines. Vehicles are also used to move the team to the area of operations.

### **6-14. PLANNING**

Extensive intelligence on enemy unit locations is necessary for route planning. Fire support must be available to assist the team during movement. Ground surveillance radar can assist the LRS team in avoiding enemy units. Tactical communication intercept systems are tasked to provide early warning to the LRS team along the infiltration route. Radar detection systems can provide early warning to the LRS team for the use of enemy ground surveillance radar.

### **6-15. LRS TEAM PLANNING**

At a minimum, the LRS team leader prepares the following plans and actions for vehicle movement.

- Primary and alternate routes with checkpoints and indirect fire target reference points.
- Plans for the type of vehicle to be used for infiltration.

- Ensures there are at least two layers of sandbags on the floor of the vehicle.
- Assigns team members sector of fire with air guards.
- Plans and rehearses contact drills used with the vehicle.
- Assists the driver in route selection during movement.
- As the vehicle commander, the team leader is responsible for navigation.
- Ensures the vehicle is serviceable and safe.
- Knows the time and location for vehicle linkup.
- Briefs the vehicle driver and crew on the vehicle movement order.

## **Section VI. FOOT MOVEMENT OPERATIONS**

Foot movement into the area of operations is normally used from a point of departure in a secure area. Foot movement can also be used in conjunction with vehicle movement. Foot movement is most often conducted during limited visibility or in conjunction with normal friendly unit activity such as security patrols.

### **6-16. PLANNING**

Extensive intelligence on enemy unit locations is necessary for route planning. Fire support must be available to assist the team during movement. Ground surveillance radar can assist the LRS team in avoiding enemy units. Tactical communication intercept systems are tasked to provide early warning to the LRS team along the infiltration route. Radar detection systems can provide early warning to the LRS team for the use of enemy ground surveillance radar.

### **6-17. MOVEMENT**

Route selection should take advantage of rugged and normally inaccessible terrain to decrease the chance of enemy detection. Movement distances for the LRS team are short and should exceed more than several days because of the terrain and the equipment loads. This also necessitates resupply as a priority once the team arrives in the area of operations.

## APPENDIX A

**PERSONNEL RECRUITMENT AND SELECTION**

*The LRSU mission is a demanding one. Essentially, the LRSU mission is nonconventional while working in a conventional environment. Due to the complexity of the mission and the demands on the soldiers, recruitment and selection of potential LRSU soldiers is one of the unit commander's most important duties. He must select soldiers who are mature, physically fit, mentally strong and can work closely within a small group, but also can think and act independently. This appendix provides guidance to corps and division staffs and commanders in recruiting and selecting prospective LRSU soldiers.*

**A-1. CORPS AND DIVISION G1**

LRSU commanders need the cooperation of the G1 in allowing prospective unit soldiers to be attached for 30 to 60 days. During this time, the LRSU evaluates the soldier. At the end of this time, the G1 issues assignment orders to the LRSU or assigns the soldier to another unit. The commander and G1 agree on the standards. The LRSU commander must justify why the soldier failed to meet the standards.

**A-2. COMMANDERS**

The LRSU designs a recruitment and selection program that satisfies the personnel needs of the unit. It is approved by the battalion commander in cooperation with the G1.

a. In recruiting prospective LRSU soldiers, the following screening standards are desirable:

- Airborne qualified (specialist four or corporal and below).
- Airborne and ranger qualified (sergeant and above).
- GT score of 110 or above.
- Must agree to volunteer for airborne and ranger schools (if applicable).
- Meet US Army height and weight or body fat standards.
- No prior disciplinary problems.

- No history of drug or alcohol abuse.
- Graduate One-Station Unit Training without waivers.
- Have at least two years of retainability in the unit.

b. While a prospective soldier is attached to the LRSU, he should meet the following minimum standards:

- Pass the Army Physical Fitness Test (ranger school standards).
- Pass the Combat Water Survival Test.
- Complete a 5-mile run within 40 minutes.
- Complete a 12-mile road march while carrying 35 pounds within 3 hours.
- Pass a written land navigation test.
- Complete a day and night land navigation practical exercise.
- Demonstrate proficiency in basic LRSU team skills (operation of HF radios, burst devices, and construction of antennas; basic vehicle identification; as a team member conducting operations).
- Pass a comprehensive examination by the unit selection review board.

## APPENDIX B

**LONG-RANGE SURVEILLANCE RECONNAISSANCE**

*Surveillance is the primary mission of long-range surveillance teams. However they can conduct limited reconnaissance missions primarily within the human intelligence realm and within the doctrinally stated LRSU operational area. A reconnaissance mission significantly increases a team's vulnerability and, thus, chances of compromise. The mobility of a team is limited to foot movement and with the typical loads that an LRS team carries, the size of the area they can reconnoiter is greatly reduced. Bridge and route reconnaissance with report formats are included in this appendix to provide LRS teams with the information on they need if they are tasked to perform one of these missions. LRS teams are not equipped or staffed for these type missions nor is it their primary function; however, they must be prepared to conduct limited active reconnaissance. Improvements in the areas of rations, water purification, and communication equipment will have a direct affect on these missions in the future.*

**B-1. AREA RECONNAISSANCE**

Area reconnaissance is used to obtain detailed information about all routes, obstacles, and enemy forces in a defined area. The team leader organizes his team to conduct the reconnaissance in one of two ways. Depending on the terrain and time, he may either use single or multiple separate reconnaissance and security elements. (Figure B-1, page B-3.)

a. Reconnaissance and security teams may be employed in any size reconnaissance patrol. When conducting reconnaissance missions in team-size units, the team may be organized in many ways.

(1) One 2- to 3-man reconnaissance and security team conducts the reconnaissance. The remainder of the team stays at the release point and establishes a hide site.

(2) Two reconnaissance and security teams reconnoiter a separate portion of the objective, and then link up at a designated linkup point.

(3) One reconnaissance and security team, with one security team that will follow the reconnaissance and security team (for example, about 50 meters back), acts as a quick-reaction force. The entire team departs the objective area when the reconnaissance is complete.

b. In a reconnaissance and security team, the reconnaissance can be done by one or two individuals; the rest of the element provides security. The team leader controls this movement with arm-and-hand signals. The number of soldiers in a reconnaissance and security team may vary depending on the mission. Usually, three soldiers are required for an adequate

reconnaissance and still provide the required security. The information used may vary according to the terrain. The most important planning consideration is that each member of the reconnaissance and security team knows the sector or area for which he is responsible.

c. Once the team leader organizes his team, the objective is reconnoitered by using one of the following techniques.

(1) *Long-range observation and surveillance.* Long-range observation and surveillance is the observation of an objective from a point (an observation post). It must be far enough from the objective to be outside enemy small-arms weapons range and local security measures. This technique can be used whenever METT-T allows the information to be gathered from a distance. It is the most desirable method for executing an area reconnaissance, because the team does not approach close enough to be detected. Also, this prevents the team's no-fire area from overlapping the objective area. When information cannot be gathered from one observation post, a series of observation posts to be occupied by one reconnaissance team may be used. Observation posts are used that have cover and concealment. They should have a good view of the objective. Routes between and from observation posts to the hide site or release point should have cover and concealment.

(2) *Short-range observation and surveillance.* Short-range observation and surveillance is the observation of an objective from a place that is within the range of enemy small-arms weapons fire and local security measures.

(a) Short-range observation is used when METT-T requires close approach to the objective to gain information.

(b) Short-range observation and surveillance may be from observation posts, but usually the reconnaissance teams must move near the objective before they can find a position from which to observe. In some cases, the reconnaissance teams may gather information by listening even though they cannot see the enemy.

(c) Short-range observation increases the chance the team will be detected. The enemy may employ anti-intrusion devices and patrols close to their key installations. Inclement weather may reduce the sounds of the reconnaissance team's movement and limited visibility favors short-range observation. When short-range observation is necessary, the teams use every measure possible (both passive and active) to avoid detection.

d. To reconnoiter a road, the team leader selects multiple vantage points or observation posts along the road. The reconnaissance element, as organized by the team leader, reconnoiters bridges, defiles, bends in the road, and built-up areas. The reconnaissance element reports the condition, trafficability, and

width of the road; evidence of the enemy or obstacles; bridge and ford locations and conditions; and tunnel or underpass locations and dimensions.

e. To reconnoiter a wood line, the reconnaissance element (as organized by the team leader) uses concealed routes and stealth to reach the wood line and avoids contact. It checks for evidence of enemy activity such as tracks, litter, old fighting positions, mines, booby traps, and obstacles. It determines if the woods are trafficable and checks all positions from which the enemy could observe and fire on friendly elements in open areas and reports its findings.

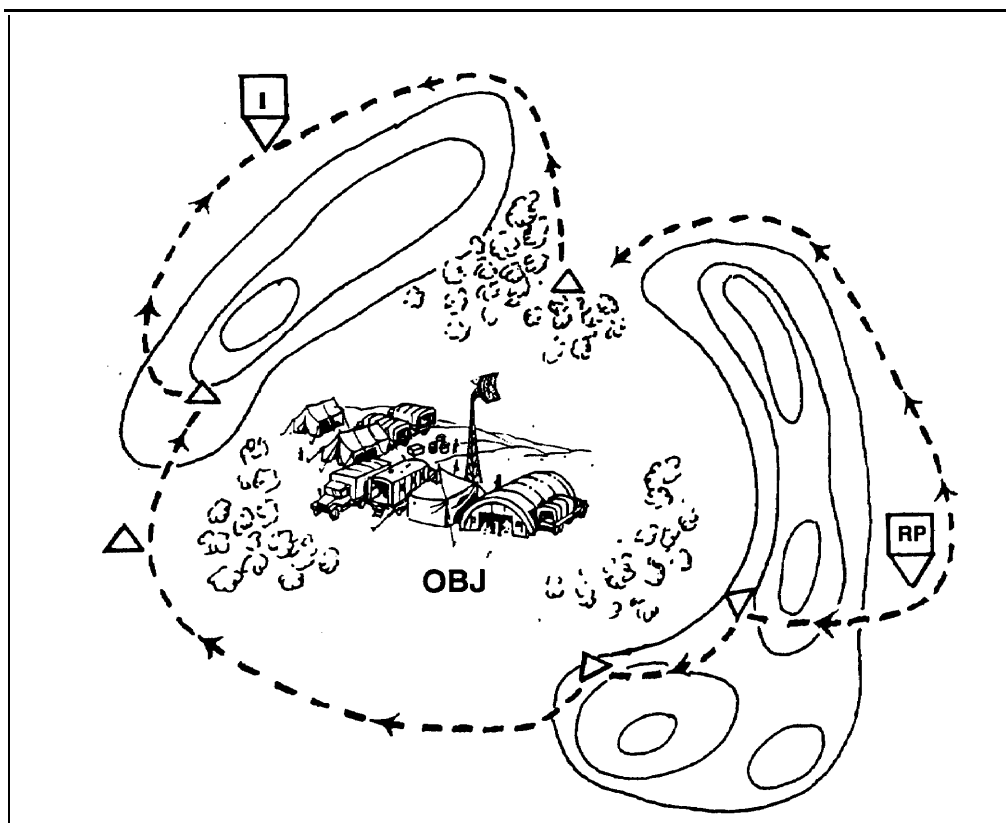

**Figure B-1. Reconnaissance and security elements.**

## **B-2. ZONE RECONNAISSANCE**

A zone reconnaissance is used when the enemy's location is in doubt or if it is best to locate suitable routes or determine conditions of cross-country trafficability. The team obtains detailed information about routes, obstacles, key terrain, and enemy activities in a zone established by lateral boundaries. The team may elect to use the fan method, converging-routes method, or successive-sectors method.

a. **Fan Method.** The team leader selects a series of ORPs throughout the zone. When the team arrives at the first ORP, it halts and establishes security. The team leader confirms the team's location. He then selects reconnaissance routes to and from the ORP. The routes form a fan-shaped pattern around the ORP (Figure B-2). The routes must overlap to ensure that the entire area has been reconnoitered. Once the routes have been selected, the team leader sends out reconnaissance elements. He keeps a small reserve in the ORP. (For example, if the team has three reconnaissance elements, only two are sent out. The other one is kept as a reserve.) The team leader also sends the elements out on adjacent routes. This prevents the team from making contact in two different directions. After the area (fan) has been reconnoitered, the information is reported. The team then moves to the next ORP. The action is repeated at each successive ORP.

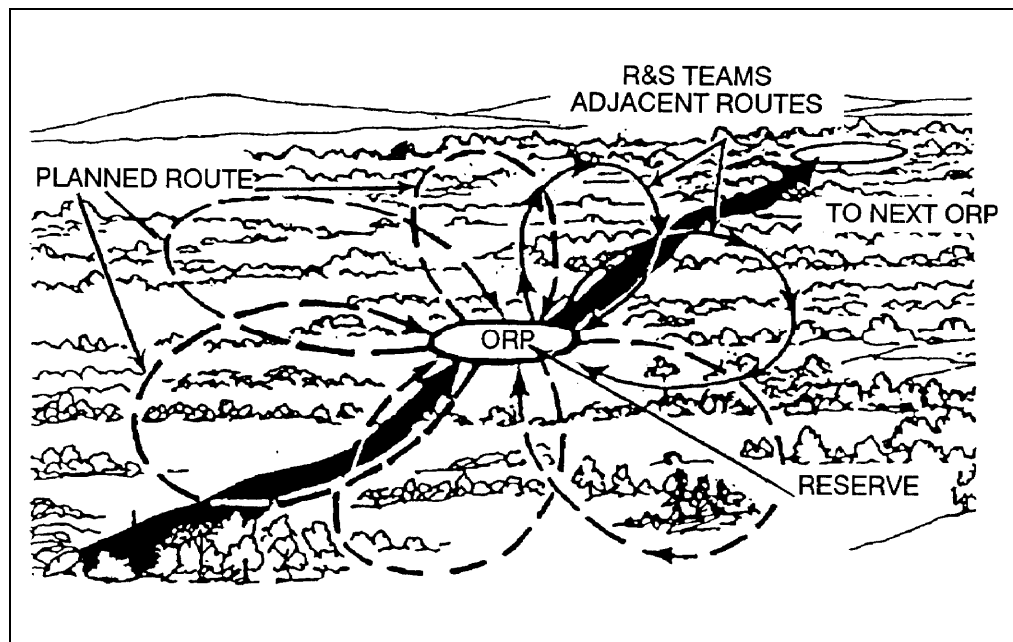
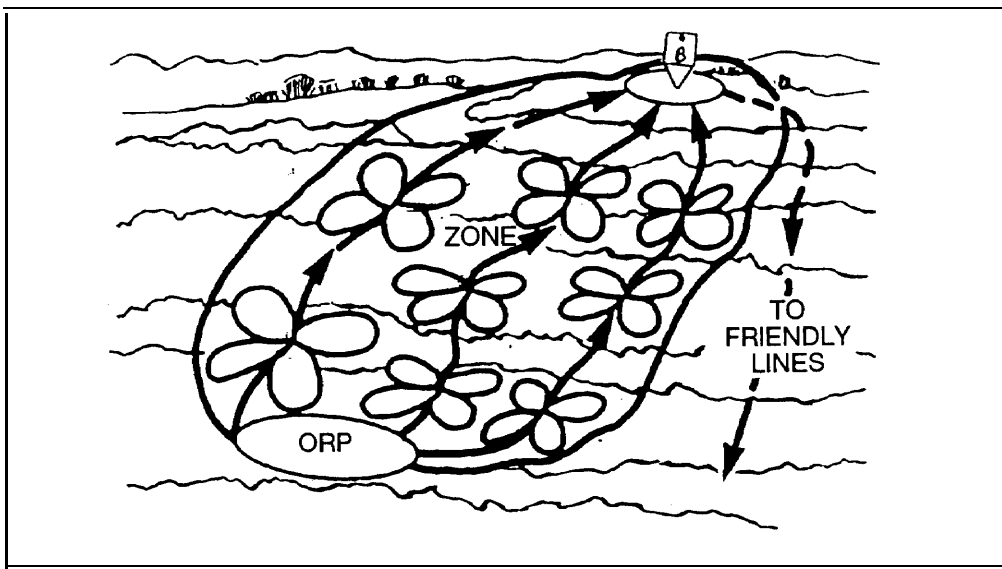

Figure B-2. Fan method.

b. **Converging-Routes Method.** The team leader selects an ORP, reconnaissance routes through the zone, and then a linkup point. A subelement is sent out on each route. The team leader normally moves with the center element. The subunits normally reconnoiter their routes by using the fan method. The entire team links up at the linkup point at the designated time. (Figure B-3.)





**Figure B-3. Converging-routes method.**

**c. Successive-Sector Method.** This method is a continuation of the converging-routes method. The team leader selects an ORP, a series of reconnaissance routes, and linkup points. The actions of the team from each ORP to each linkup point are the same as in the converging-routes method. (Each linkup point becomes the ORP for the next phase.) When the team links up, the team leader again designates reconnaissance routes, a linkup time, and the next linkup point. This action continues until the entire zone has been reconnoitered. (Figure B-4.) Once the reconnaissance is completed, the team returns to friendly lines.

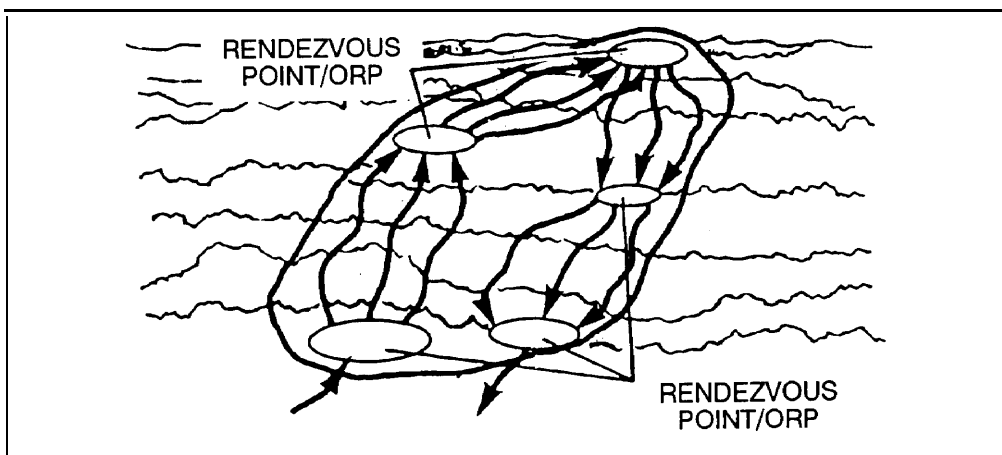

**Figure B-4. Successive-sector method.**

**B-3. ROUTE RECONNAISSANCE**

Route reconnaissance obtains information about enemy activity, obstacles, route conditions, and critical terrain features along a specific route. It is unlikely that a team will be able to obtain precise measurements of road curves, widths, heights of underpasses, and dimensions of tunnels. If possible, they report types of vehicles that are using the roads and entering or exiting the tunnels. Intelligence can then estimate widths, weight limits of roads, heights, and widths of tunnels and heights of underpasses. Figure B-5 illustrates the information a team is required to report on a route reconnaissance. Figure B-6, page B-8, shows various report formats. (All report formats in this manual are in FM 5-36.) Possible information requirements for an LRS route reconnaissance include—

- The available space in which a force can maneuver without being forced to bunch up due to obstacles (reported in meters). The size of trees and the density of forests are reported due to the effect on vehicle movement.
- The location of all obstacles and the location of available bypass.
- Any enemy forces that can influence movement along the route.
- The observation and fields of fire along the route and adjacent terrain.
- The locations along the route that provide good cover and concealment.
- Trafficability along the route.
- Landing and pickup zones along the route.
- Any bridges by construction and type, estimated dimensions of the bridge, and any vehicles crossing the bridge. This will enable intelligence to estimate load classification.

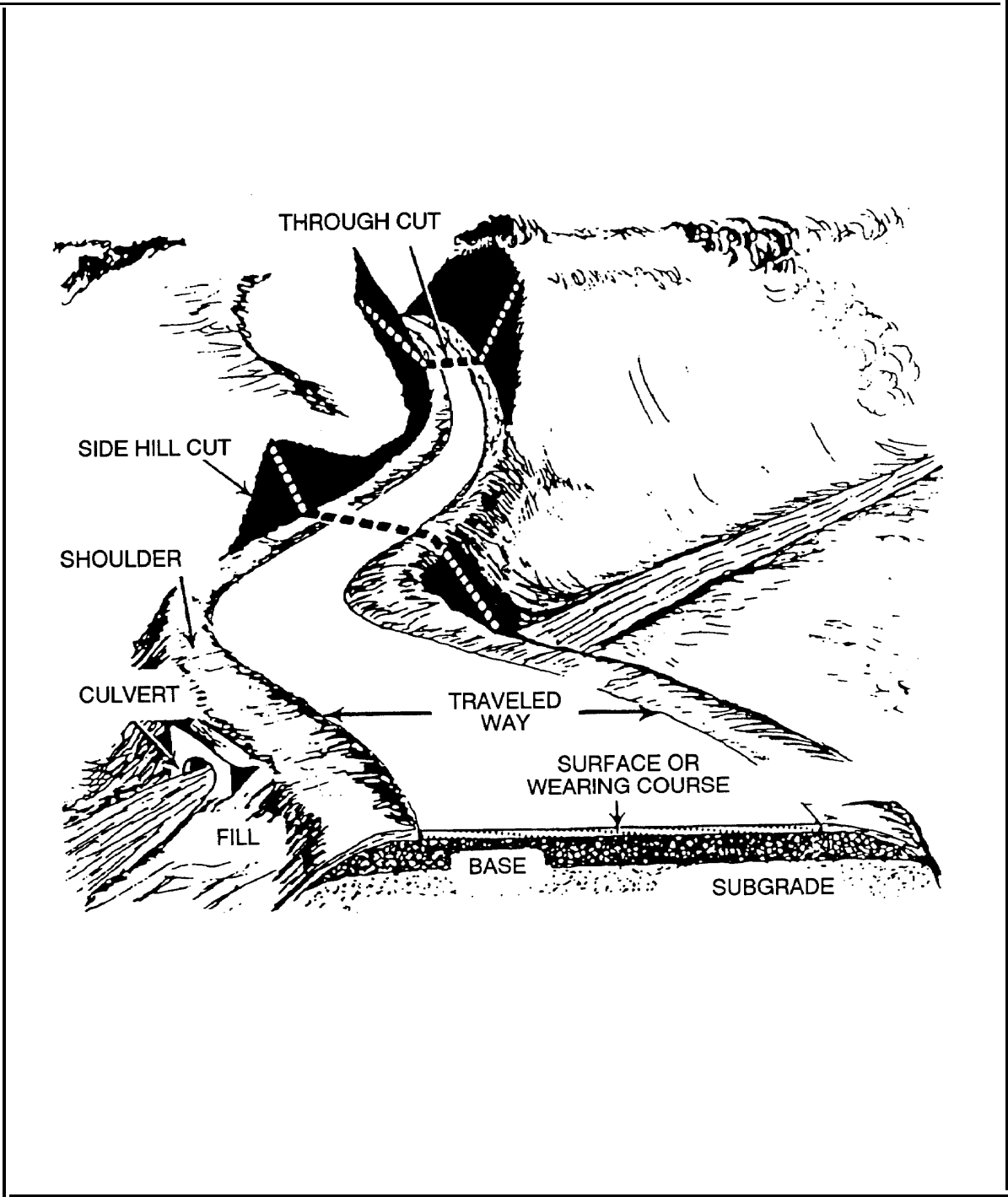

Figure B-5. Route reconnaissance information.

AIRFIELD REPORT		TERRAIN REPORT FORMAT	
LETTER DESIGNATION	EXPLANATION	LETTER DESIGNATION	EXPLANATION
A B C D E F G H I J K L	Map sheet(s). Date and time of collection of information. Location (grid references). Number of runways (length and width). Orientation of runways. Type and surface of runways. Condition of the runways. Hangars and bulk fuel storage facilities, including condition. Parking area for the aircraft. Maintenance facilities. Access by road, Any other information such as type of aircraft that could use the airfield.	A B C D E F G	Map sheet(s) and grid references. Shape of the ground (flat, rolling, hilly, mountainous). Cross-county movement. Vegetation. Concealment. Land use. Suitability of the soil for digging.
Report airfields by serial number. The appropriate letter designation must precede each category of information reported.		Report terrain areas by serial number. The appropriate letter designation must precede each category of information reported.	
FERRY SITE REPORT FORMAT		BRIDGE SITE REPORT	
LETTER DESIGNATION	EXPLANATION	LETTER DESIGNATION	EXPLANATION
A B C D E F G H I J K	Map sheet(s). Date and time information was collected, Location (UTM grid reference). Military load classification of approaches. Possibilities of concealment and cover, Width of water obstacle, Depth of water at the banks, to include tidal information. Stream velocity, Slope on bank approaches and bank conditions, Holding areas for road and water transport, Additional information such as maximum number of rafts the site can accommodate. Work required in man-hours for preparation and existing stream-crossing equipment.	A B C D E F G H I J K L M	Map sheet(s), Date and time of collection of information. Location (grid references). Width of gap at bank seats. Width at water level. Rise and fall of water level and change in wet gap width. Velocity of current, Nature of bottom. Height of near bank above water level. Height of far bank above water level. Safe bearing pressure of soil. Description of work required on approaches, near and far banks. Possible local areas for concealing bridging equipment.
Report ferries by serial number. The appropriate letter designation must precede each category of information reported.		Report bridge sites by serial number. The appropriate letter designation must precede each category of information reported.	

Figure B-6. Route reconnaissance reports.

FORD REPORT FORMAT		TUNNEL REPORT FORMAT	
LETTER DESIGNATION	EXPLANATION	LETTER DESIGNATION	EXPLANATION
A	Map sheet(s).	A	Map sheet(s).
B	Date and time information was collected.	B	Date and time information was collected.
C	Location (UTM grid coordinates and ford type).	C	Location (UTM grid coordinates).
D	Minimum width.	D	Length.
E	Maximum depth.	E	Width.
F	Stream velocity.		
G	Type of bottom.		
H	Maximum percent of slope on bank exits.		
I	Military load classification.		
J	Other information.		
Report fords by serial number. The appropriate letter designation must precede each category of information reported.			
<b>ENEMY MINEFIELD AND OR UNIDENTIFIED MINEFIELD NOT LAID BY REPORTING UNIT REPORT</b>			
LETTER DESIGNATION	EXPLANATION		
A	Map sheet(s).		
B	Date and time information was collected.		
C	Type of minefield (antitank, antipersonnel, or mixed).		
D	Grid references or minefield extremities, if known.		
E	Depth of minefield.		
f	Enemy weapons or surveillance bearing on the minefield, if any.		
G	Estimated time required to clear minefield.		
H	Estimated material and equipment required to clear minefield.		
I	Routes for bypassing the minefield, if any.		
J-Y	Grid references of lanes (entry, exit) and width of lanes in meters.		
Z	Any other information such as types of mines used, new mines, or types of booby traps.		

**Figure B-6. Route reconnaissance reports (continued).**

**B-3. BRIDGE RECONNAISSANCE**

Bridge reconnaissance is not a separate category of reconnaissance, but may be a necessary part of area, zone, or route reconnaissance. Procedures are taken to provide dimensional data to analyze the bridge structure for repairs, demolition, or military load classification. It is not likely that a team will be able to obtain precise measurements. If possible, they report the type and number of vehicles crossing bridge. Intelligence can estimate the weight limit, height, and weight of bridge. (See Figures B-7 and B-8.) (See FM 5-36 for more information.)

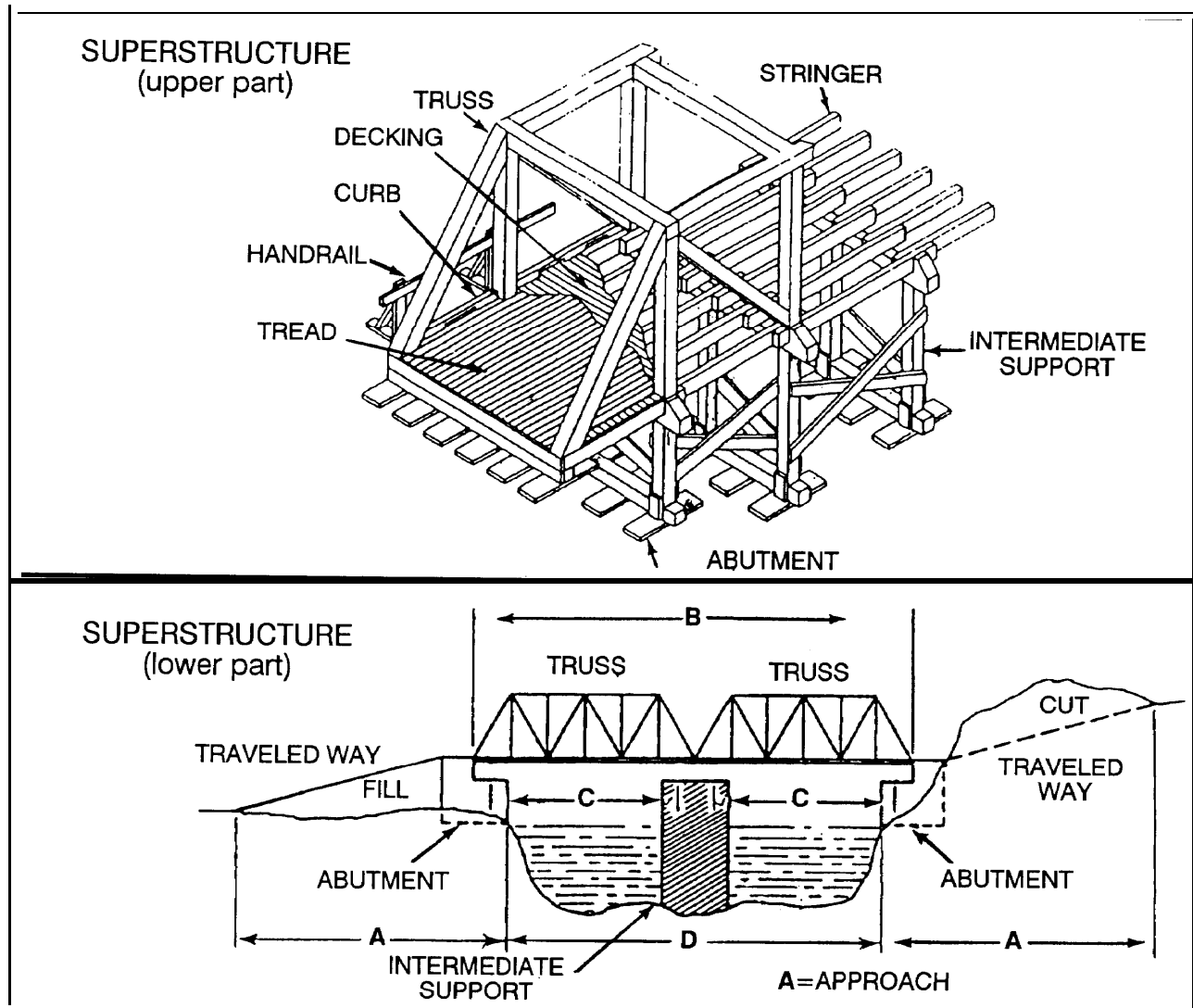

Figure B-7. Bridge parts.

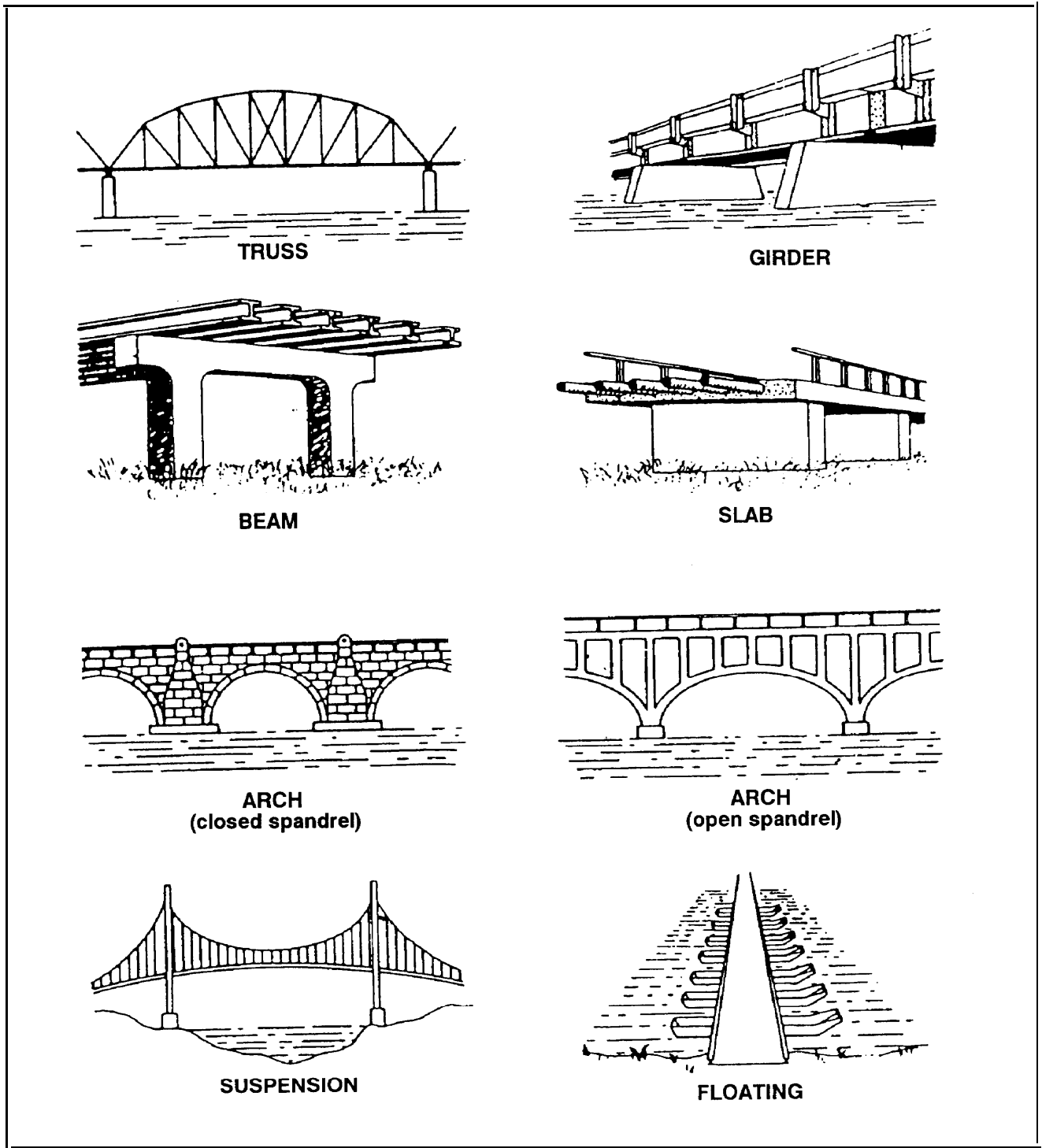

Figure B-8. Typical bridge spans.

## APPENDIX C

**GEOGRAPHIC ENVIRONMENTS**

*Combat-arms field manuals describe conditions encountered and techniques of operating in jungles, deserts, mountains, cold weather and urban areas. Teams operating in these areas are greatly affected by adverse weather and terrain conditions. Extremes in temperature, humidity, and elevation also have considerable effect on the lift capability of transporting aircraft.*

**C-1. JUNGLE OPERATIONS**

Operations in dense jungle increase the importance of LRS teams because of restricted ground and air observation, including electronic surveillance systems. Human intelligence sources can become the primary source of battlefield information in this terrain. Jungle environments are frequently characterized by dismounted operations, which offers less signature for technical collection efforts. Reconnaissance may be necessary to find the surveillance target, because detailed intelligence may not be available for preparing the mission folder (and because of the fleeting nature of the targets). The nature of these operations places a premium on LRS dismounted skills, particularly stealth, navigation, and break contact drills. Other considerations are infiltration, exfiltration, and communication. (See FM 90-5 for more information on jungle operations.)

a. **Infiltration.** Distance of penetration behind enemy lines may be shorter than for more open terrain. Dismounted, helicopter, and small boat movements are well suited for jungle terrain. All require careful planning and training. Techniques such as rappelling or FRIES may be necessary because of limited available LZs. Careful coordination with adjacent or friendly forward units is necessary for foot or boat movements to prevent fratricide.

b. **Exfiltration.** Teams may be recovered by all available means, but communication and coordination is key due to the rapidly changing nature of jungle operations. Dismounted exfiltration routes must be coordinated immediately before the teams move along them. Linkup operations with friendly forces require careful and deliberate coordination to the lowest element possible (battalion, company). The SPIES is ideally suited for picking up a team from dense vegetation.

c. **Communication.** Dense vegetation, high humidity, and frequent rainfall make HF communication difficult. The vegetation affects radio range and makes antenna erection more difficult. Radio components experience higher failure rates in wet environments.



## C-2. DESERT OPERATIONS

Effective operations in deserts require personal responsibility. To survive in the desert, LRS teams must approach each task in a systematic manner so that it becomes a habit. Weather and terrain are the primary enemies in any military operation, this threat is greatly increased in the desert (FM 90-3). The basic elements of a desert environment are—

- Intense sunlight and heat. These can quickly dehydrate the body.
- Sparse vegetation. Little or no shade can be found and no vegetation to hold the soil down in the wind.
- Mirages obscure terrain and confuse navigation.
- Sandstorm and dust storm. Strong winds usually sweep the areas from northeast to southwest. A searing sandstorm comes from the east or southeast, which impedes visibility and destroys vegetation.
- Light levels are extreme. Bright sunlight can blind soldiers temporarily, and it is often conversely as dark during night hours.
- High-mineral content deposits near the ground surface. These affect radio waves, creating dead spots for radio transmission.
- Wide temperature range. Variations of temperature between day and night can exceed 50 degrees Fahrenheit.
- Low rain fall. This lack of rain leaves few natural water sources and causes dust hazards.

a. **Individual Soldier Responsibilities.** The body requires a given amount of water for a certain level of activity, at a certain temperature. The normal body temperature is 98.6 degrees Fahrenheit. Excess sweating reduces body water content; therefore, water discipline must be enforced in an arid environment to maintain the body's fluid level.

(1) During the hottest periods of the day, soldiers should remain quiet and stay out of the sun. Excess movement causes water loss through sweating. The first measure is to get out of the sun. Soldiers should not sit directly on desert sand or rocks. The ground is 20 degrees hotter than the air. Soldiers should sit under man-made shade, if necessary.

(2) Soldiers must drink water at regular intervals to help remain cool and keep sweating reduced. Even if water supplies are low, soldiers can constantly sip water.

(a) Thirst is not a reliable guide for the body's need for water. Thirst only accommodates two-thirds of the daily requirement. Soldiers should drink at least one-half a quart of water every hour. If the temperature is over 100 degrees Fahrenheit, soldiers should drink one quart of water every hour. They should drink a quart of water with each meal. If there is not enough water, soldiers should not eat.

(b) Water can be flavored with a small amount of a thirst-quencher drink or beverage mix (such as Gatorade or Kool-Aid) to break the monotony. Soldiers should not drink this exclusively, because too much sugar can cause dehydration.

(c) Water in canteens must be changed every 24 hours. Water will go bad if the temperature exceeds 96 degrees Fahrenheit for 72 hours.

(d) Soldiers must avoid alcohol, tobacco products, and caffeine. These substances cause dehydration.

(e) Soldiers should check their urine. A lack of the need to urinate and dark-colored urine are signs of dehydration.

(f) Soldiers should use extra salt in meals, ready-to-eat, but they should not eat salt straight unless an aidman or doctor prescribes additional salt.

(3) Soldiers need at least 6 hours of sleep each day.

(4) Soldiers should be careful around equipment.

(a) Gloves should be accessible to pick up hot items.

(b) Boots and sleeping bags need to be checked for snakes, scorpions, spiders, or other creatures before using the items.

(c) Weapons should not be oiled until needed for combat. Oil attracts sand, which causes jams. To fight rust and sand, weapons must be cleaned daily.

(5) The minimum desert uniform is the desert battle dress uniform with sleeves down, floppy hat, sunglasses, and a scarf. All clothing should be worn loosely. Socks should be changed when they become wet or at least daily. Soldiers should use the buddy system to supervise each other to avoid desert-related injuries.

**b. Operational Considerations.** Leaders must consider the following in planning desert LRS operations.

(1) *Planning.*

(a) Teams cannot stay in position for more than 5 days unless there are caches of water established.

(b) Soldiers must drink 2 quarts of water an hour for 24 hours before insertion.

(c) Soldiers must carry 11 quarts of water (three 2-quart canteens and one 5-quart bladder).

(d) Soldiers must drink 7 quarts of water per day when stationary and 11 quarts when moving.

(e) Teams must test all batteries with a battery tester; battery life is reduced one-third in the heat.

(f) Teams must plan or cache an emergency resupply of water and ammunition.

(2) *Insertion.*

(a) Teams should be inserted on a salt marsh or other hard packed area to prevent dust and sand from obscuring the pilot's view.

(b) Teams should be inserted just before dawn.

(c) Teams should be inserted on or within 1 to 2 kilometers of the hide or surveillance site. Being inserted farther away will cause the teams to consume too much water. With the observation in this terrain, teams cannot carry the water required.

(d) Teams should carry extra water and cache it on the LZ.

(3) *Movement.*

(a) Teams movement rates average 1 kilometer per hour during the day and 3 kilometers per hour during night.

(b) Because terrain features are few and maps are not accurate, soldiers should use a global positioning system.

(c) Teams should walk on rocks and shale to aid in counter tracking.

(d) Teams can move faster on wet or dark sand; loose or dune sand demands slower movement.

(4) *Hide or surveillance site.*

(a) Teams should use diamond desert camouflage nets to construct hide or surveillance sites.

(b) Teams should establish hide and surveillance sites together because of unlimited observation.

(c) Teams must conduct surveillance from a point higher than the named area of interest; afternoon heat (1100 to 1600) obscures optics at ground level and vehicles are difficult to identify beyond 4 kilometers.

(d) To identify vehicles at night teams must move closer (within 2 kilometers) to the objective.

(e) Teams can make hasty subsurface hides in sandy soil. Below 6 inches, the ground turns into solid rock. Subsurface hides require shoring because the sides will cave in; subsurface hides are for stay-behind operations only.

### **C-3. MOUNTAIN OPERATIONS**

Irregular mountain topography normally provides good concealment and cover. Observation varies from good to poor depending on trees and scrub growth. Surveillance sites near ridges and peaks may provide broad areas of observation. Aircraft movement of teams is often limited by altitude capability, erratic wind conditions, and lack of landing sites. Communication is generally difficult; relay stations may be needed for communication between the teams and base stations. (See FM 90-6 for more information.)

### **C-4. COLD WEATHER OPERATIONS**

In extreme cold, teams are hampered by the need to maintain body warmth. In deep snows, teams must operate on skis or snowshoes; consideration may also be given to the use of dogsleds and skimobiles. Long-range weather forecasts are important, particularly during the pre-infiltration phase. Deep snow provides concealment for stationary surveillance sites, but increases the difficulty of orientation and concealment of moving teams. Radio communication is seriously affected by magnetic storms, aurora] effects, and ionospheric disturbances. The radio operator must be sure to select the correct frequencies. Trafficability and load-bearing qualities of ice and snow crust are so significant that determining these factors may be a part of the surveillance mission assigned the team. Survival is difficult during extreme winter conditions. The team must establish a warming area to operate for extended periods at maximum efficiency. Northern summer conditions are characterized by long periods of daylight and numerous water obstacles and marshy areas. The teams use boats designed to navigate northern waterways, when aircraft or ground operations are restricted.

## APPENDIX D

**COMMUNICATIONS**

*LRSU mission success depends on the LRS team's ability to report intelligence gathered. An LRS team that can see everything and report nothing is useless. LRSUs normally use high-frequency radios to report information and receive instructions. Because of the complex nature of using the HF radio spectrum, a LRSU radio operator must have an in depth knowledge of radios, antennas, and radio wave propagation.*

**D-1. HIGH-FREQUENCY RADIO FUNDAMENTALS**

For successful communication, HF radio performance depends on the type of emission (voice or burst device), transmitter power output, and type of antenna. The challenge facing HF radio operators is tremendous. They must use their HF radio systems to transmit important information to the DOB or AOB. The HF radio operator must continually adjust his system to compensate for changing conditions and missions. Knowledgeable operators, properly constructed antennas, and propagated frequencies are the key to successful, effective HF radio communication.

a. Of the variables that affect HF radio communication, the antenna **is** the one that an operator has the most control over. Proper antenna use greatly increases the chances of effective communication. Achieving the NVIS (near vertical incidence sky-wave) effect can be done with any antenna used with HF radios to help eliminate skip zones. This concept enables team RATELOs to establish communication with the COB or DOB. Consequently, NVIS enables the LRSU operations center to forward the information to the corps or division G2. (Figure D-1, page D-2.)

b. Extensive training of team members on HF radio systems and antenna construction is essential to mission success. (See FMs 11-64, 11-65, 24-1, and 24-18 for more information.)

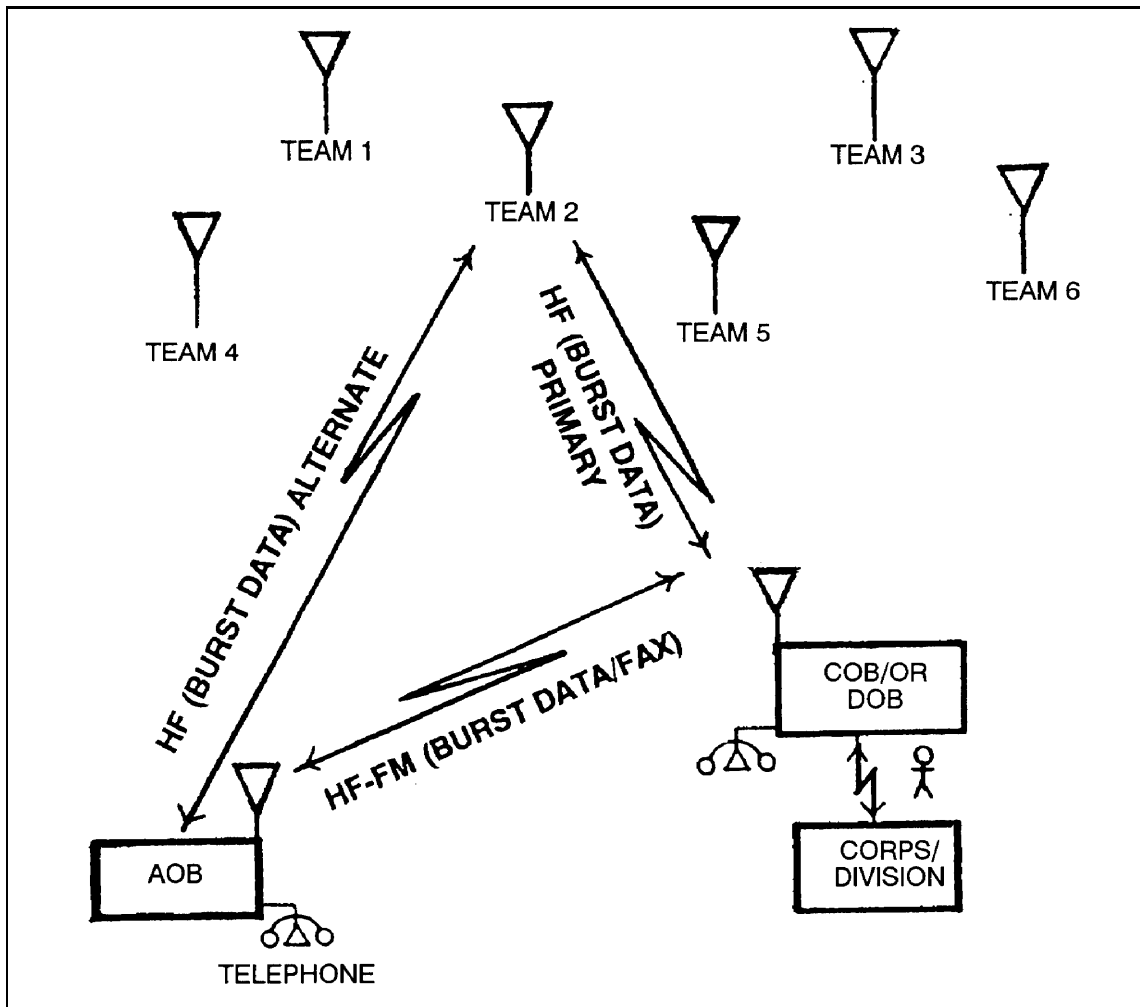
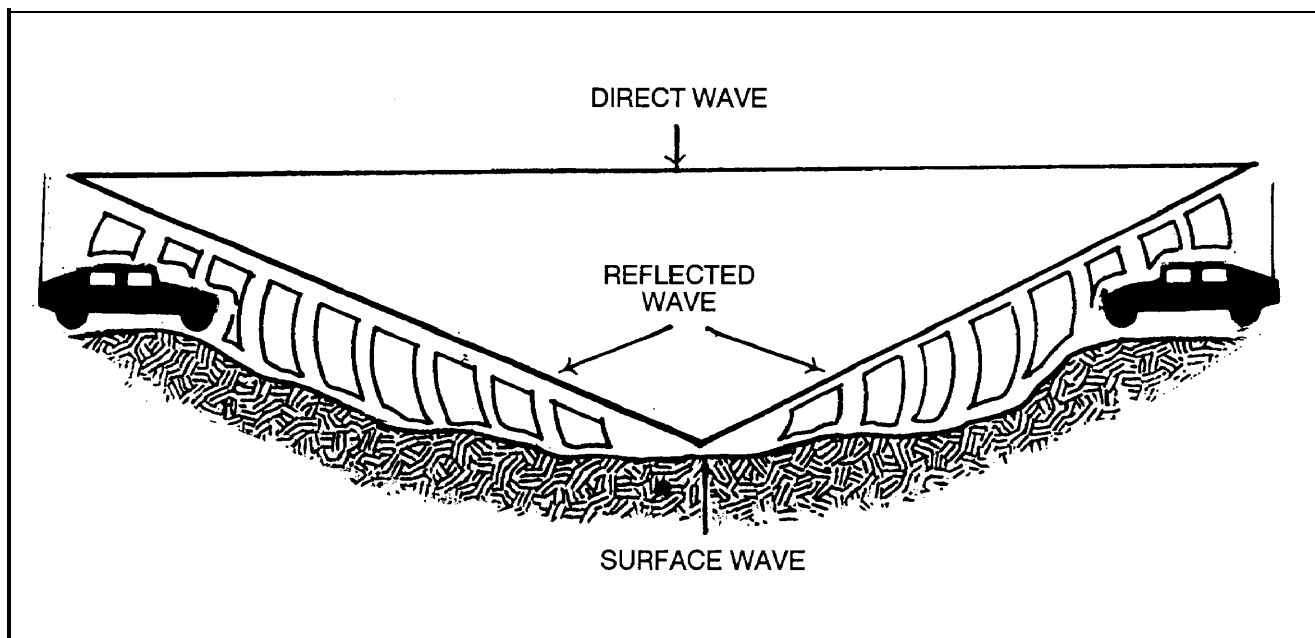

Figure D-1. Overall communications capabilities.

## D-2. FREQUENCY PROPAGATION

High-frequency communication (2 to 30 MHz) is done by either ground-wave or sky-wave propagation. With low-powered, man-pack radios, ground-wave communication can be established out to 30 kilometers. High-powered vehicle-mounted equipment can extend that range to about 100 kilometers. The coverage from sky-wave communication can vary from several kilometers to thousands of kilometers.

a. **Ground-Wave Propagation.** Ground-wave propagation involves the transmission of a radio signal along or near the surface of the earth. The ground-wave signal is divided into three parts: the **direct wave**, the **reflected wave**, and the **surface wave** (Figure D-2).



**Figure D-2. Components of ground wave.**

(1) The *direct wave* travels from one antenna to the other in what is called the line-of-sight mode. Maximum line-of-sight distance depends on the height of an antenna above the ground; the higher the antenna, the further the maximum line-of-sight distance. Because the radio signal travels in the air, any obstruction (such as a mountain) between the antennas can block or reduce the signal. For an antenna 10 feet above the ground, 8 kilometers (5 miles) is the maximum line-of-sight distance.

(2) The *reflected wave* reflects off the earth in going from the transmitting antenna to the receiving antenna. Together, the reflected wave and the direct wave are called the space wave.

(3) The *surface wave* travels along the surface of the earth. It is the usual means of ground-wave communication. The surface wave depends on the type of surface between the two antennas. With a good conducting surface, such as seawater, long ground-wave distances are possible. If there is a poor surface between the antennas, such as sand or frozen ground, the expected distance for the surface wave is short. The surface-wave range can also be reduced by heavy vegetation or mountainous terrain.

b. **Sky-Wave Propagation.** Beyond the range covered by the ground-wave signal, HF communications are possible through sky-wave propagation. Sky-wave propagation is possible because of the bending (refraction) of the radio signal by a region of the atmosphere called the ionosphere.

(1) The ionosphere (Figure D-3) is an electrically charged (ionized) region of the atmosphere that extends from about 60 kilometers (37 miles) to 1,000 kilometers (620 miles) above the earth's surface. The ionization results from energy from the sun and causes radio signals to return to earth. Although the ionosphere exists up to 1,000 kilometers, the important area for HF communication is below 500 kilometers. This area is divided into four regions: D, E, F1, and F2.

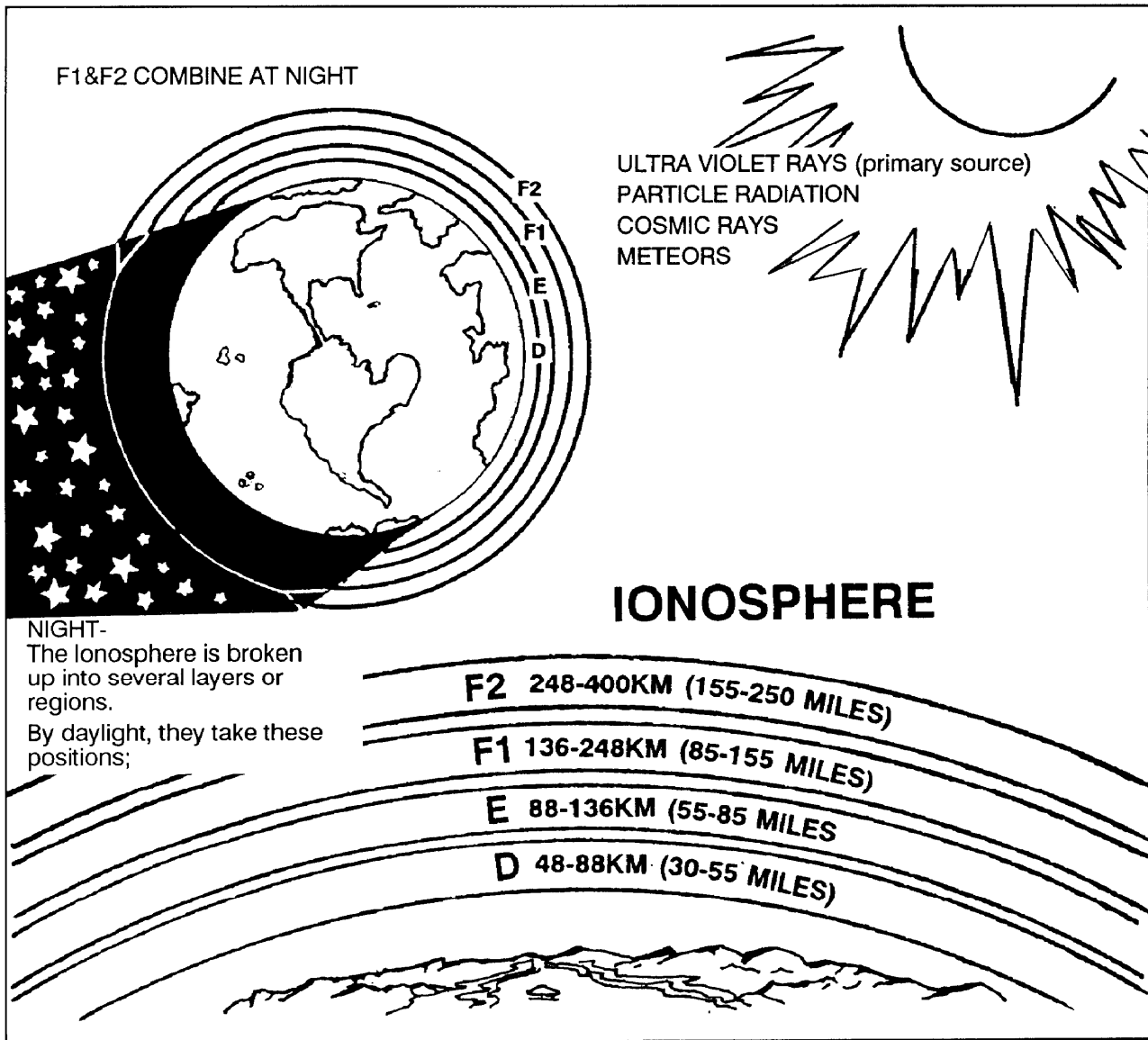

Figure D-3. Structure of the ionosphere.



(a) The majority of HF sky-wave communications depend on the F1 and F2 regions, with the F2 region being used the most for long-range daytime communications.

(b) The E region is the next lower region. It is present 24 hours a day, although at night it is much weaker. The E region is the first region with enough charge to bend radio signals. At times, parts of the E region become highly charged and can either help or block out HF communication. These highly charged areas are called sporadic E. They occur most often during the summer.

(c) The D region is closest to earth and only exists during the day. It cannot bend a radio signal back to earth, but it does play an important role in HF communication. The D region absorbs energy from the radio signal passing through it, thereby reducing the strength of the signals.

(2) The bending of the radio signal by the ionosphere depends on the frequency of the radio signal, the degree of ionization in the ionosphere, and the angle at which the radio signal strikes the ionosphere. At a vertical (straight up) angle, the highest frequency bent back to earth is called the critical frequency. Each region of the ionosphere (E, F1, and F2) has a separate critical frequency. For a vertical angle, signals above the highest critical frequency pass through all ionospheric regions and on into outer space. Frequencies below the critical frequency of a region are bent back to the earth by that region; however, if the frequency is too low, the signal is absorbed by the D region. To have HF sky-wave communication, a radio signal must be a high enough frequency to pass through the D region, but not so high a frequency that it passes through the reflecting region. Thus, radio operators must have current propagation charts from which to choose the most effective frequency during a given time period. To achieve an NVIS effect, the radio operator subtracts 20 percent from frequencies propagated on commercial computer propagation programs.

(3) The angle at which a radio signal strikes the ionosphere plays an important part in sky-wave communication. As mentioned, any frequency above the critical frequency passes through the reflecting region. If the radio signal having a frequency above the critical frequency is sent at an angle, the signal is bent back to earth instead of passing through the region. This can be compared to skipping stones across a pond. If a stone is thrown straight down at the water, it penetrates the surface. If a stone is thrown at an angle to the pond, the stone skips across the pond. For every circuit, there is an optimum angle above the horizon called the takeoff angle. It produces the strongest signal at the receiving station. This optimum takeoff angle is used to select the antenna for a specific circuit. By placing an antenna between

1/8 wavelength and 1/4 wavelength above ground level, the radio operator achieves an NVIS effect and reduces or eliminates any skip zone.

(4) Depending on the frequency, antenna, and other factors, an area may exist between the longest ground-wave range and the shortest sky-wave range where no signal exists. This is called the skip zone and no communication is possible (Figure D-4). The NVIS effect can eliminate this problem.

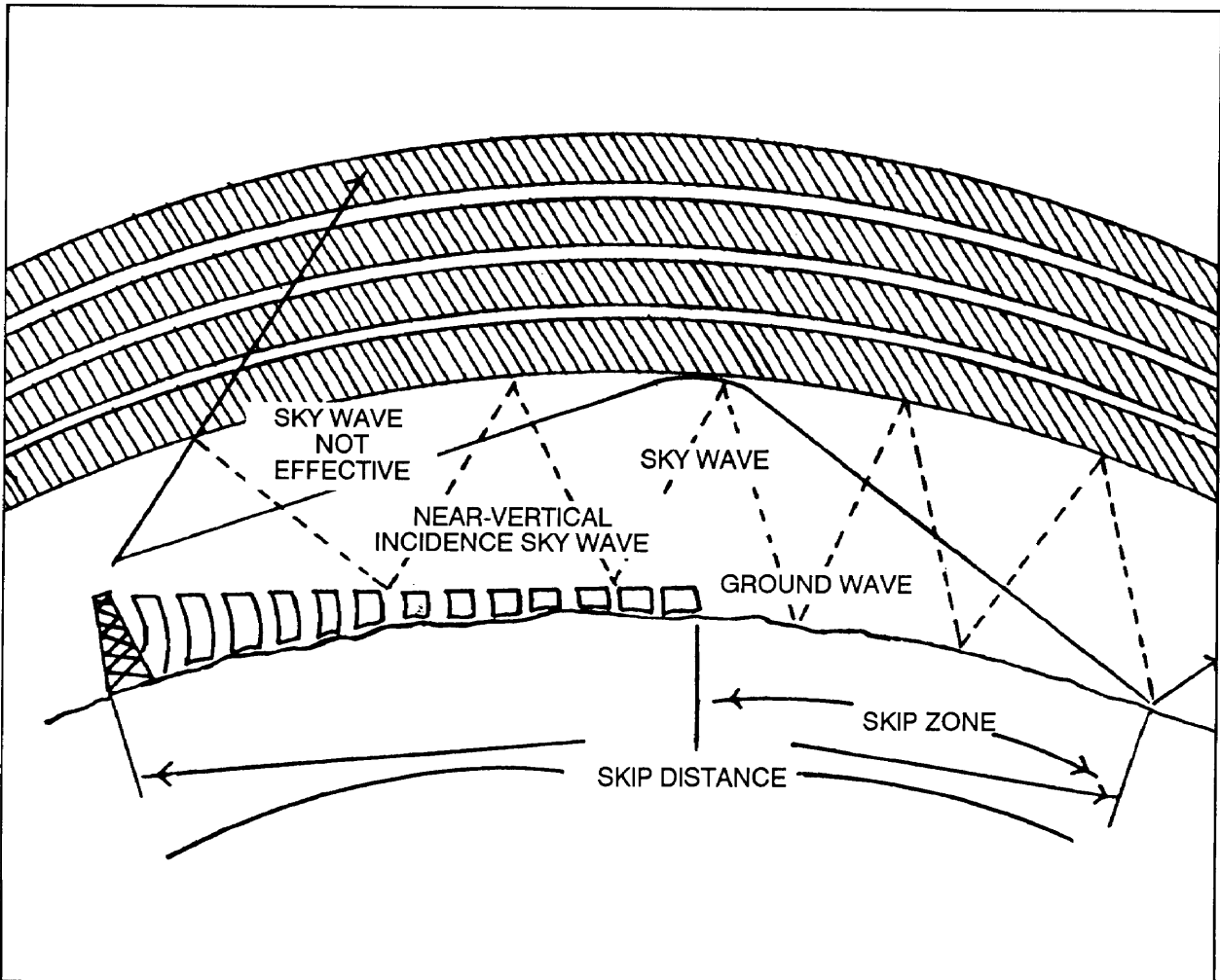

**Figure D-4. HF skip zone and use of NVIS.**

(5) HF propagation involves much more than what has been presented. For example, multiple frequencies are usually needed to maintain sky-wave communication. As a minimum, two frequencies, one for day and one for night are normally required.

### D-3. ANTENNA THEORY AND CONSTRUCTION

To select antennas for HF radio communication, the operator needs to know the concepts. This paragraph defines several basic terms and relationships, helping the operator select the best antenna.

a. **Wavelength and Frequency.** In radio communication, there is a definite relationship between antenna length and frequency wavelength. This relationship is important when building antennas for a specific frequency or frequency range. The wavelength of a frequency is the distance an electromagnetic wave travels to complete one cycle. (See Figure D-5.)

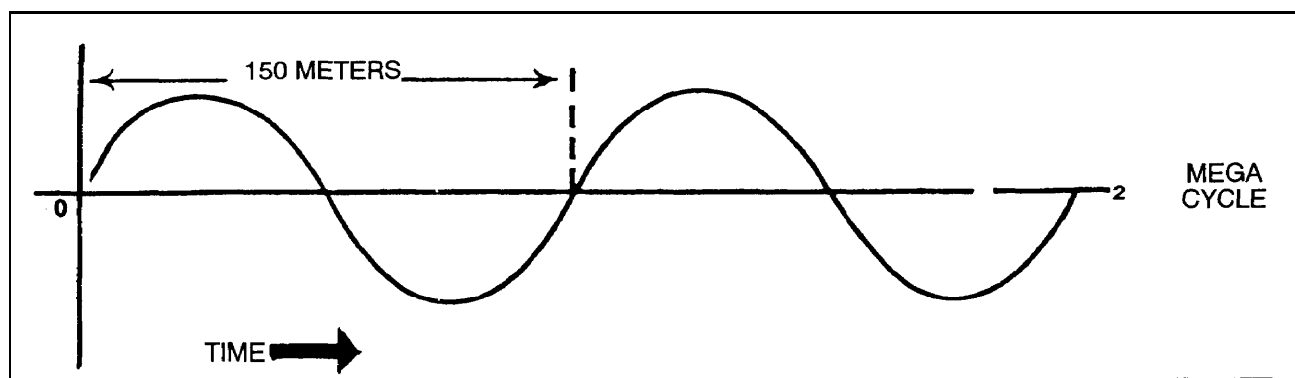

**Figure D-5. Measurement of a wavelength.**

b. **Resonance.** Antennas are classified as either resonant or nonresonant, depending on their design. Both resonant and nonresonant antennas are commonly used on tactical circuits.

(1) A resonant antenna matches the length of a frequency's wavelength. In a resonant antenna, almost all of the radio signals sent to the antenna are radiated. If a resonant antenna is used for radio communication, a separate antenna must be built for each frequency used with the radio.

(2) If the antenna is used for a frequency other than the one it matches, it is nonresonant and much of the signal is lost. A nonresonant, or broadband, antenna effectively radiates a broad range of frequencies with lower efficiency. When a nonresonant antenna is used, large losses of signal power occur. Signal energy from the antenna is reflected and causes standing waves on the antenna. A measure of these standing waves, called standing wave ratio, is used to determine if an antenna is resonant at a particular frequency. A 1-to-1 standing wave ratio is the ideal situation, but 1.1-to-1 is about the best that can be done. When building wire antennas, the length of the antenna should be adjusted until the lowest standing wave ratio is measured. A 3-to-1 standing wave ratio is acceptable (check the operator's manual for the particular radio in use to determine the maximum standing wave ratio

that the radio can tolerate.) In some radios, the power output of the transmitter is automatically lowered if the standing wave ratio is too high.

c. **Polarization.** Polarization is the relationship of radio energy radiated by an antenna to the earth. The most common polarizations are horizontal (parallel to the earth's surface) and vertical (perpendicular to the earth's surface); however, others, such as circular and elliptical, also exist. A vertical antenna normally radiates a vertically polarized signal, and a horizontal antenna normally radiates a horizontal signal. In HF ground-wave, both the transmit and receive antennas should have the same polarization for best communication. In the case of HF ground-wave propagation, vertical polarization should be used. For HF sky-wave propagation, the polarization of the transmitter and receiving antennas does not have to be the same because of the random changing of the signal as it is bent by the ionosphere. This random changing allows the use of vertical or horizontal polarization at the transmitter or receiving antenna. For sky-wave propagation, horizontal polarization is recommended to be most effective.

d. **Classification.** Antennas are classified according to how radio energy is radiated: omnidirectional, bidirectional, or directional.

(1) *Omnidirectional.* An omnidirectional antenna radiates radio energy in a circular pattern so all directions on the ground receive an equal amount of radiation (Figure D-6). The most common omnidirectional antenna is the whip. Other examples are the quarter-wave vertical (RC-292, OE-254) and the crossed dipole (AS-2259). The omnidirectional antenna radiates and receives energy equally well in all compass directions. This antenna is used when it is necessary to communicate in separate directions at once. However, it is also more susceptible to interference from all directions.

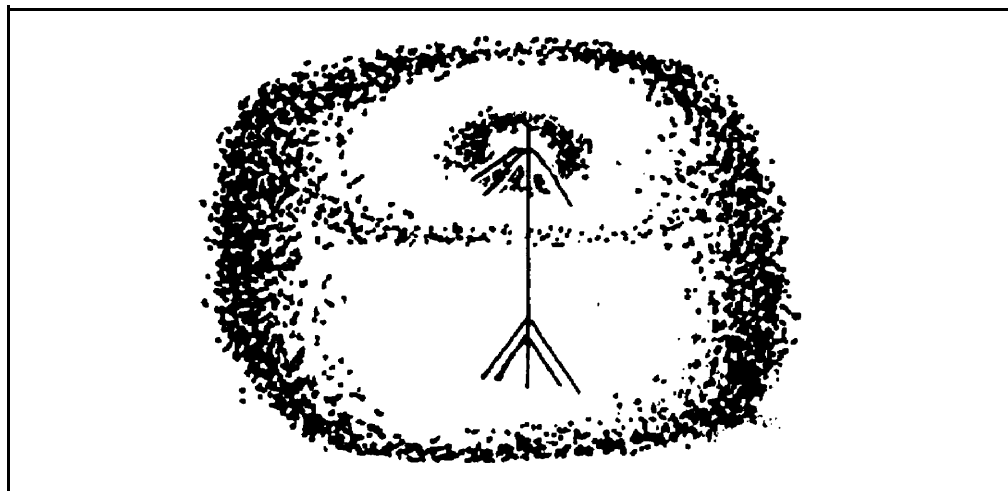
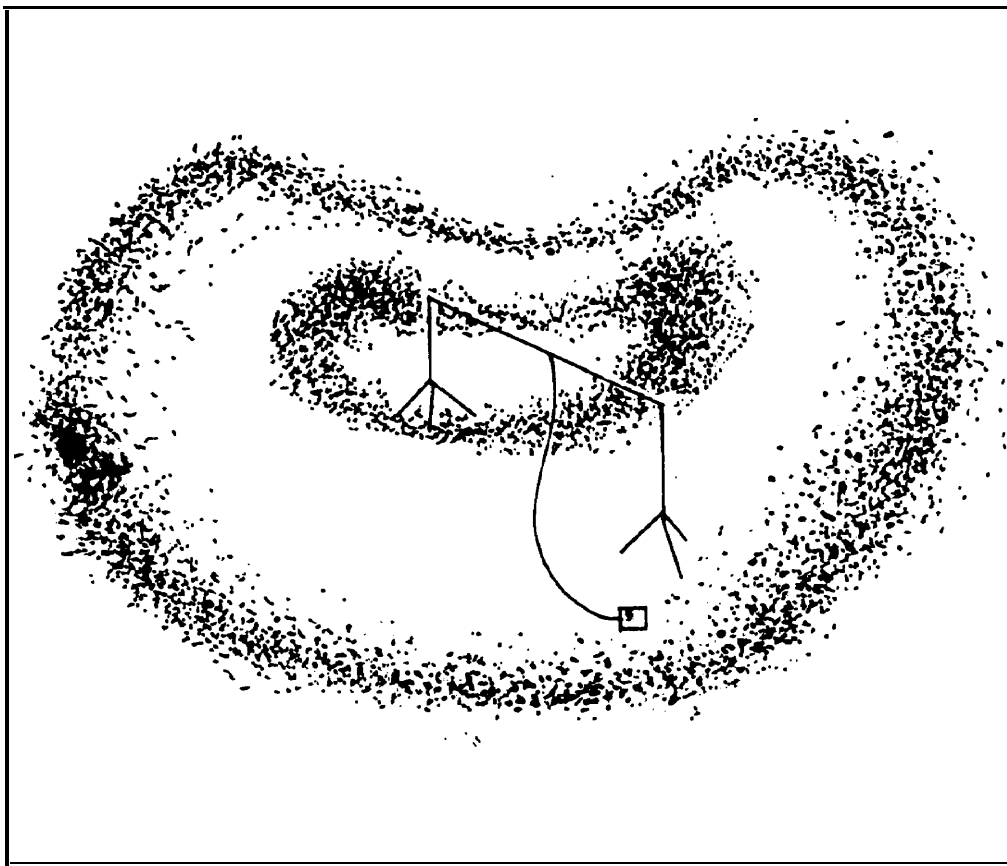

Figure D-6. Omnidirectional antenna pattern.

(2) *Bidirectional*. A bidirectional antenna has two main lobes of radio energy opposite each other with a null between the lobes (Figure D-7). These antennas produce a stronger signal in the two opposing directions while reducing the signal in other directions. The tactical bidirectional antennas most commonly used are sloping wires, random length wires, and half-wave dipoles. Bidirectional antennas are usually used on point-to-point circuits and in situations where the antenna null can be positioned to reduce or block out interfering signals when receiving. Although bidirectional antennas are more difficult to find direction (ground-wave), they can be used when several antennas are closely located. Placement of other antennas in the null of bidirectional antennas reduces interference and interaction between the antennas. A drawback of bidirectional antennas is that they have to be correctly oriented to radiate in the desired directions. However, lowering the antenna to create the NVIS effect increases the radiation pattern allowing less accuracy in orientation of the antenna.



**Figure D-7. Bidirectional antenna pattern.**

(3) *Directional*. A directional antenna has a single large lobe of radio energy in one direction (Figure D-8). It is much like a bidirectional antenna with one of its lobes cut off. Several bidirectional antennas (long-wire, sloping-Vee) are made directional by adding a terminating resistor that absorbs the second main lobe. A terminating resistor matches the antenna. A terminating resistor must be able to absorb one-half the power output of the connected transmitter and provide 400 to 600 ohms of resistance. A directional antenna concentrates almost all the radio signal in one specific direction; therefore, it must be carefully oriented. Depending on the antenna design, the main lobe of a directional antenna can cover 60 degrees or more or be a narrow pencil beam. Directional antennas are used on long-range point-to-point circuits where the concentrated radio energy is needed for circuit reliability. Directional antennas are difficult for the enemy to find the direction of transmission.

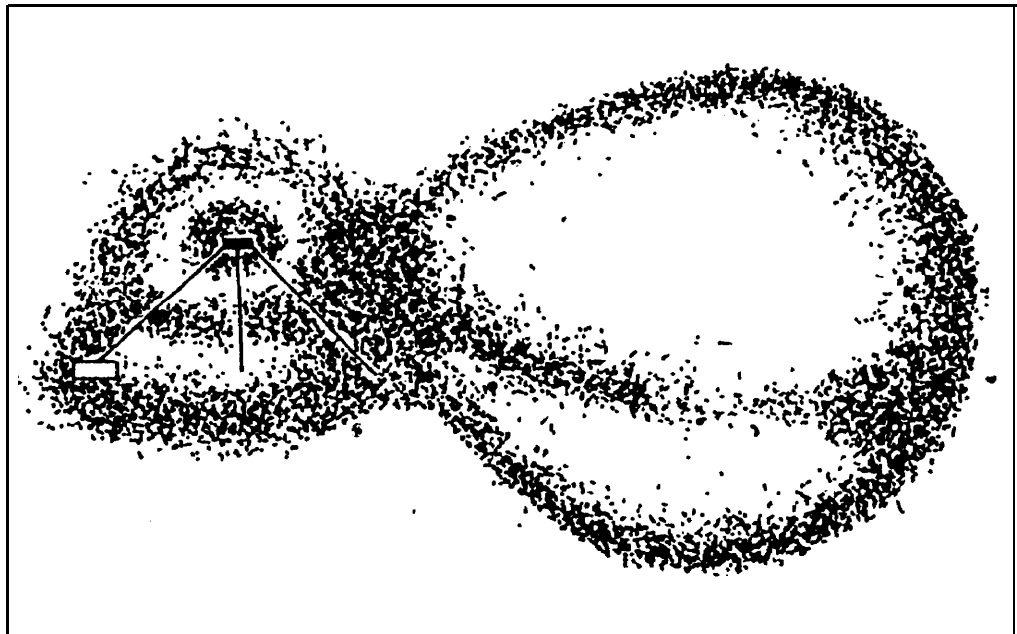

**Figure D-8. Directional antenna pattern.**

**e. Antenna Construction and Selection.** Antenna construction is limited only by imagination. There are many types and configurations. However, the operator must be careful not to construct an antenna that has a high standing wave ratio, which can damage radio equipment. Standing wave ratio meters should be used when testing or using unfamiliar antennas. In selecting an antenna for an HF circuit, the operator must know the type of propagation.

(1) Ground-wave propagation requires low takeoff angles and vertically polarized antennas. The whip antenna provides good omnidirectional ground-wave radiation. If a directional antenna is needed, the operator selects one with a good low-angle vertical radiation.

(2) Sky-wave propagation makes the selection of an antenna more complex. The first step is to find the distance between radio stations so that the required takeoff angle can be determined. The takeoff angle versus the distance tables gives approximate takeoff angles for day and night sky-wave propagation. If the circuit distance is 966 kilometers (600 miles) during the day, the required takeoff angle is about 25 degrees. At night, it is 40 degrees. Therefore, the operator selects an antenna that has high gain from 25 to 40 degrees. This step can be omitted if the propagation predictions give the required takeoff angles. By subtracting 20 percent from these predictions for use with NVIS constructed antennas, the operator uses a planning range of 0 to 300 miles for short-range HF communication.

(3) The radio operator decides what type of coverage is required. If the radio circuit consists of mobile (vehicular) stations or many stations at different directions from the transmitter, an omnidirectional antenna is required. If the circuit is point to point, a bidirectional or a directional antenna can be used. Normally, the receiving station locations dictate this choice.

(4) Before an antenna can be selected, the operator examines the materials available for antenna construction. If a horizontal dipole is to be erected, at least two supports are needed. (A third support in the middle is required for frequencies of 5 MHz or less.) If these supports are not available and there are no other items that can be used as supports, the dipole cannot be used. The operator checks the site of the antenna to determine if the proposed antenna will fit.

(5) Another consideration is the site itself. More times than not, the tactical situation determines the position of the communication antennas. The ideal setting is a clear flat area with no trees, buildings, fences, power lines, or mountains. Unfortunately, such an ideal location is seldom available for the tactical communicator. In choosing an antenna site, the radio operator selects an area as flat and as clear as possible. In many situations, an antenna must be put up in less ideal sites. This does not mean that the antenna will not work, but that the site affects the pattern and functioning of the antenna.

f. **Half-Wave Dipole Antenna.** The half-wave dipole is a balanced resonant antenna (Figure D-9, page D-12). It produces its maximum gain for a narrow range of frequencies, normally 2 percent above and below the design frequency. Since frequency assignments are normally several megahertz apart,

the operator must build a separate dipole for each assigned frequency. The length of a half-wave dipole is calculated from using the following formula:

$$\text{Length} = \frac{468}{\text{frequency}}$$

The height of a dipole is normally kept at 1/4 wavelength to 1/2 wavelength above ground level for long-range sky-wave. For NVIS (0 to 300 miles), the antenna should be erected between 1/8 wavelength and 1/4 wavelength above ground level. This rule also applies to the inverted Vee and sloping Vee antennas.

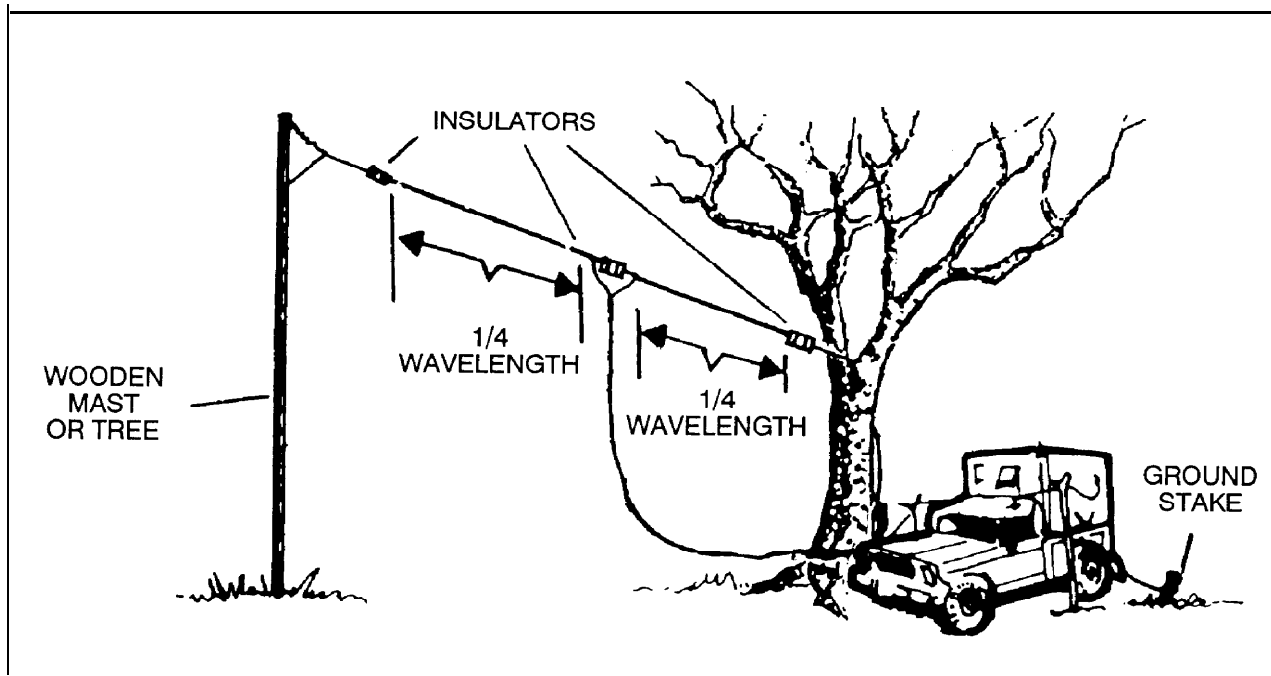

**Figure D-9. Half-wave dipole antenna.**

g. **Inverted Vee.** The inverted Vee, or drooping dipole, is similar to a dipole but uses only a single center support. Like a dipole, it is used for a specific frequency and has a bandwidth of plus or minus 2 percent of design frequency. Because of the inclined sides, the inverted Vee antenna produces a combination of horizontal and vertical radiation; vertical off the ends and horizontal broadside to the antenna. All the construction factors for a dipole also apply for the inverted Vee. The inverted Vee has less gain than a dipole, but the use of only a single support could make this the preferred antenna in some tactical situations. (See Figure D-10).



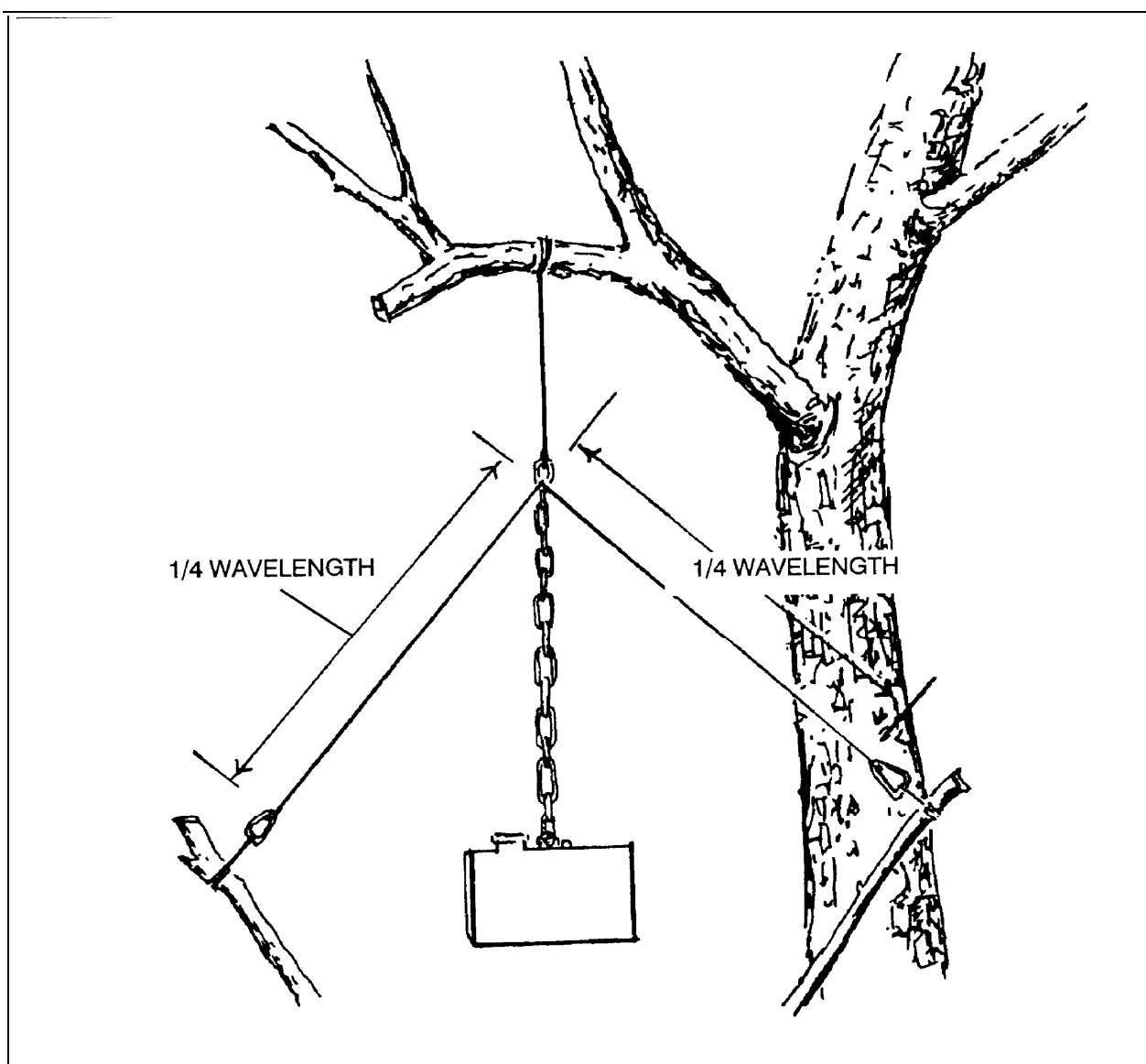

**Figure D-10. Inverted Vee antenna.**

h. **Long-Wire Antenna.** Along-wire antenna is one that is long compared to a wavelength. A minimum length is  $1/2$  wavelength; however, antennas that are at least several wavelengths long are needed to obtain good gain and directional characteristics. The construction of long-wire antennas is simple and straight forward. The dimensions or adjustments are critical. Along-tire antenna accepts power and radiates it well on any frequency for which its overall length is not less than  $1/2$  wavelength (Figure D-11, page D-14).

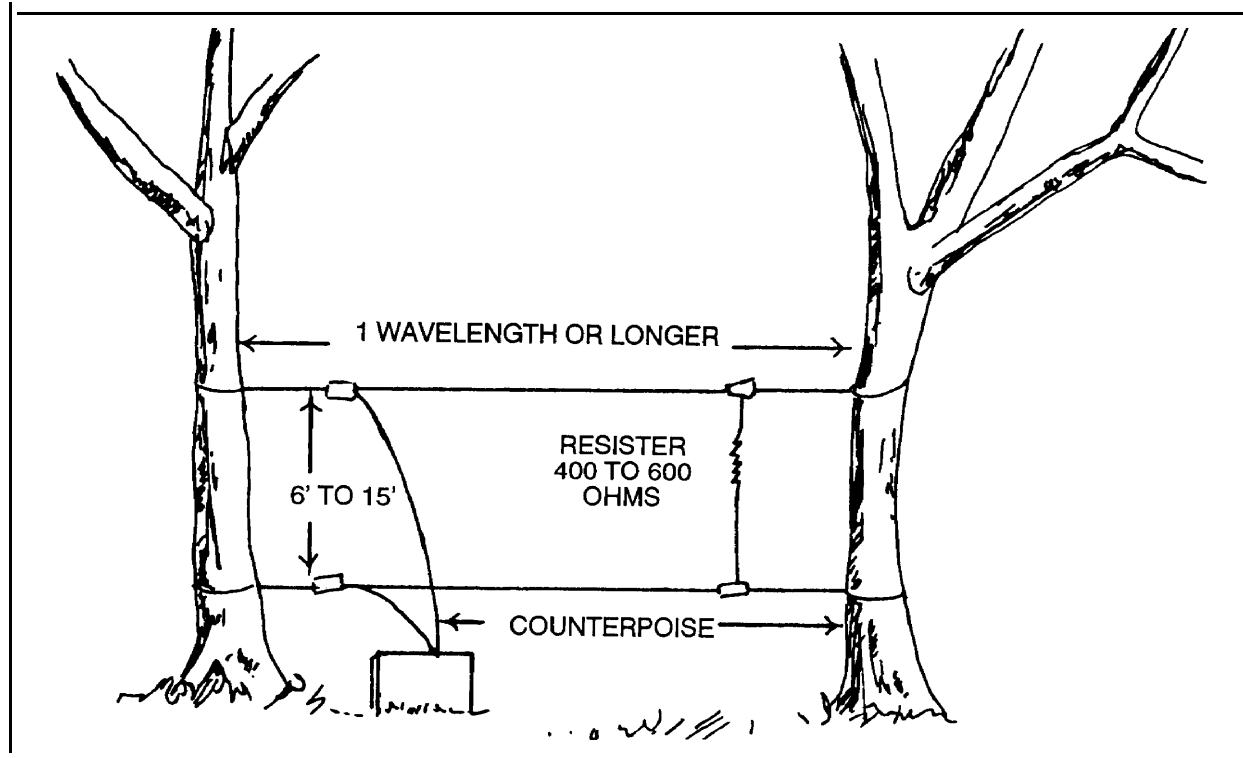

Figure D-11. Long-wire antenna.

(1) Along-wire antenna is made directional by placing a terminating resistor at the distant station end of the antenna. The terminating resistor should be a 600-ohm noninductive resistor capable of absorbing at least one-half of the transmitter power. Terminating resistors are part of some radio sets. They can also be locally made, using supply system parts (National Stock Number 5905-00-764-5573, 100-watt, 106-ohm resistor).

(2) Building a long-wire antenna only requires wire, support poles, insulators, and a terminating resistor (if directionality is desired). The only requirement is that the antenna be strung in as straight a line as the situation permits. The height of the antenna is only 15 to 20 feet above ground so that tall support structures are not required.

i. **Sloping Vee.** The sloping Vee is a short- to long-range sky-wave antenna that is reasonably simple to build in the field (Figure D-12). The gain and directivity of the antenna depend on the leg length. For reasonable performance, the antenna should be at least  $1/2$  wavelength long. To make the antenna directional, terminating resistors are used on each leg on the open part of the Vee. The terminating resistors should be 300 ohms and be capable of absorbing one-half of the transmitter's power output. These

terminating resistors are either procured or are locally made. Using the terminating resistors, the operator aims the antenna so that the line cutting the Vee in-half is pointed at the distant station.

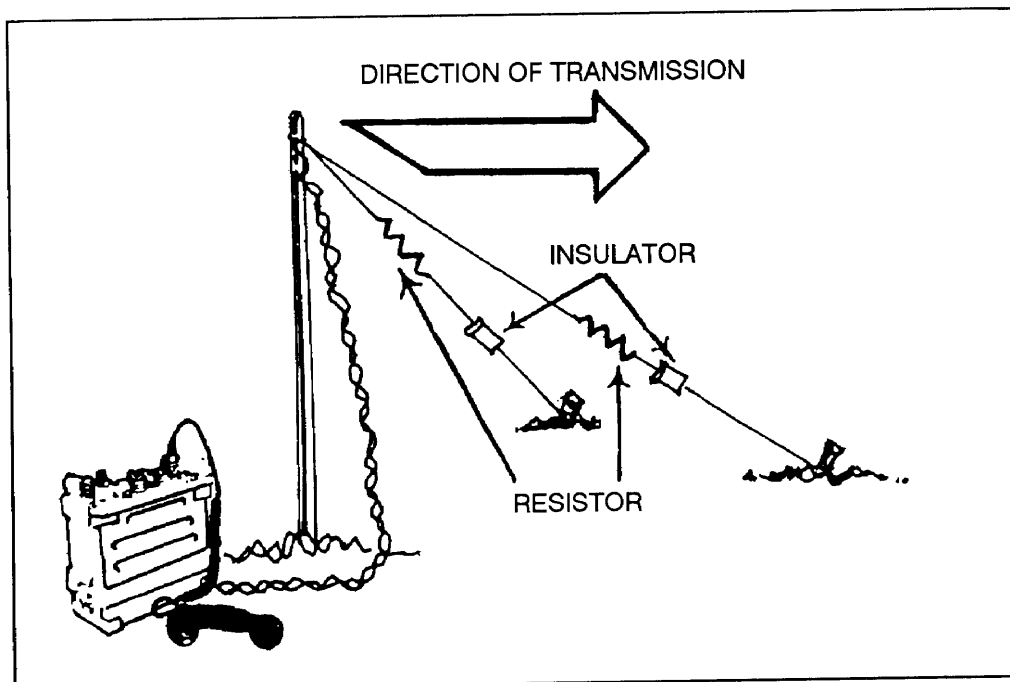

Figure D-12. Terminated sloping Vee antenna.

#### D-4. FIELD-EXPEDIENT TECHNIQUES

Operators must know the importance of field-expedient antennas. Field-expedient antennas are necessary if conventional antennas are damaged or missing parts.

a. **Repair of Damaged Antenna.** A broken whip can be temporarily repaired in several ways.

(1) If the whip is broken in two sections, the operator can join the sections. First, the radio operator removes the paint and cleans the sections where they join to ensure a good electrical connection. He places the sections together and secures them with bare wire or tape. (See Figure D-13, page D-16.)

(2) If the whip is badly damaged, a length of field wire (WD1/TT) of the same length as the original antenna can be used. The radio operator removes the insulation from the lower end of the field wire antenna, twists the conductors together, sticks them in the antenna base connector, and secures it with a wooden block. The antenna wire is supported by a tree or a pole (Figure D-14, page D-16).

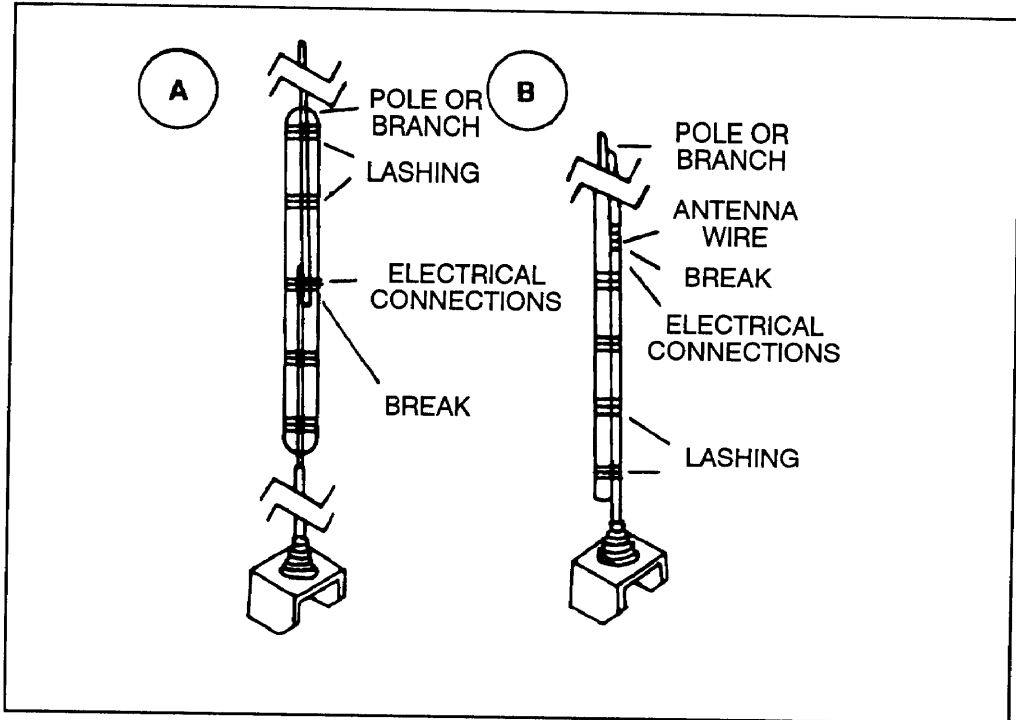

Figure D-13. Using broken sections for emergency repair.

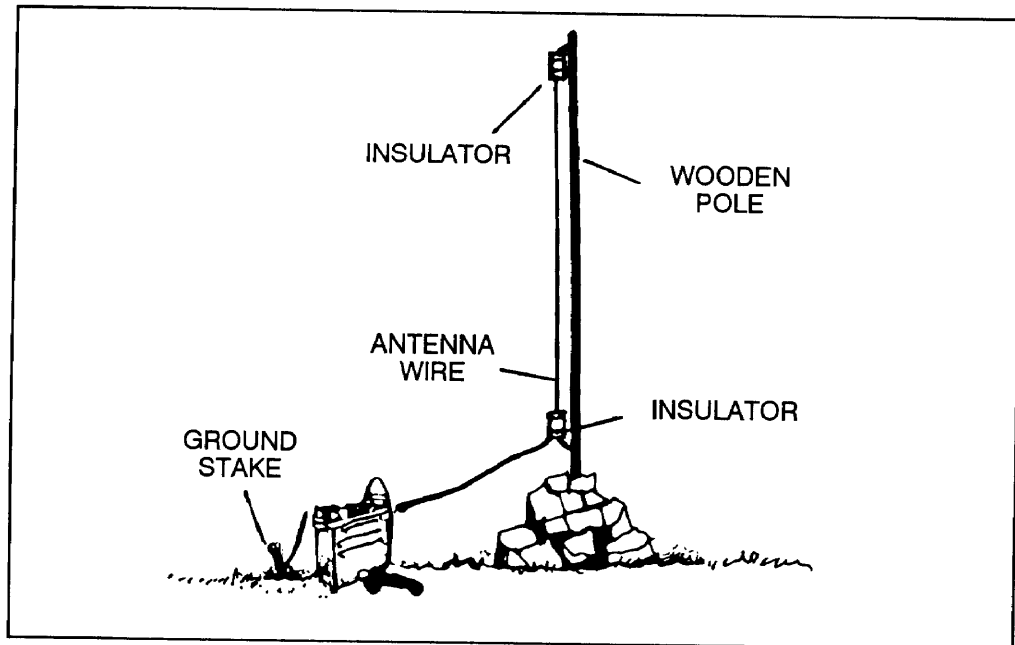
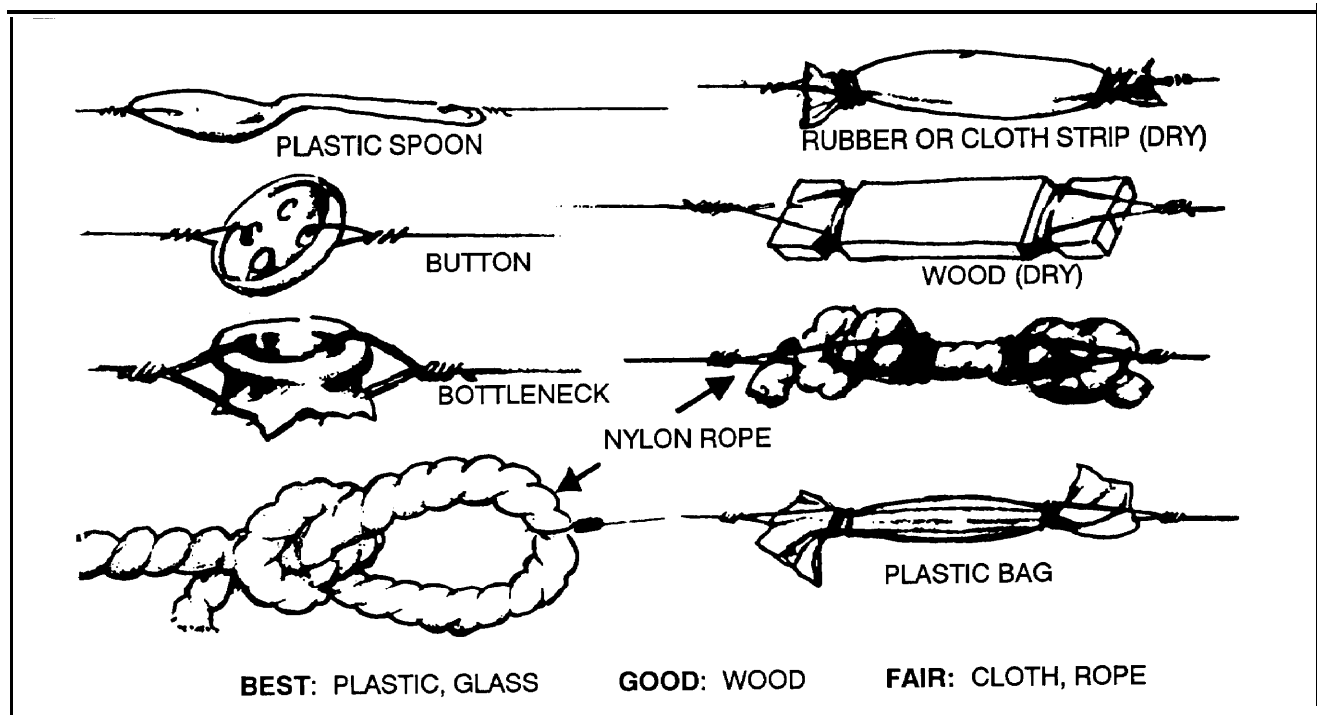

Figure D-14. Using field wire as an emergency whip.

b. **Insulators.** Insulators can be made from items that are readily available. The operator should be careful when selecting any material that holds water (cloth, rope). In a rainstorm, these items absorb water and lose their insulating characteristics. (See Figure D-15.)



**Figure D-15. Expedient insulators.**

c. **Supports.** Many expedient antennas require supports to hold the antenna above the ground. The most common supports are strong trees that can survive heavy windstorms. However, even the largest trees sway enough in the wind to break wire antennas. To keep the antenna taut and to prevent it from breaking or stretching as the trees sway, the operator attaches a spring or piece of old inner tube to one end of the antenna. If a small pulley is available, he attaches the pulley to the tree and passes a rope through the pulley. Then, he attaches the rope to the end of the antenna, and attaches a heavy weight to the other end of the rope. This allows the tree to sway without straining the antenna.

d. **Terminating Resistors.** Terminating resistors have been a continual problem for the field communicator. Resistors for low-power (man-pack) HF radios are readily available from commercial radio supply stores. Carbon resistors that can dissipate more than 5 watts are hard to find. However, the

5-watt resistors can be connected in parallel to make a terminator to handle greater power. For example, eight 5-watt, 4,000-ohm resistors connected in parallel results in a 500-ohm, 40-watt terminator. The 5-watt resistor still does not solve the problem of high power HF terminators. A terminator for a 1,000-watt transmitter requires 100 5-watt resistors. A 100-watt, 106-ohm resistor (National Stock Number 5905-00-764-5573) can be mounted in series on a single insulating board to form a terminator for high-powered transmitters.

e. **Expedient Wire.** If regular antenna wire is not available, the radio operator can use field telephone wire (WDI/TT.) to build antennas. Field wire consists of two insulated wires. Each insulated wire is made up of four copper strands and three steel strands of wire.

(1) When making electrical connections with field wire, the operator uses the copper strands. To identify the four copper strands, he removes about 1 inch of insulation from one end of the insulated wire. He holds the wire where the insulation ends and the strands are bent to the side. When he releases bending pressure, the steel strands snap back to their original position while the copper strands remain bent. These copper strands can then be wrapped around the steel strands to present a copper surface for a good electrical connection.

(2) If field wire is used as the radiating element of an antenna, the two insulated wires in the twisted pair must be connected together at the ends so that electrically the two wires act as one. First, the radio operator tightly twists together all six steel strands from the two wires (for strength). He twists the eight copper strands together (for electrical connection). Then, he twists the copper strands around the steel strands.

(3) When used as a feed line for a dipole antenna, the radio operator connects each of the two insulated wires of the twisted pair to a separate leg of the dipole. At the radio, he connects one wire (any wire) to the center connector of the radio antenna terminal and the second wire to a screw on the antenna case.

(4) In an emergency, any wire of sufficient length can be used for an antenna; for example, barbed wire, electrical wire, fence wire, and metal-cored clothesline. Communication has been successful using metal house gutters and even metal bed springs. A radio operator's mission is not completed until communication is established.

f. **Grounding.** A good electrical ground is needed for two reasons: first, to protect the operator and his equipment; and second, as a radio frequency ground needed by some antennas to function properly. Most radio sets come with a ground rod that should provide enough ground if used properly in good soil. The radio operator ensures the ground rod is free from oil or

corrosion. He ensures the rod is driven into the ground so that the top of the rod is below surface. To ensure a good electrical connection, the top of the ground rod and the end of the ground strap should be clean and bright. A clamp or nut and bolt should be used to make a good mechanical and electrical connection at the ground rod. The end of the ground strap and the radio ground connection should both be cleaned before connection is made.

### **WARNING**

**NEVER USE ANY PIPING OR UNDERGROUND TANKS THAT CONTAIN FLAMMABLE MATERIALS (SUCH AS NATURAL GAS OR GASOLINE).**

(1) If a ground rod is not available, water pipes, concrete reinforcing rods, metal fence posts (protective paint coating removed), or any length of metal can be used. If a water system uses metal pipe, a good ground can be established by clamping the ground strap to a water pipe. Underground pipes, tanks, and metal building foundations also work.

(2) In dry soil, electrical grounds can be improved by adding water and chemicals to the soil. Two common chemicals are epsom salt and common table salt. Epsom salt is preferred because it is not as corrosive as table salt. The radio operator makes a solution of one pound of chemical to one gallon of water. He slowly pours the solution in a hole dug around the ground rod. Water should be added periodically to keep the area damp. If water is not available, urine can be used.

(3) Multiple ground rods can also be used to improve electrical grounds. If enough rods are available, a "star ground" can be built. A single rod is driven in the center of about a 20-foot circle. Ground rods are driven along the outside of the circle. The ground strap from the radio is connected to the center rod, which in turn is connected to the rods along the outside of the circle. The rods on the outside of the circle should also be connected together.

(4) All radio equipment should be grounded to prevent shock and damage to equipment during electrical storms.

## **D-5. LONG-RANGE SURVEILLANCE COMMUNICATIONS EQUIPMENT**

The LRS community uses many different types of communications equipment. This paragraph describes the type and quantity of authorized equipment for LRS companies and detachments. The goal is to standardize equipment in all LRS units.

a. **Team HF Radio, AN/PRC-104.** The AN/PRC-104 is a lightweight radio transceiver that operates in any frequency between 2.0000 and 29.9999 Mhz. Power output is 20 watts. It operates in upper sideband (LRS mission) or lower side band. It is easy to install and operate, and it is well suited for LRS missions. Each team is authorized one radio. (See TM 11-5820-919-12 for more information.)

b. **Team VHF (FM) Radio, AN/PRC-126.** The AN/PRC-126 is a hand-held two-way radio used primarily for interteam communication and ground-to-air communication (extraction). Each team is authorized two radios. (See TM 11-5820-1025-10 for more information.)

c. **Digital Message Device Group, OA-8990/P.** The OA-8990/P is used for message bursts between teams, COB or DOB, and AOB. It stores up to 8 messages in receive memory. A free text or 5-character group format may be used. It is National Defense Area-secure, and messages that are transmitted using this device are encrypted by the operator. Each team is authorized one digital message device group (four per AN/TSC-128) or one KL43CS per team (four per AN/TSC-128). (See TM 11-5820-887-10 for more information.)

d. **Base Radio, AN/GRC-213.** The AN/GRC-213 is a vehicular-mounted, low-power (20 watts) HF radio used for communication between deployed teams and the COB or DOB and AOB. It has the same transceiver as the PRC- 104. Each AN/TSC-128 is authorized three radios. (See TM 11-5820-923-12 for more information. )

e. **Base Radio, AN/GRC-193.** The AN/GRC-193 is a vehicular-mounted, medium- and high-power HF radio with a power output of either 100 or 400 watts. It is used for communication between teams and the COB or DOB and AOB. Each AN/TSC-128 is authorized one radio. (See TM 11-5820-924-13 for more information.)

f. **Encryption Message Burst Device, KL-43C.** The KL-43C is an off-line encryption terminal to send and receive classified messages over unprotected telephone lines and radio nets. It stores up to two messages in memory. It is small and lightweight, and replaces the OA-8890 digital message device group on a one-for-one basis. Each team is authorized one device (four per AN/TSC-128).

g. **Antenna, AN/GRA-50.** The AN/GRA-50 is a component of the AN/PRC-104, AN/GRC-213, and AN/GRC-193 radios. It is a half-wave dipole that can be used for either long-range (2500 miles) or short-range sky-wave (NVIS, 0-300 miles). (See TM 11-5820-467-15 for more information.)

h. **Antenna, AS-2259/GR.** The AS-2259/GR is a component of the AN/PRC-104, AN/GRC-213, and AN/GRC-193 radios. It consists of two inverted Vee dipoles positioned at right angles. It uses a foam-electric center pole as its



coaxial. It uses the NVIS concept to achieve a range of 0 to 300 miles. (See TM 11-5985-379-14&P for more information.)

i. **Communication Shelter, TSC-128.** Six TSC-128s are authorized per corps LRS and four per division LRS. The AN/TSC-128 is the principal component of the long-range surveillance base radio station. One base radio station is made up of two AN/TSC-128s. The LRSC has three base radio stations (six AN/TSC-128s). The LRSD has two base radio stations (four AN/TSC-128s). See Figure D-16, page D-22, for the composition of the AN/TSC-128.

(1) The AN/TSC-128 provides both reception and transmission capability for land-secure-burst data communication over extended ranges, using two identically configured AN/TSC-128 shelters with five or less antennas (three is the preferred number).

(2) The AN/TSC-128 provides continuity during operations to include maintenance periods. Continuity is required during corps and division displacement. Continuity is achieved by using two shelters.

(3) The AN/TSC-128 receives and records at least 2 messages simultaneously, and it can process a minimum of 18 messages in one hour. It allows selective retransmission of messages to the corps or division tactical operations center over the local or wide area communication system.

(4) The AN/TSC-128 provides informal record traffic to be originated and terminated by the LRSU base radio station and communicated to the TOC support element and the MI battalion headquarters.

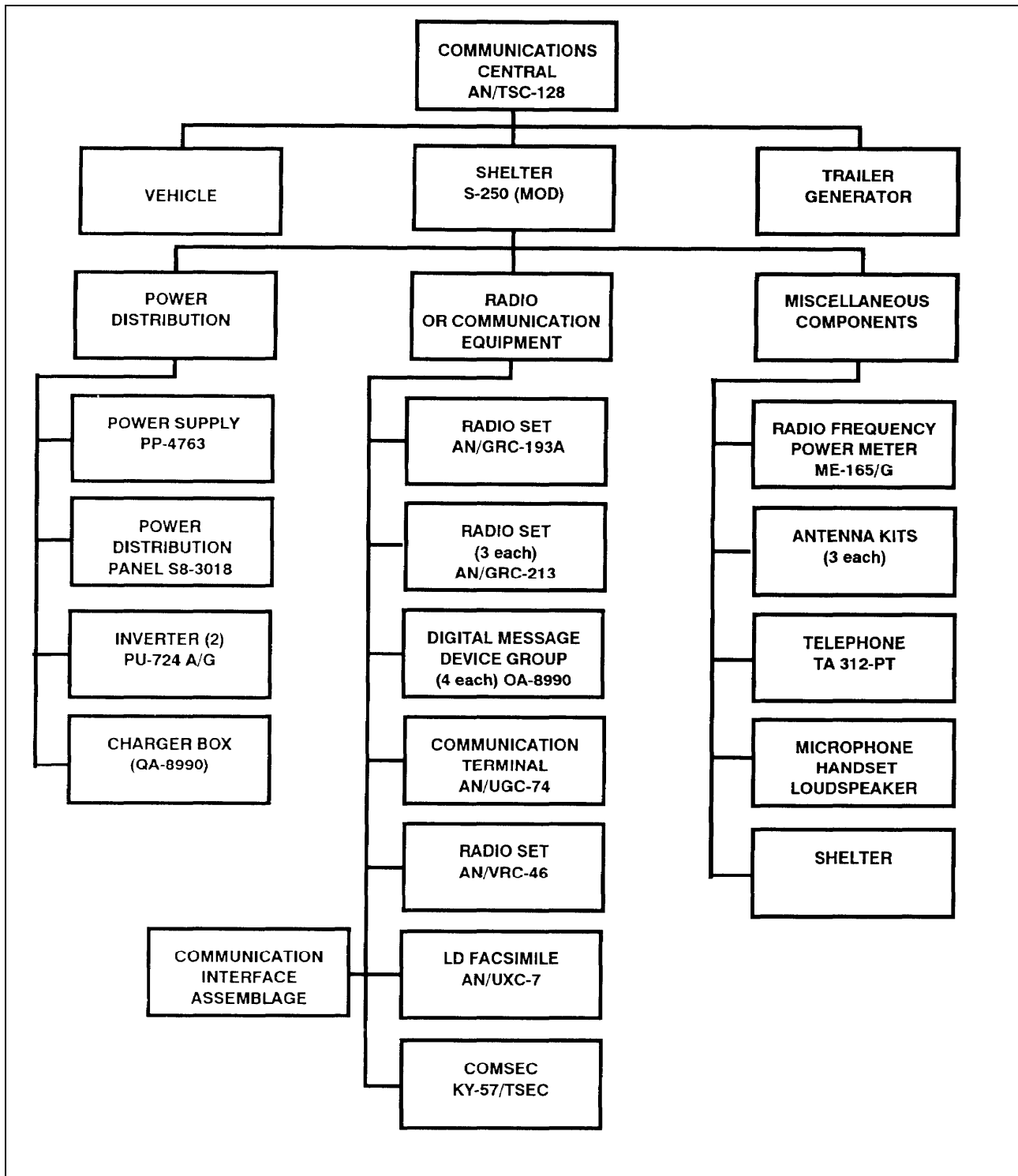

Figure D-16. Composition of AN/TSC-128.

## D-6. SITE SELECTION

The reliability of radio communication depends largely on the selection of a good radio site. The site should satisfy technical, tactical, and security requirements. Several important factors must be considered when setting up a radio site. The site must be accessible from the hide site. It must be defensible since escape from the enemy will not be as fast as with a full LRS team. An important consideration is the use of terrain to aid in communication. Also, the site must have good cover and concealment without interfering with the erection of antennas. Moving the site may be necessary if interference (man-made or not) becomes a problem.

a. An alternate site should also be planned. Also, the radio operator considers the following:

- Always use a resonant antenna if possible to communicate.
- Always try to use a directional antenna.
- Remember that WD-1 is insulated, but not shielded. Using it as a lead-in wire to the antenna causes it to lose signal strength before it reaches the antenna.

b. The COB or DOB is the primary link between the deployed teams and corps or division G2. COB or DOB stations are normally located well within the security umbrella of the corps or division main and should be close enough to the G2 section to facilitate a wire line for reporting purposes. The AOB may collocate if communication is established and maintained between the deployed teams and the COB or DOB. For increased survivability and redundancy, the AOB may be located elsewhere such as the corps or division rear. If communication cannot be established or maintained between the teams and the COB or DOB, the AOB is moved forward or rearward (mission dictated) to establish communication with the deployed teams and the COB or DOB. When the AOB is used as the primary reporting link, it must maintain a constant communication path with the COB or DOB, while the COB or DOB moves with the corps or division main.

## APPENDIX E

**LRSU HIDE AND SURVEILLANCE SITES**

*Surveillance is the primary mission of LRSU. When conducting surveillance, the leader reconnoiters and selects a hide position and a surveillance position. The two positions can be in the same location. This decision is based on an estimate of the situation and the factors of METT-T. The hide site provides a base from which to stage HF or satellite communications (either a remote communication site or directly from the hide site). It also reduces the number of personnel at the surveillance site, thereby reducing the chance of compromise. The hide site provides an operational base for the team from which personnel can be rotated to and from the surveillance site. The surveillance site is where selected team members observe or survey the objective. Communication between the two sites is by wire, FM, or messenger.*

**E-1. TYPES OF HIDE AND SURVEILLANCE SITES**

The type of hide or surveillance site employed depends on METT-T. Improvement of camouflage, at a minimum, must be continuous while occupying the site. The enemy situation may not allow a team to improve from a surface site to a subsurface site.

a. **Surface Site.** (See Figure E-1, page E-4.)

(1) *Advantages.*

- Easy to construct.
- Requires minimal materials.
- Can be done quickly and quietly.
- No large amounts of soil need to be relocated.
- Stand-off capable optics are used to provide the security that is lost due to less camouflage.
- Surveillance team can escape quickly.

(2) *Disadvantages.*

- Little protection from small-arms weapons fire.
- No protection from indirect fires or NBC.
- Risk of compromise by dogs, civilians, and enemy patrols.

(3) *Construction materials.*

- Poncho(s) (waterproof).
- Yetti or camouflage net.  
(Prevents reflection of poncho; aids in camouflage.)
- 550-pound cord or bungee cord.
- Chicken wire (optional).
- Burlap or canvas cloth (optional).

(4) *Considerations for surface site.*

(a) Team members avoid cutting any vegetation. They use man-made or natural camouflage.

(b) Team members keep all equipment packed when not in use.

(c) Team members always stay in uniform. They do not remove load-carving equipment.

(d) Security is maintained 24 hours a day.

(e) Two to three team members may occupy a surveillance site. With three team members, they can stay longer, and one team member can rest. However, the site is larger and harder to conceal.

(f) The best time to switch surveillance teams is just after dark and just before daylight.

(g) Communication is setup between the hide site and the surveillance site.

(h) Team members take rucksacks to the surveillance site.

(i) In some situations, surveillance of the objective may only be done during limited visibility; the team stays in the hide site during the day.

(j) The surveillance site has all-round coverage, with nets or natural camouflage so it cannot be seen from any angle to include overhead.

(k) Distance between the hide site, the surveillance site, and the communication site (if used) depends on METT-T. Terrain should be the main factor.

(1) The team changes directions when moving from the hide site to the surveillance site, when possible (dog leg, fish hook, or indirect route).

(m) The team does not wear gillie suits (at least two per team) during movement. Pieces of the suit will rip off in vegetation and leave a trail. The soldiers put the suits on just before occupying the surveillance site.

**b. Hasty Subsurface Site.** A hasty subsurface site is constructed when there is not enough time to construct a complete subsurface site. The site is especially useful when there is little natural cover and concealment. The site is planned so that it can be improved to a full subsurface site as time and the situation allows. (See Figures E-1 through E-3, pages E-4 through E-6.)

(1) *Advantages.*

- Lower profile than surface surveillance site.
- Better protection against small-arms weapons and indirect fires.
- Excellent camouflage.

(2) *Disadvantages.*

- Limited construction tools.
- Soil must be concealed.
- Requires more time to construct.
- Construction noise.

(3) *Construction materials.*

- Ponchos or other waterproofing.
- Yetti net or small camouflage net to assist in camouflage.
- Entrenching tool.
- 550-pound cord or bungee cord.
- Chicken wire (optional).
- Burlap or canvas (optional).
- Sandbags.
- PVC pipe with connectors.
- Fiberglass rod.
- Aluminum conduit.
- Plywood.

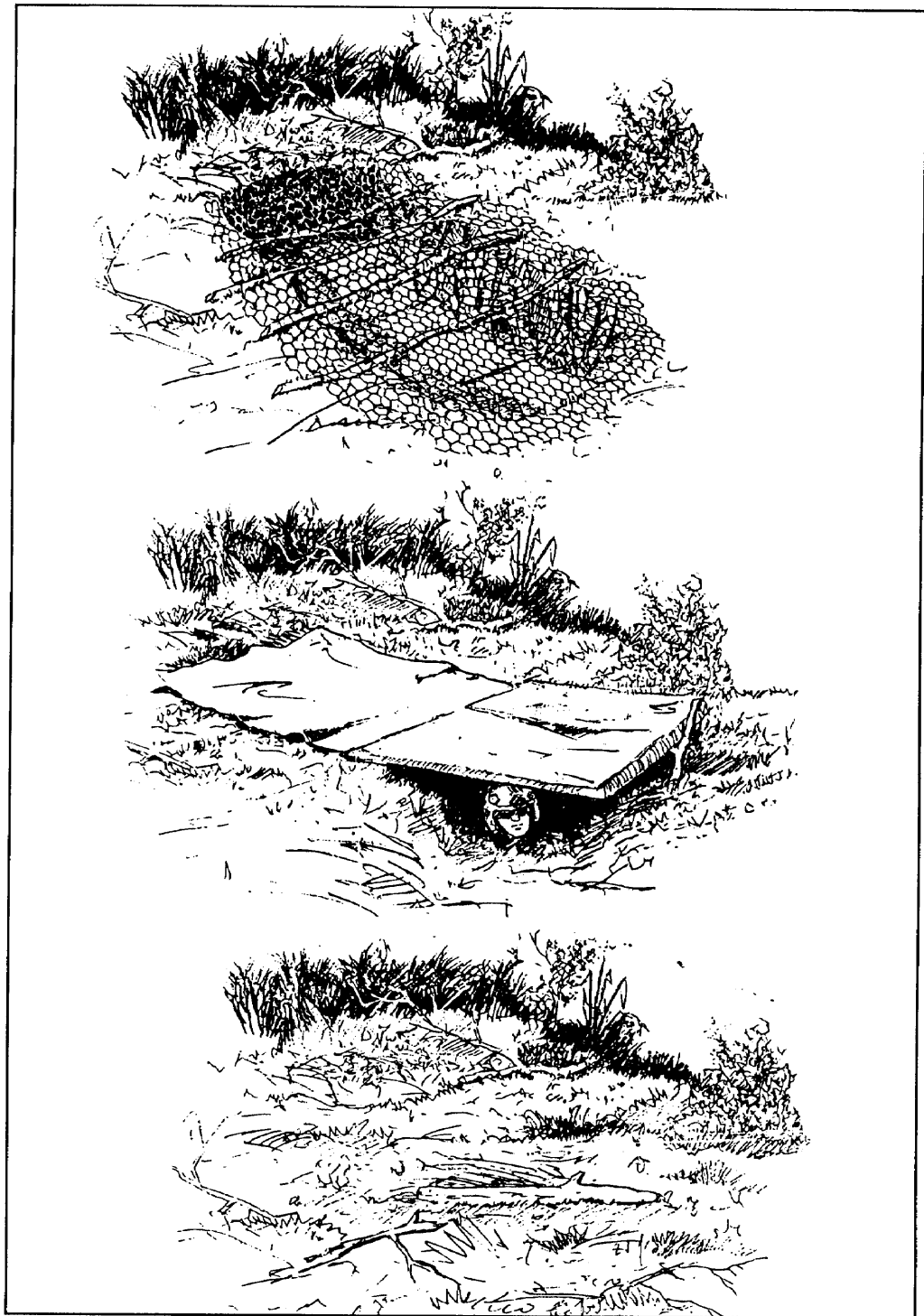

**Figure E-1. One-man surface site.**

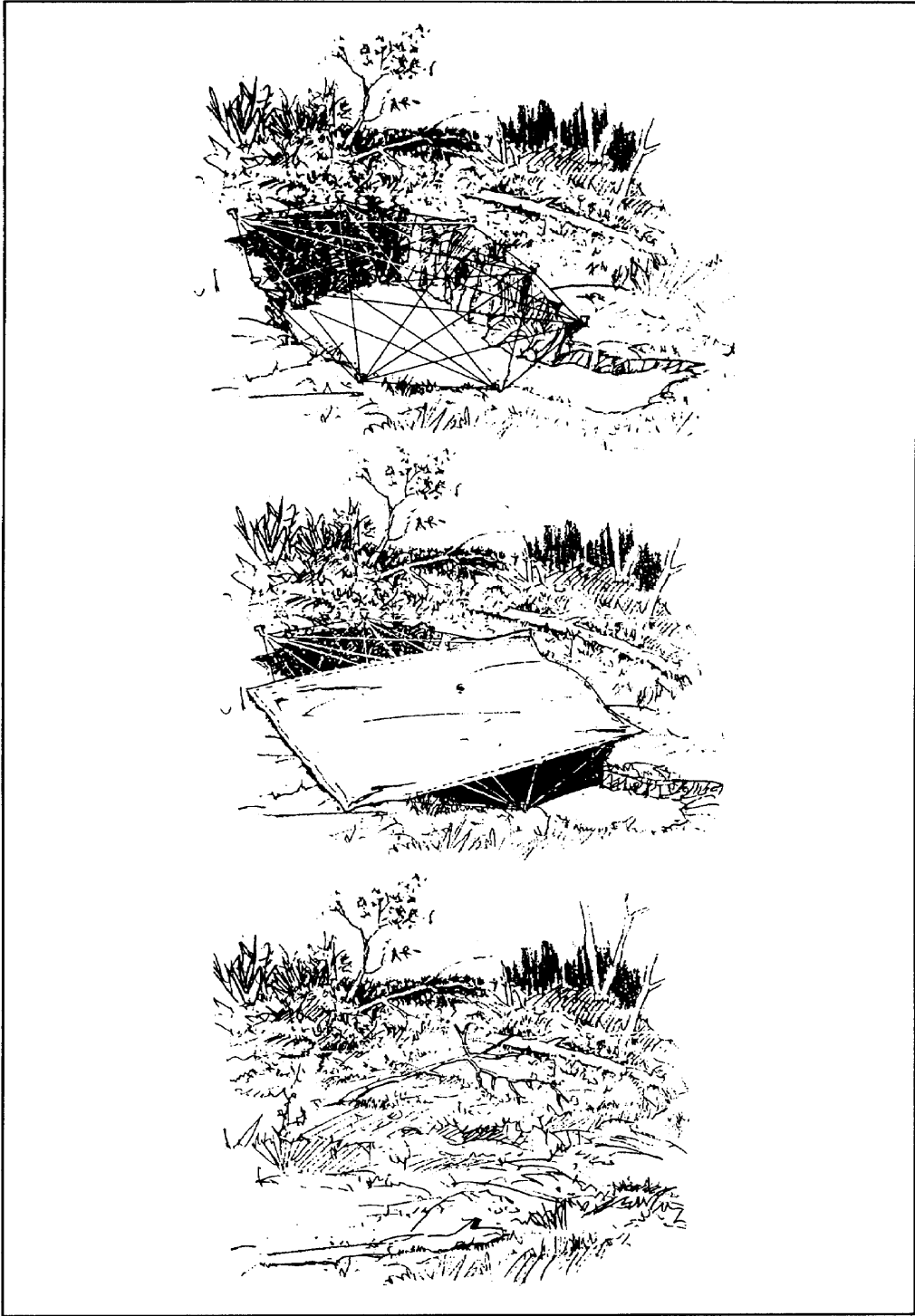

Figure E-2. Suspension line weaved site.



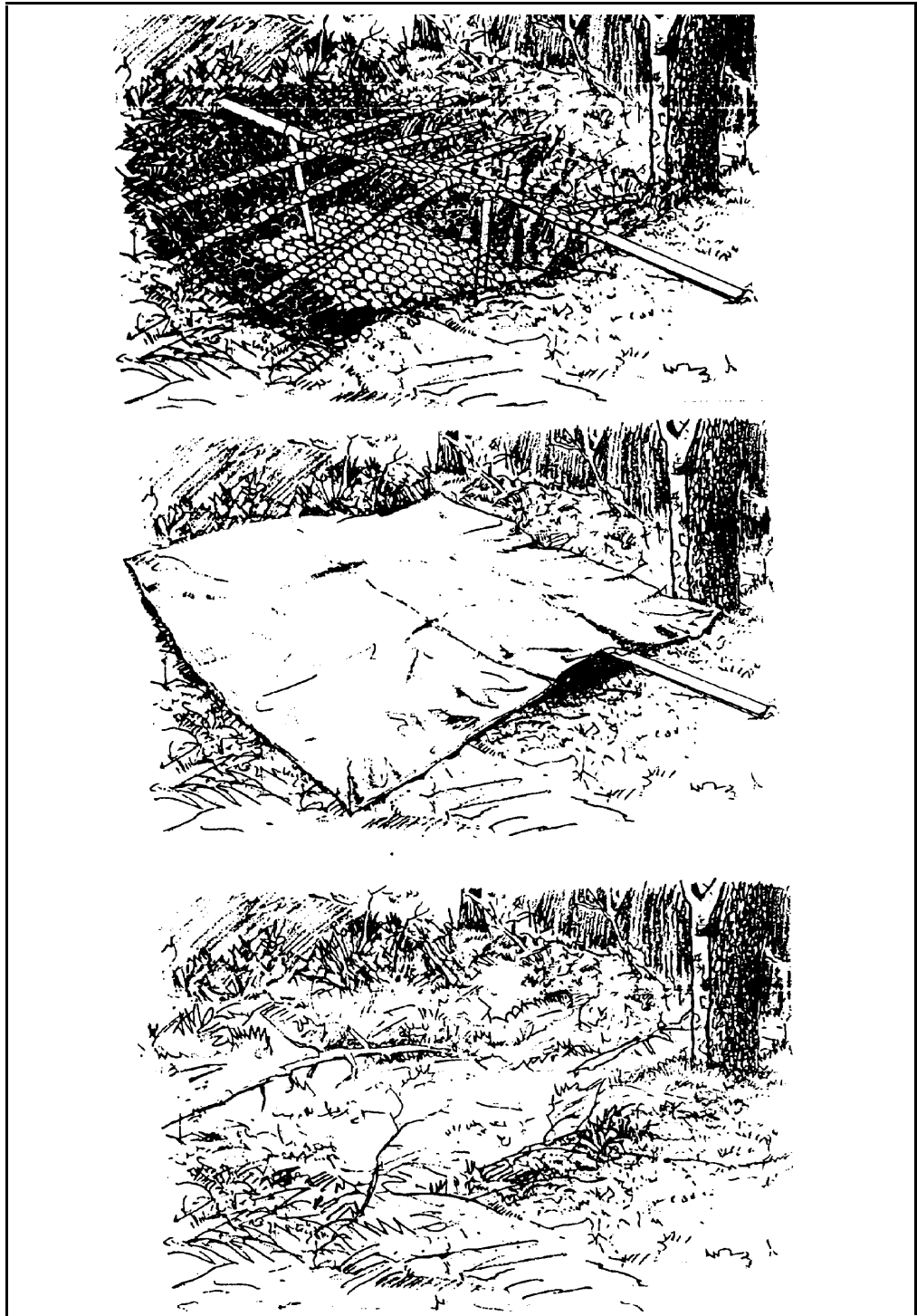

Figure E-3. PVC site.

c. **Subsurface Site.** Teams will be underground for a long time. The site must be large enough to accommodate the entire team. The site should be dug in a well-concealed area, away from enemy observation. The site may be dug and stocked with rations, water, ammunitions, batteries, and so on. Equipment, such as rucksacks and communications equipment, should be arranged so that a fast exit can be made in an emergency. A primary entrance and exit and an emergency entrance and exit should be built in the hide site. If the enemy should find the primary entrance, some type of deception should be made at that entrance and the emergency exit should be used. The team should have an SOP for leaving a subsurface site. If surveillance is done from the site, leaving the site depends on where the site is in relation to an enemy objective or on the terrain in which it is located. The basic design for the site is for a stay-behind mission. (See Figure E-4, page E-8.)

- The site must have enough room for the team to move around freely.
- The entrance and exits are covered and concealed.
- The top of the site should be strong enough so that personnel can walk on it.
- Dirt is removed from the site in rucksacks, sandbags, socks, or anything that can be used as a container. Most of the dirt is placed back on the top.
- The team camouflages the leftover dirt. They look for natural depressions, remove the top cover, fill in the depression, and recamouflage, or use streams or waterways during heavy rains. They avoid populated areas as much as possible.
- The team camouflages the site during construction by using yetti nets with camouflage material, natural camouflage, or chicken wire with camouflage material.
- The team removes waste by using ziplock bags; meals, ready-to-eat bags; or anything that can be used as a container. They can use a meals, ready-to-eat box with trash bag as a toilet or a portable camping toilet. They have a bag of lime or baking soda to cover the odor.

- A barricade is built to provide shelter.
  - Sleeping positions should be separate and comfortable.
  - Soldiers do not remove their load-carrying equipment.
  - Shovels are disassembled and carried in rucksacks.
- (1) *Advantages.*
- Little risk of compromise.
  - Protection from artillery and small-arms weapons fire.
  - Protection from nuclear attack.
  - Excellent camouflage.
- (2) *Disadvantages.*
- Requires considerable time to construct.
  - Soil must be concealed away from the site.
  - Construction noise.
  - Manpower, material, and equipment required to construct.
- (3) *Construction materials (dependent on design).*
- Fifty 2-inch by 4-inch by 12-foot boards; six 4-inch by 4-inch by 6-foot boards.
  - Gravel to cover floor.
  - Eighteen inches of overhead cover over entire site.
  - Backhoe or soldiers with shovels.
  - One-hundred sandbags.
  - General-purpose large tent to cover digging operations until complete.

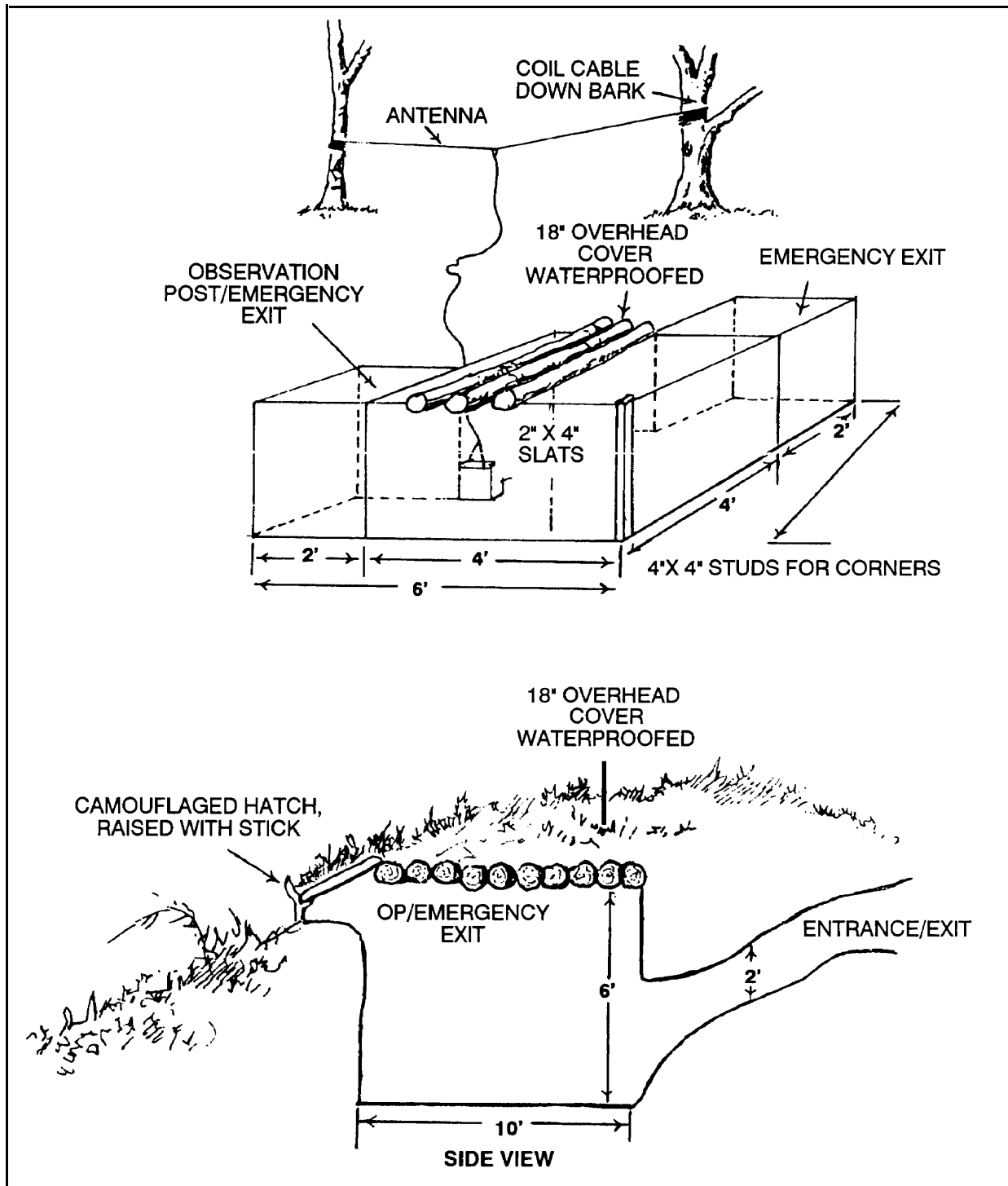

Figure E-4. Example of subsurface site.

## **E-2. SITE SELECTION CONSIDERATIONS**

When selecting a site, the leader should consider the following aspects:

- Line of sight to target.
- Within a range that can be supported by available observation equipment to meet the reporting requirements.
- Overhead concealment and cover.
- Away from natural lines of drift.
- Away from roads, trails, railroad tracks, and major waterways.
- Defendable for a short time.
- Primary and alternate hasty exits.
- Concealed serviceable entrance; little noise getting into and out of the hide site.
- METT-T in relation to other site positions (hide, surveillance, communication sites).
- Not near man-made objects.
- Downwind of inhabited areas.
- Not dominated by high ground, but takes advantage of the high ground.

## **E-3. LEADER'S RECONNAISSANCE**

The team leader initially selects the tentative sites during the planning phase. He selects the sites by physical reconnaissance (stay-behind), aerial observation, photographs, line-of-site data, soil and drainage data, or map reconnaissance. At a minimum, the team leader selects primary and alternate hide sites, and primary and alternate surveillance sites. Before the team occupies the sites, the team leader conducts a physical reconnaissance of the tentative site chosen during planning. If necessary, the team leader moves the site to a better location.

## **E-4. OCCUPATION OF THE HIDE SITE**

When occupying the hide site, the leader has several methods he can select.

a. **Fishhook or Dog-Leg Method.** These methods are done from the direction of march. (See Figure E-5.)

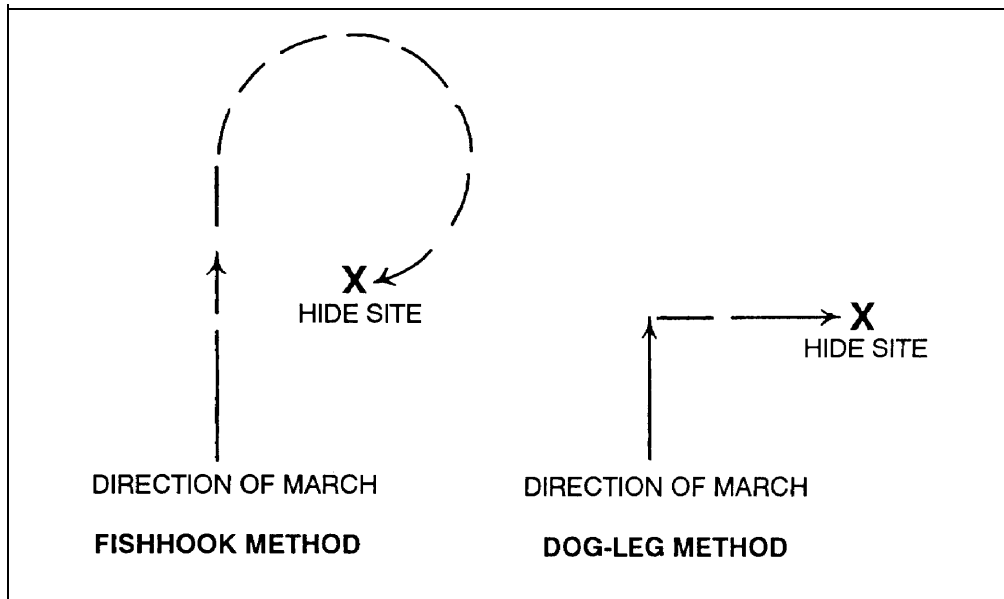

Figure E-5. Fishhook and dog-leg methods.

b. **Occupation by Force.** Occupation by force occurs as a last resort, usually when time is a major limiting factor. In this case, a leader's reconnaissance is conducted and the team moves directly into the tentative site. (See Figure E-6.)

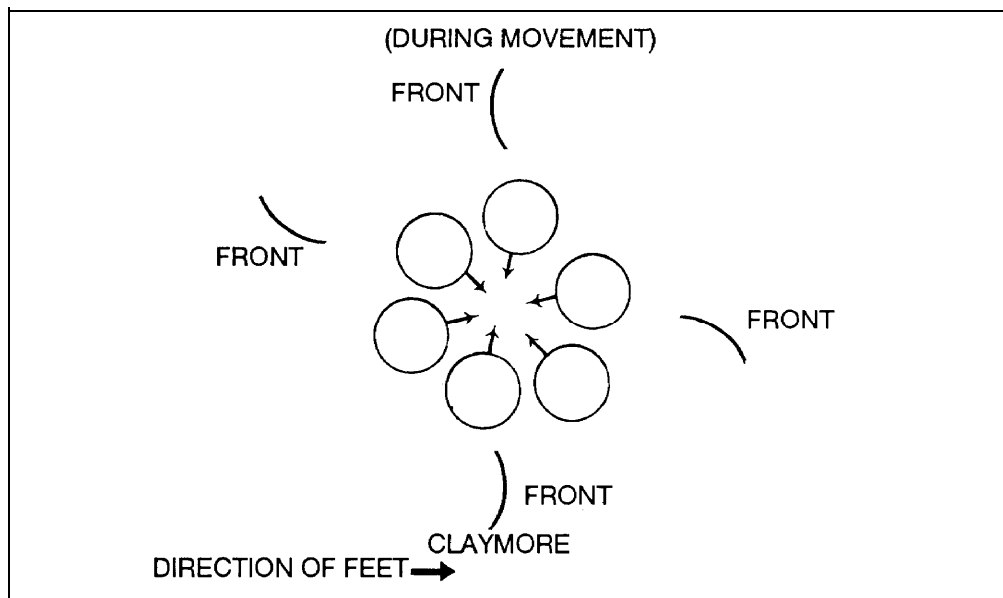

Figure E-6. Site occupation.

### **E-5. ACTIONS IN THE HIDE SITE**

The team maintains security at all times. Soldiers are positioned either back-to-back or feet-to-feet, using all-round security.

a. The team waits 15 minutes before moving or unpacking equipment, using time as a listening halt. They do not lean against small trees or vegetation. They place Claymores, at least, in the four cardinal directions.

b. If communication is to be conducted from the hide site, the antenna is constructed before dark. The antenna is not raised off the ground until communication is established. This reduces the amount of noise and movement at night.

c. Team members wear their load-carrying equipment at all times. They camouflage all-round the position.

d. The best time to rotate teams is at dusk and dawn. The surveillance team takes their rucksacks or assault packs. The team rests during the day.

### **E-6. PRIORITY OF WORK**

Work priorities may vary, depending on the factors of METT-T, with the exception of security. The team has security, alert, evacuation, and rendezvous plans. The team conducts stand-to starting before first light and continue it until after full light. They conduct stand-to starting before dark and continue it until after dark. They vary the starting times to keep from setting a pattern. They select and reconnoiter alternate hide and surveillance sites. They maintain equipment, radios, weapons, and camouflage. They ensure to perform personal hygiene and preventive medicine. They conduct isometric exercises. They have a meal plan. They prepare guard and rest plans.

### **E-7. SITE STERILIZATION**

Before departing hide and surveillance locations, team members must ensure sites and routes have been sterilized.

a. Personnel carry out all foreign debris.

b. If possible, they do not bury waste or trash. Animals will uncover trash and expose it to enemy patrols. If trash is buried, the team buries it 18 to 24 inches deep in sealed containers or covers the scent by using CS or lime.

c. The team sterilizes the sites using displaced earth. They use the site to bury overhead material, which contrasts with the surrounding area.

d. The team camouflages the area by blending the site with local surroundings.

e. As team members withdraw from the site, they ensure routes are camouflaged to prevent detection.

## APPENDIX F

**TRACKING AND COUNTERTRACKING, EVASION AND ESCAPE, AND SURVIVAL**

*Tracking and countertracking evasion and escape, and survival involve skills and techniques that can be crucial to an LRS team during a mission beyond the forward line of own troops. LRS teams may find that they are being tracked during the course of a mission. Additionally, they may encounter tracks or signs during movement or during a surveillance mission. To be an effective countertracker and to provide intelligence on the frequency and flow of traffic on trails, an LRS soldier must be an effective tracker.*

**F-1. TRACKING AND COUNTERTRACKING**

Operating deep behind enemy lines requires proficiency in tracking and countertracking skills. Tracking ability allows an LRS team to immediately identify the presence of the enemy and collect intelligence. Tracking is also useful when an LRS team conducts a combat search and rescue mission to retrieve a downed pilot. Additionally, knowing how to track greatly enhances the team's ability to countertrack.

a. **Concepts of Tracking.** To become a tracker, certain qualities must be developed and refined such as patience, persistence, acute observation, good memory, and intuition. These traits help when the tracking signs become weak or if the tracker has a certain feeling about the situation. As the tracker moves, he forms an opinion about the enemy such as how many, degree of training, the equipment they have, and state of morale. The following six indicators help form the tracker's picture of the enemy.

(1) *Displacement.* Displacement means that something is moved from its original position. The tracker looks for signs of displacement for 10 to 15 meters in a 180-degree arc to his front from the ground to the average height of a man. (See Figure F-1, page F-2.) By comparing indicators, the tracker can gain information. For example, if a footprint is found and a scuff mark on a tree is about waist high, it may indicate that an armed soldier passed this spot. (See Figure F-2, page F-2.) A footprint can tell the tracker what footwear the enemy is wearing, if any. It can also show the lack of proper equipment, the direction of movement, number of persons, whether they are carrying heavy loads, the sex, rate of movement, and whether or not they know they are being followed. (See Figure F-3, page F-3; see Figure F-4, page F-4.) Other forms of displacement are bits of clothing or thread left on the ground or vegetation. Movement of vegetation on a still day (such as broken limbs and bent grass, animals flushed from their homes or cries of excitement; trails cut through foliage, disturbed insect life, or turned over rocks) indicates a presence.



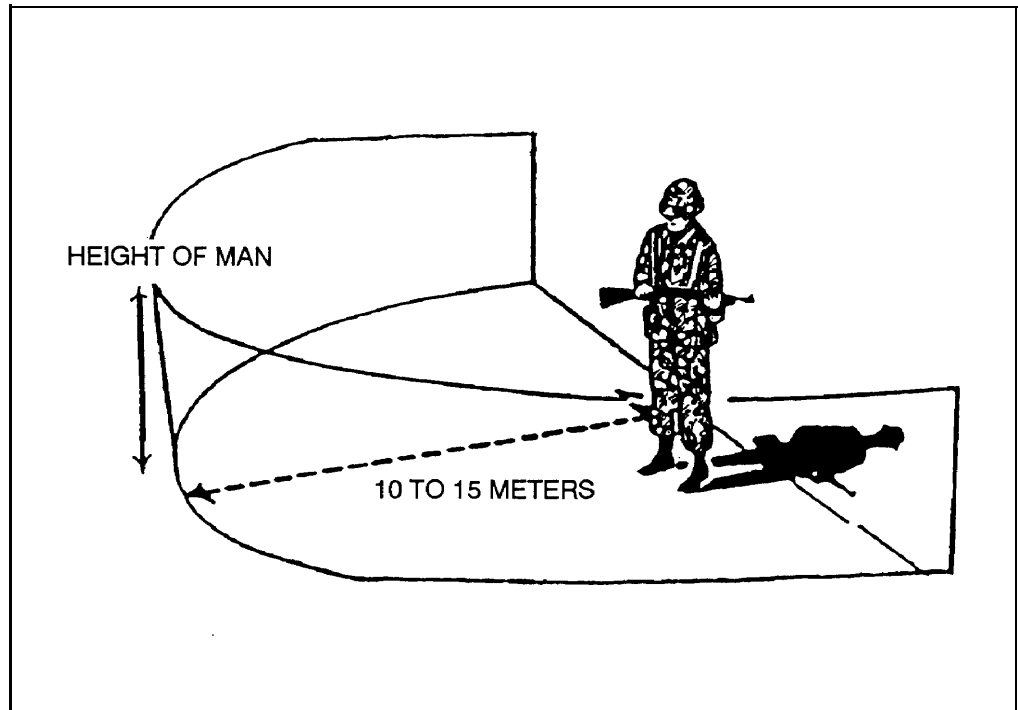
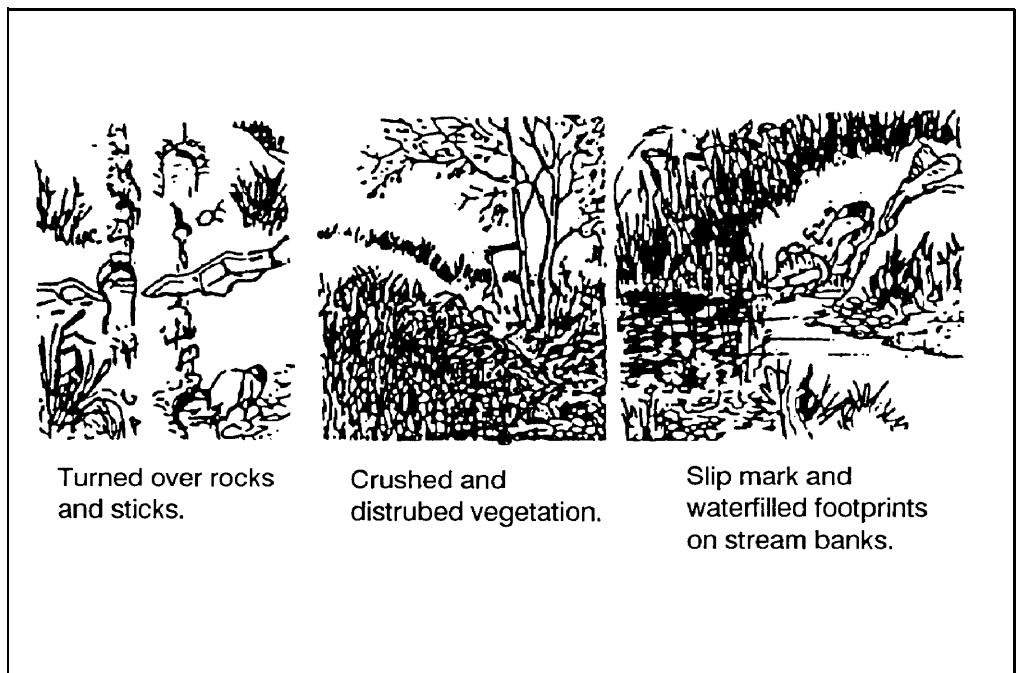

Figure F-1. Area surveyed for indicators by tracker.



Turned over rocks and sticks.

Crushed and disturbed vegetation.

Slip mark and waterfilled footprints on stream banks.

Figure F-2. Examples of displacement.

If the footprints are deep and the pace is long, the party is moving rapidly. Long strides and deep prints, with toe prints deeper than heel prints, indicate that the party is running.

If the prints are deep, short, and widely spaced, with signs of scuffing or shuffling, a heavy load is probably being carried by the party.

To determine the sex of the party being followed, the size and position of the footprints are studied. Women generally tend to be pigeon-toed, while men usually walk with their feet pointed straight ahead or slightly to the outside. Women's prints are usually smaller and their strides are usually shorter than men's.

If a party knows that it is being followed, it may attempt to hide its tracks. Persons walking backward have a short, irregular stride. The prints have an unusually deep toe. The soil will be kicked in the direction of movement.

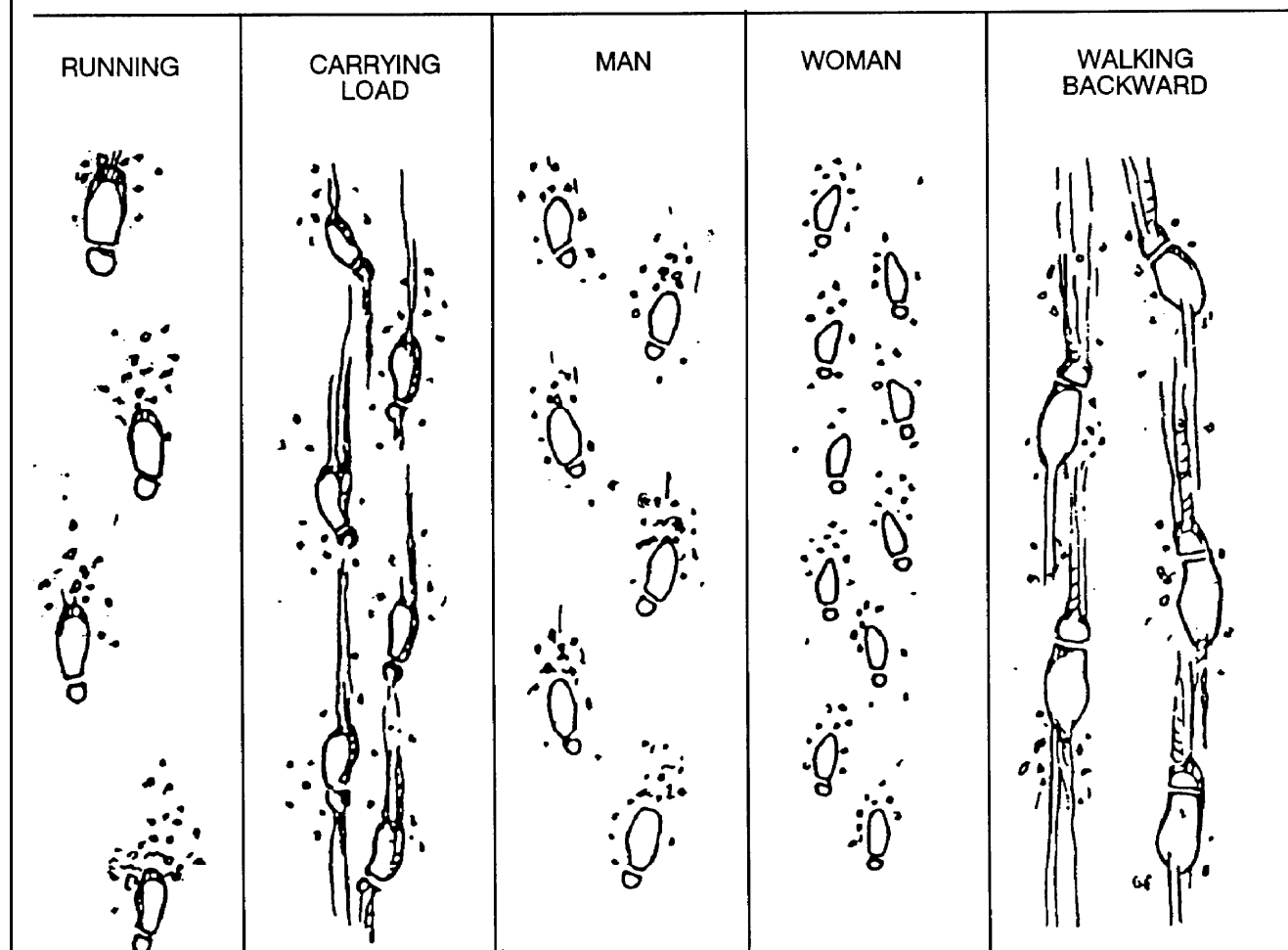

Figure F-3. Types of footprints.

To use the 36-inch box method, mark off a 30- to 36-inch cross section of the trail, count the prints in the box, then divide by two to determine the number of persons that used the trail. (The M16 rifle is 39 inches long and may be used as a measuring device.)

Identify a key print. In this case, it is the left boot print. Draw a line from the heel across the trail. Then, move forward to the key print of the opposite foot and draw a line through the instep. This should form a box with the edges of the trail forming two sides, and the drawn lines forming the other two sides. Next, count every print or partial print inside the box to determine the number of persons. Any person walking normally would have stepped in the box at least one time.

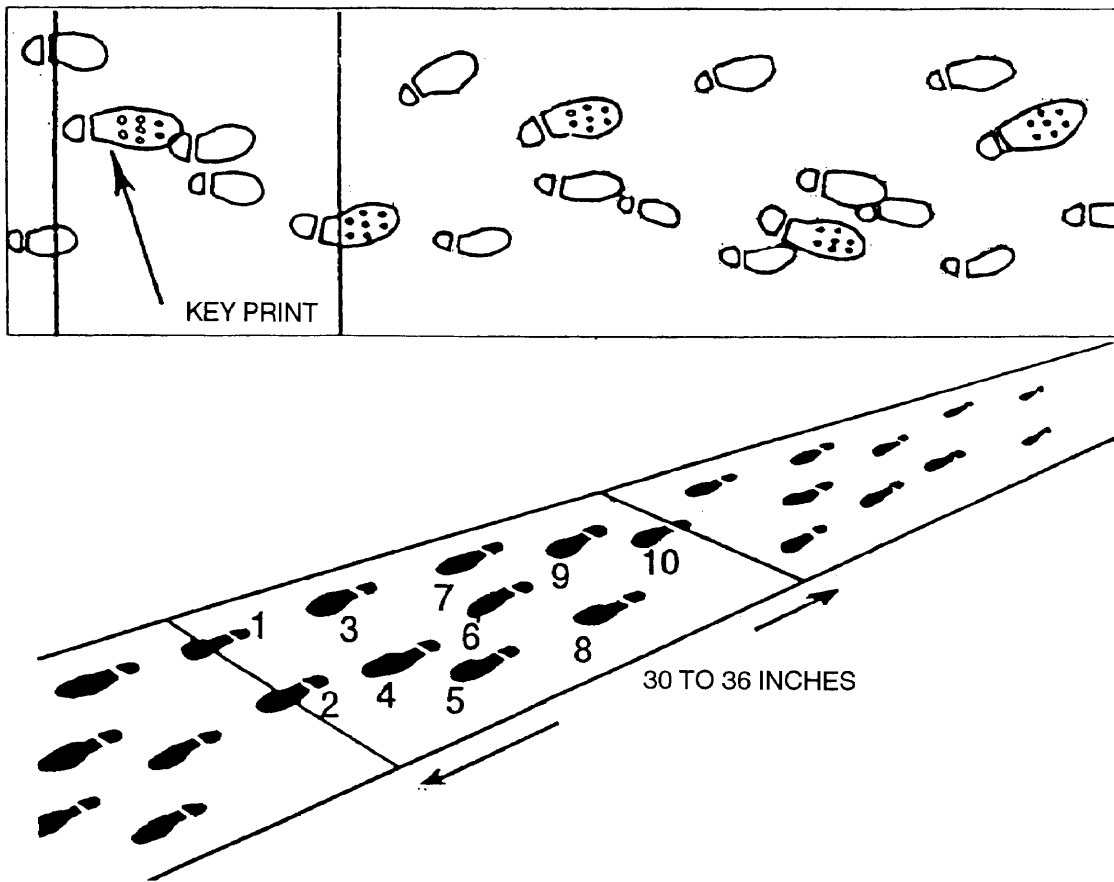

Figure F-4. Box method for determining number of footprints.

(2) *Staining.* A good example of staining is blood on the ground or foliage. Other examples of staining are mud dragged by footgear and crushed vegetation on a hard object. Crushed berries also stain. The movement of water causes it to become cloudy.

(3) *Weathering.* The weather may help or hinder the tracker to determine the age of signs. Wind, snow, rain, and sunlight are factors affecting tracking signs.

(4) *Littering.* A poorly disciplined unit will pass through an area leaving a path of litter. A tracker can use the last rain or strong wind as a measure to show the amount of time it has been there.

(5) *Camouflaging techniques.* Camouflage applies to tracking when the followed party tries to slowdown the tracker; for example, leaving footprints walking backward, brushing out trails, and walking over rocky ground or through streams are ways of camouflaging the trail.

(6) *Interpreting combat information.* The tracker makes a mental image of who he is tracking by using his learned concepts. When reporting to the commander, he indicates what he believes, but should not state it as fact. Commanders take this information under consideration. If they choose, immediate planning is done to take action against the enemy.

**b. Tracking Team Organization.** Tracking units can be any size as long as they have these three elements: a leader, a tracker, and security. Often, tracking teams consist of two types:

(1) *Tracker and cover man.* Each team member is equally skilled. They can move fast, know each other's abilities and weaknesses, and can compensate for each other.

(2) *Tracking team leader tracker RATELO, and two security men.* The advantages of a tracking team with this many members are increased observation and security. The disadvantage is the size of the team.

**c. Tracker and Dog Teams.** Tracker and dog teams are more effective than a tracker alone.

(1) *Dog characteristics.* The dog(s) follows a trail faster and can continue to track at night. Despite years of domestication, dogs retain most of the traits of their wild ancestors. If put to controlled use, these traits are effective when tracking.

(a) *Endurance.* A dog can hold a steady pace and effectively track for up to eight hours. The speed can be up to 10 miles per hour, only limited by the speed of the handler. The speed and endurance can be further increased by the use of vehicles and extra teams.

(b) *Mental characteristics.* Dogs are curious by nature. Dogs can be aggressive or lazy, cowardly or brave. A dog's sensory traits are what make him seem intelligent.

(c) Aggressiveness. Tracking dogs are screened and trained. They are aggressive trackers and eager to please their handler.

(d) Sensory characteristics. Knowledge of the following sensory traits and how the dog uses them helps the evader to think ahead of the dog.

- Sight. A dog's vision is the lesser of the sensing abilities. They see in black and white and have difficulty spotting static objects at more than 50 yards. Dogs can spot moving objects at considerable distances, however, they do not look up unless they are training up a tree. A dog's night vision is no better than man's.
- Hearing. A dangerous problem for the evader is the dog's ability to hear. Dogs can hear quieter and higher frequencies than humans. Even more dangerous is their ability to locate the source of the sound. Dogs can hear 40 times better than men.
- Smell. The dog's sense of smell is about 900 times better than a human. It is by far the greatest asset and largest threat to the evader. Dogs can detect minute substances of disturbance on the ground or even in the air. Using distracting or irritating odors (for example, CS powder or pepper) only bothers the dog for a short time (3 to 5 minutes). After the odor is discharged by the dog, he can pickup a cold trail even quicker. The dog smells odors from the ground and air and forms scent pictures. The scent pictures are put together through several sources of smell.
  - Individual scent. This is the most important scent when it comes to tracking. Vapors horn body secretions work their way through the evader's shoes onto the ground. Sweat from other parts of the body rubs off onto vegetation and other objects. Scent is even left in the air.
  - Reinforcing scent. Objects are introduced to the dog that reinforce the scent as it relates to the evader. Some reinforcing scents could be on the evader's clothing or boots, or the same material as is used in his clothing. Even boot polish can help the dog.
  - Ecological scent. For the dog, the most important scent comes from the earth itself. By far, the strongest smells come from disturbances in ecology such as crushed insects, bruised vegetation, and broken ground. Over varied terrain, dogs can smell particles and vapors that are constantly carried by the evader wherever he walks.

(2) *Favorable tracking conditions.* Seldom will the conditions be ideal for the tracker and dog teams. During training, they become familiar with the difficulties they will face and learn to deal with them. The following conditions are favorable for tracker and dog teams.

(a) Fresh scent. This is probably the most important factor for tracker teams. The fresher the scent, the greater chances of success.

(b) Verified starting point. If trackers have a definite scent to introduce to the dogs, it helps the dogs to follow the correct trail.

(c) Unclean evader. An unclean evader leaves a more distinctive scent.

(d) Fast-moving evader. A fast-moving evader causes more ground disturbances and individual scent from sweat.

(e) Night and early morning. The air is thicker and the scent lasts longer.

(f) Cool, cloudy weather. This limits evaporation of scent.

(g) No wind. This keeps the scent close to the ground. It also keeps it from spreading around, allowing the dog to follow the correct route.

(h) Thick vegetation. This restricts the dissemination of scent and holds the smell.

(3) *Unfavorable tracking conditions.* Marked loss in technique proficiency can be expected when the following conditions occur.

(a) Heat. This causes rapid evaporation of scent.

(b) Unverified start point. The dogs may follow the wrong route or scent.

(c) Low humidity. Scent does not last as long.

(d) Dry ground. Dry ground does not retain scent.

(e) Wind. Wind disperses scent and causes the dog to track downwind.

(f) Heavy rain. This washes the scent away.

(g) Distractive scents. These take the dog's attention away from the trail. Some of these scents are blood, meat, manure, farmland, and populated areas.

(h) Covered scent. Some elements in nature cause the scent picture to be partially or completely covered. Examples are sand that can blow over the tracks and help to disguise the track; snow and ice that can form over the track and make it nearly impossible to follow; and water. Water is one of the most difficult conditions for a tracker dog team. Water that is shallow, especially if rocks or vegetation protrude, can produce a trail that a dog can follow with varied degrees of success.

c. **Countertracking.** Countertracking techniques are constantly used by LRS teams to avoid alerting the enemy to their presence. To be effective at evading trackers, countertracking techniques must be known. Knowledge of

tracking is probably the best way to successfully evade trackers. Knowledge of tracker and dog teams greatly assists the survivor when evading the enemy. Some of the following techniques may throw off trackers:

- Double back (especially when moving into open areas).
- Use trails (follow or pretend to follow, then double back).
- Walk backward (this makes the tracker believe the evader is moving in the opposite direction).
- Change directions before entering streams.
- Walk in water.
- Cover the trail.
- Outdistance trackers.
- Take advantage of terrain and weather conditions; for example, use streams and sparsely vegetated areas to move through, and move during heavy rains.

## **F-2. EVASION AND ESCAPE**

Evasion is eluding the enemy during a mission or following contact. Escape is breaking away from the enemy when surrounded. Together, evasion and escape refer to the act of returning to friendly lines by foot, essentially escaping from the enemy and evading him to reach friendly lines. (See FM 90-18 for more information on evasion.)

a. **Short- and Long-Range.** In short-range evasion, the evader is close to the main battle area and becomes isolated from his unit. He usually has the means to return to the unit within a few days. Long-range evasion involves greater distances behind enemy lines where the evader may have to travel miles over foreign terrain, possibly with little food and equipment. LRS teams fit into this group. Characteristics of successful long-range evasions include—

- Being able to cover greater distance from friendly forces.
- Knowing survival techniques.
- Knowing travel restrictions are greater.
- Conserving supply.
- Having a strong will to survive: sense of responsibility (the strong help the weak), family and home ties, panic control, continuous planning, patience and endurance, self-preservation, and knowledge of survival and evasion.

- 
- Knowing special considerations: where to go; attitude of the population; customs of the people; advantages and disadvantages of civilian contact; travel restrictions, curfews, checkpoints, and roadblocks.
  - Knowing available courses of action: exfiltrations, deceptions. At times, it is impossible to travel without coming in contact with civilians. Evasion by deception under these circumstances is necessary. Deception may require the use of a disguise and a cover story. Deception is perhaps the most difficult type of evasion to take. A combination of exfiltration and deception may apply in some situations.
  - Collecting information.

b. **Principles.** The following basic principles area must for the team to be successful at evasion:

- A detailed plan, including how to evade the enemy (take time, conserve food and strength by resting and by sleeping when needed), survive, and return to friendly territory.
- Rules of engagement including camouflage and concealment.

(1) *General evasion.* When a soldier becomes isolated and is unable to return to his unit or is unable to continue his assigned mission, he must find a safe hiding place where he can make an estimate of the situation and plan his courses of action. He considers the following.

(a) Travel. Travel is critical for the evader because chances of capture are greater, while on the move. Some planning considerations are—

- Avoid major roads and populated areas.
- Always use camouflage and concealment.
- Use a disguise as much as possible.
- When possible, travel during darkness. However, if it is likely that the enemy or local civilians know the location, move immediately. Whenever possible, the terrain to be traversed at night should be observed during the day. Be especially attentive to concealment and to obstacles in the travel path.
- Use maps and shelter.
- Measure progress on the ground by the stopover points that are reached. Speed and distance are secondary. Do not let failure to meet a precise schedule inhibit the use of a plan.



(b) Obstacles. Obstacles can impede or influence the selection of travel routes. Obstacles are in two categories: natural and man-made.

- Natural obstacles are rivers, streams, and mountains.
- Man-made obstacles include electric fences, contaminated areas, border and front-line crossings, friendly teams, and friendly outposts.

(2) *Assisted evasion*. Behind enemy lines, there may be people who are dissatisfied with the existing condition of the country. They may assist in a number of ways. One of the ways that these individuals may contribute is in establishing an evasion and escape system for allied evaders to return to friendly territory. This type of evasion is designated in the OPOD or communicated to a team by HF radio during the conduct of a mission. The team avoids contact with personnel during an evasion and escape, unless instructed to do so.

(a) Evasion and escape lines. These are organized to contact, secure, and evacuate friendly personnel. They may provide the following assistance:

- Shelter, food, equipment, clothes, and credentials acceptable to the area.
- Information on the enemy.
- Guides and medical treatment, plus local currency and transportation.

(b) Aids. Some aids to assist the evader to return to friendly lines are—

- Blood chit. The blood chit is a small cloth depicting the American flag and a statement in several languages. It identifies the bearer as a member of the US forces and promises a reward for the bearer's safe return to US control.
- Pointee talkee. The "pointee talkee" is a language aid that contains selected English phrases on one side of the page. The foreign language translation is on the other side. The soldier determines the question or statement to be used in English, then points to its foreign language counterpart.

(c) Conduct of evasion and escape lines. Evasion and escape lines includes contacting the line. The following actions must be considered when contacting the line, approaching the line, making contact with the line, and procedures after making contact.

- Establishing identity. During planning, all team members complete a DD Form 1833, Isolated Personnel Report (ISOPREP) (see Figure F-5.)

CONFIDENTIAL (WHEN FILLED IN)

<b>ISOLATED PERSONNEL REPORT (ISOPREP)</b> <i>(See Privacy Act Statement on reverse before completing this form)</i>		<b>1. NAME (Last, First, Middle Initial)</b> GOODE, JOHNNY B.		<b>2. SSN</b> 123-45-6789	
<b>CLASSIFIED BY: AFR 64-3, AR 525-90 NWP 19-2</b> <b>DECLASSIFY ON: OADR</b>		<b>INSTRUCTIONS</b> Items 1 through 15 and 20 through 23 are to be completed by Applicant. Items 16 through 19 and Item 24 are to be completed by RCC Personnel. All items are to be filled in INK; however, use a PENCIL for items 3, 13, 14, and 20 through 24.			<b>3. RANK/GRADE</b> LTC/05
<b>4. BRANCH OF SERVICE</b> US Army		<b>5. NATIONALITY</b> American	<b>6. DATE OF BIRTH (YYMMDD)</b> 540131	<b>7. OBVIOUS MARKS (Scar, Birthmark, Mole)</b> NONE	
<b>8. BLOOD GROUP</b> O+		<b>9. HEIGHT</b> 6'4"	<b>10. COLOR OF EYES</b> Blue	<b>11. COLOR OF HAIR</b> Blonde	
<b>12. DATE PREPARED (YYMMDD)</b> 931006		<b>13. DATE REVIEWED (YYMMDD) AND CURRENT ASSIGNMENT</b> 931201	<b>14. AUTHENTICATOR NO.</b> 0613		<b>15. SIGNATURE</b>
<b>16. DATE MISSING (YYMMDD)</b> (RCC personnel will complete.)		<b>17. LOSS POSITION</b> (RCC personnel will complete.)	<b>18. PRIORITY (Holds vital information requiring priority rescue)</b> (RCC personnel will complete.) <input type="checkbox"/> YES <input type="checkbox"/> NO	<b>19. SPARE</b> (RCC personnel will complete.)	
----- Fold here -----					
<b>PERSONAL AUTHENTICATION STATEMENTS</b>					
<b>20.</b> (Use declarative statements, not questions you can easily remember and that are not relatives [other than immediate family], private. Avoid references to dates, ages, records or public information. These derive four questions from each statement			<b>21.</b> and answers. Give personal details that subject to change. Details of friends, pets, vehicles, and vacations are appropriate. Information from your military statements should be detailed enough to to authenticate the individual; for example		
<b>22.</b> "My first car was a green, four-door, 1941			<b>23.</b> Packard.")		
<b>24. ADDITIONAL DATA</b> (Do not complete. This block is for local use.)					

DD FORM 1833 PREVIOUS EDITION IS OBSOLETE  
 84 FEB

CONFIDENTIAL (WHEN FILLED IN)

Figure F-5. Example of DD Form 1833 (front).

CONFIDENTIAL (WHEN FILLED IN)

*AUTHORITY: 10 U.S.C. Sections 133, 3012, 5031 and 8012; EO 9397.  
 PRINCIPAL PURPOSE(S): It is essential to the combat search and rescue effort for the protection of search and rescue forces from enemy entrapment. The social security number is used to ensure positive identification.  
 ROUTINE USE(S): It will be completed by each aircrew member who may be subject to action in or over hostile territory. It contains personal information that may be used to ensure positive identification. After the aircrew member has completed the form it will be classified "CONFIDENTIAL."  
 DISCLOSURE IS VOLUNTARY: The information is necessary since it affects the entire search and rescue mission and effect on individual of not providing information could be loss of crew status.*

LEFT HAND	CODE	PRINT CODE	CODE	RIGHT HAND
1. LITTLE FINGER		Arch	KK	10. LITTLE FINGER
		Tented Arch	LL	
		Finger Loop	MM	
		Thumb Loop	NN	
		Whorl	OO	
2. RING		Finger Missing	PP	9. RING
		Finger Mutilated	QQ	
		Question/Uncertain	YY	
----- Fold here -----				
3. MIDDLE		PHOTOGRAPH (Front View)  (Provide current front photograph in normal flight clothing.)		8. MIDDLE
	4. INDEX		PHOTOGRAPH (Profile View)  (Provide current profile photograph in normal flight clothing.)	
5. THUMB				6. THUMB

DD FORM 1833, 84 FEB (REVERSE)

U.S. Government Printing Office: 1985-460-983/35042

CONFIDENTIAL (WHEN FILLED IN)

Figure F-5. Example of DD Form 1833 (back) (continued).

- Having patience while awaiting movement on the line.
- Obeying those assisting the evasion and escape.
- Planning for escape in case of compromise of the line.

(d) Traveling the line. The team considers the following in traveling the line—

- Planning and coordinating with fellow evaders and traveling with guides.
- Not speaking to strangers.
- Not showing personal articles and not offering payment to helpers.
- Having assisted evasion in the unconventional warfare operational areas. US Special Forces may also organize and operate evasion and escape mechanisms in assigned unconventional warfare operational areas.

c. **Evasion Planning.** The LRSU commander makes an initial assessment as to the area the team will most probably evade. He coordinates with the corps or division aviation units to determine if they have combat search and rescue plans that might coincide and be of use to the LRS team. If the aviation unit does have combat search and rescue plans in effect, the plans are used whenever possible. Finally, the commander identifies and coordinates with the joint combat search and rescue commander, normally at echelons above corps. If a team cannot be assisted in evasion at the corps or division level, all evasion planning information for that team, to include DD Form 1833, is given to the joint combat search and rescue commander. DD Form 1833 is critical for the team to enter an evasion network. (For more information on joint combat search and rescue planning and execution, see FM 90-18.)

d. **LRS Team Evasion Planning.** After the LRSU commander coordinates with other evasion planning agencies, he may determine the unit must make independent evasion plans. The LRSU commander starts by identifying the team evasion corridor. The corridor begins in the objective area and ends at a point the commander anticipates friendly forces will control at the end of the evasion.

(1) The commander may also identify designated areas of recovery along the corridor. However, the preferred method is for the team leader to designate the recovery areas based on his METT-T analysis. Designated areas of recovery are specific areas on the ground where exfiltration or linkup will occur. The team leader makes a determination as it applies to his

team and anticipates METT-T factors if the team must execute the evasion plan. Time intervals between recovery areas are planned; for example 24, 48, or 72 hours. This allows the LRSU commander to keep track of the team as it travels the evasion corridor. (Figure F-6.)

(2) The commander ensures the team fills out DD Form 1833. He provides the team with duress codes for all communication systems. He provides them with signals to use during the evasion for aerial recovery at designated areas of recovery. He also provides signals to use in case of indigenous or partisan linkup. He gives the team the timetable to schedule recovery areas for activation. An example of a timetable is in Figure F-7, page F-16.

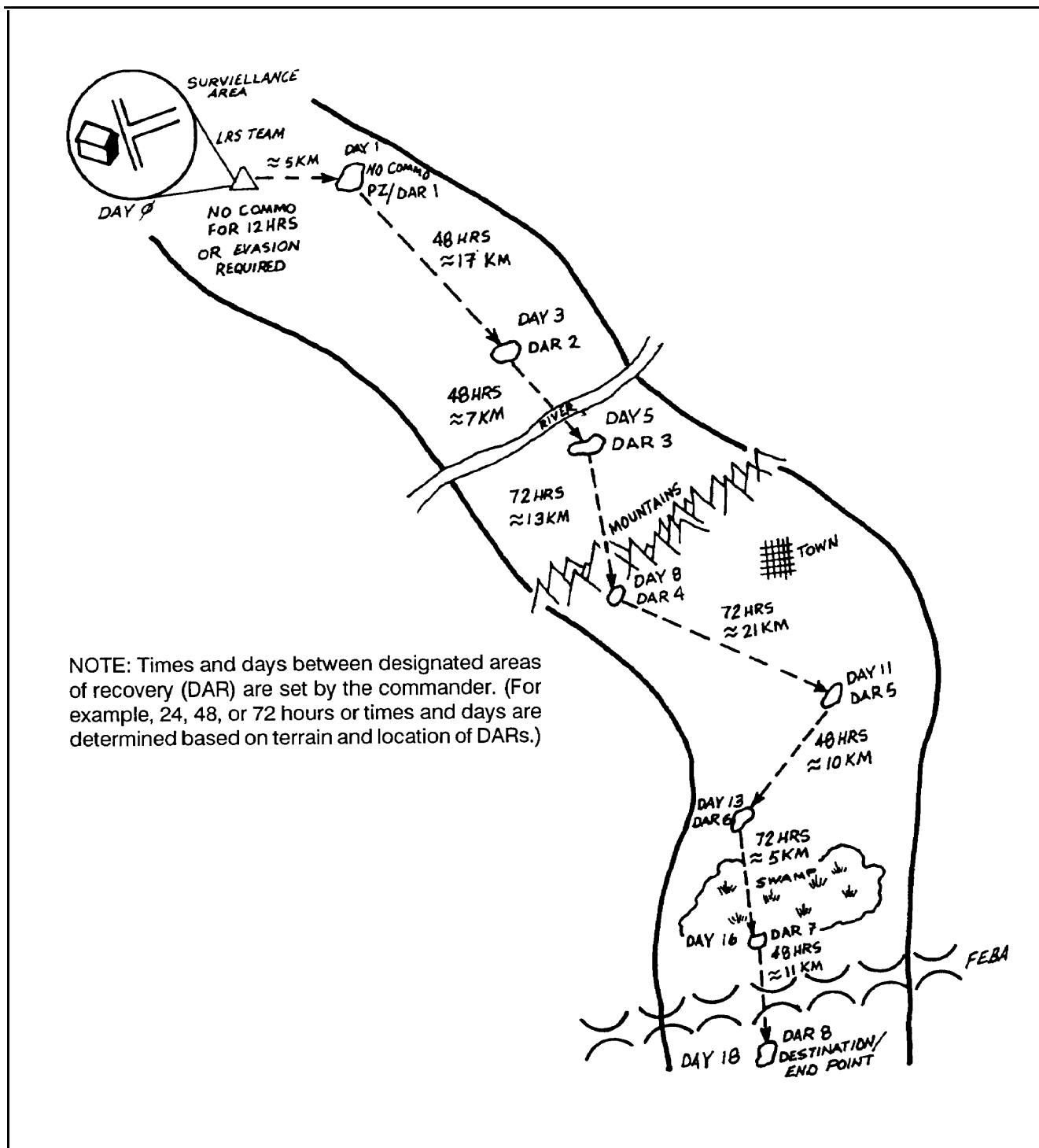

Figure F-6. Example of an evasion corridor.

TIME/EVENT	LOCATION	ACTIONS
No communication with LRSU HQ or evasion required	Target area	Attempt communication for 2 intervals (12 hours) or move to no communication PZ or DAR 1
No communication for 3 time intervals (12 hours) Day 0	Target area	Move to no communication PZ or DAR 1
No communication PZ active 0001 to 0230 hours Day 1	No communication PZ or DAR 1	Prepare PZ signal for activation
Aircraft arrives at PZ	No communication PZ or DAR 1	Activate signal
Communication equipment resupply	No communication PZ or DAR 1	Continue mission
No communication resupply	No communication PZ or DAR 1	Exfiltrate
No aircraft arrives	No communication PZ or DAR 1	Move to DAR 2
Move to DAR 2 (time interval is 48 hours) Days 1 and 2	En route, move during limited visibility	Patrol base during daylight
DAR 2 active 0100 to 0300 Day 3	DAR 2	Prepare PZ signal for activation
Aircraft arrives DAR 2	DAR 2	Exfiltrate
No aircraft arrives	DAR 2	Move to DAR 3
Move to DAR 3 (time interval is 48 hours) Days 3 and 4	En route, move during limited visibility	Patrol base during daylight
<p>NOTE: The timetable continues until the last DAR. Time and days between DARs are set by the commander and considered by the team leader when determining the location for DARs. Times and days between DARs can also be determined based on the terrain and location of the DARs. By using a timetable as described above, the LRSU commander or combat search and rescue commander knows the DAR in effect for a particular time.</p>		

**Figure F-7. Example of a timetable.**

**F-3. SURVIVAL**

LRS teams must know the principles of survival and must be proficient in survival techniques to successfully conduct evasion and escape operations. (See FMs 21-76 and 31-70 for more information on the principles and techniques of survival.)

---

a. Survival tasks that LRSU soldiers must be proficient in areas follows:

- Area study.
- The mnemonic **S-U-R-V-I-V-A-L**:  
S ize up the situation.  
U ndue haste makes waste.  
R emember where you are.  
V anquish fear and panic.  
I mprovise.  
V alue living.  
A ct like the natives.  
L ive by your wits; but for now learn the basics.
- Water procurement.
- Water purification.
- Field-expedient direction finding.
- Shelter construction.
- Fires.
- Rope making.
- Signaling.
- Smokers and meat preparation.
- Tools and weapons.
- Traps and snares.
- Fishing.
- Edible plant identification and preparation.
- Field-expedient first aid.
- Prisoners of war tap code.

b. A useful technique for organizing for survival is the 3-phase individual survival kit. The content of each phase of the kit depends on the environment in the area of operations and available supplies. This is only an example of the contents of a 3-phase survival kit.

(1) *Phase 1 (extreme)*. Soldier without any equipment (load-bearing equipment or rucksack). Items to be earned and their suggested uses include:

- (a) Safety pins in hat (fishing hooks or holding torn clothes).
- (b) Utility knife with magnesium fire starter on 550 cord wrapped around waist (knife, making ropes, fire starter).
- (c) Wrist compass (navigation).



(2) *Phase 2 (moderate)*. Soldiers with load-bearing equipment. Load-bearing equipment should contain a small survival kit. Kit should be tailored to the area of operation and should only contain basic health and survival necessities.

- (a) 550 cord, 6 feet (cordage, tiedown, fishing line, weapons, snares).
- (b) Waterproofed matches or lighter (fire starter).
- (c) Waterproofed iodine tablets (water purification, small cuts).
- (d) Fish hooks or lures (fishing).
- (e) Heavy duty knife with sharpener, bayonet type (heavy chopping or cutting).
- (f) Mirror (signaling).
- (g) Tape (utility work).
- (h) Aspirin.
- (i) Clear plastic bag (water purification, solar stills).
- (j) Candles (heat, light).
- (k) Surgical tubing (snares, weapons, drinking tube).
- (l) Tripwire (traps, snares, weapons).
- (m) Dental floss (cordage, fishing line, tiedown, traps).
- (n) Upholstery needles (sewing, fish hooks).

(3) *Phase 3 (slight)*. Soldier with load-bearing equipment and rucksack. Rucksack should only contain minimal equipment. The following are some examples:

- (a) Poncho (shelters, gather water such as dew).
- (b) Water purification pump.
- (c) Cordage (550), 20 feet.
- (d) Change of clothes.
- (e) Cold and wet weather jacket and pants.
- (f) Poncho liner or lightweight sleeping bag.

NOTE: Items chosen for survival kits should have multiple uses. The items in the above list are only suggestions.

## APPENDIX G

## INTELLIGENCE

*This appendix provides information on intelligence preparation of the battlefield; mission folders; and conducting threat vehicle identification, order of battle, and intelligence training.*

**G-1. INTELLIGENCE PREPARATION OF THE BATTLEFIELD**

IPB is the cornerstone of intelligence operations and the commander's scheme of fire and maneuver. IPB predicts the allocation and employment of collection assets. It is the basis for situation and target development. It is also the basis for target value analysis, which identifies high-value targets for fire support targeting. The IPB process provides a graphic intelligence estimate for the commander. (For more information, see FM 34-130.)

a. The all-source production section of G2 considers the needs of the division combat and support elements to provide them with IPB products. IPB is a four-step process: define the battlefield environment, describe the battlefield's effects, evaluate the threat, and determine threat courses of action.

(1) *Define the battlefield environment.* The battlefield area is the geographical area on which the commander has responsibility and authority to conduct military operations. Based on METT-T and the commander's concept of operations, the G2 recommends to the commander the boundaries of the division area of interest.

(2) *Describe the battlefield's effects.* This step determines how the battlefield environment affects threat and friendly operations. This evaluation focuses on the general capabilities of each force until courses of action are developed in later steps of the IPB process. This step always includes an examination of terrain and weather, and their affects on friendly and threat operations.

(3) *Evaluate the threat.* During this step, a determination is made of threat force capabilities and the doctrinal principles and the tactics, techniques, and procedures that threat forces prefer to employ. This evaluation is portrayed in a threat model, which includes doctrinal templates that depict how the threat operates when unconstrained by the effects of the battlefield environment.

(4) *Determine threat courses of action.* This step integrates the results of the previous steps into a meaningful conclusion. Models are developed that depict the threat's available courses of action. These models are developed given the effects of the specific battlefield environment. As a minimum, the most likely and the most dangerous threat courses of action should be depicted.

b. The commander plans deep operations based on the factors of METT-T and IPB analyses. He begins planning the interdiction of enemy forces (primary area of operations for LRSU), while they are deep in the area of interest. He identifies and plans the attack well before the situation places the enemy force at the interdiction point. He projects how enemy second-echelon forces will react to friendly activities. He selects the time and place for attacks based on intelligence gathering.

(1) The LRS company and the LRS detachment perform several critical tasks in support of their parent unit commander's concept of the operation. How well the LRS unit performs its mission may decide the success or failure of the main force. Therefore, the LRS commander and team leader must know where they fit into the intelligence collection process. The LRSU's mission helps confirm or deny the commander's IPB in the unit area of interest.

(2) From the decision support template of the IPB cycle, the S2 and S3 prepare a detailed reconnaissance and surveillance plan. The reconnaissance and surveillance plan graphically depicts where and when reconnaissance and surveillance elements (for example, LRS elements) should look for the enemy. The reconnaissance and surveillance plan must direct specific tasks and priorities to LRS teams. Once near their objective, the LRS team confirms or denies the IPB. LRS teams confirm or deny the IPB by answering SIR to the commander's PIR. Critical information the LRS elements find during either reconnaissance or surveillance operations is relayed rapidly and accurately.

## **G-2. MISSION FOLDER PREPARATION**

The mission folder is based on mission responsibility of the individual unit. It is a stand-alone document consisting of who, what, where, when, and why to fill the needs of the commander. It contains detailed information of the mission to include maps, photographs sketches, climatology, area geography, and recent enemy activity. It also contains coordination, such as insertion and extraction means and corridors, made by the division staff and LRS headquarters to aid the mission. The mission folder for training should be prepared to reflect the unit's mission. These are unit METL dependent.

a. The folder should never tell the surveillance team leader how to execute his mission, but should contain all the information he needs to plan it. G2, G3, and LRS headquarters are responsible for completion of the mission folder.

---

b. The contents of the mission folder areas follows.

(1) *Part 1—Mission identification data.*

- Target analysis.
- Composition and disposition of enemy forces.
- Radio direction finding capabilities of enemy.
- Rear area security ability and reaction time of enemy forces.

(2) *Part 2—Coordinating instructions.*

- Insertion and extraction.
  - Combat search and rescue procedures and evasion and escape corridors.
  - Link-up procedures.
    - Isolated Personnel Report, DD Form 1833.
    - Friendly.
    - Partisan.
    - Contact point.
  - Other than air.
  - Departure and reentry of forward friendly unit.
  - Fire support.
  - Resupply: Cache and air resupply.
  - Boundaries: To forward friendly unit and other assets.
  - Attachments: Topographical engineer team, fire support officer, air liaison officer, air defense artillery, joint air party, and so forth.
- Special weapons and equipment.
- Communication data.

(3) *Part 3—Required maps and imagery.*

- Area orientation maps.
  - 1:50,000 minimum for planning and operations.
  - 1:250,000 minimum for planning.
  - Joint operations graphics minimum for planning.
- Target oriented maps.
  - Detailed planning maps.
  - Line-of-sight graphics or matrix.

- From proposed surveillance sites to target.
  - From proposed target to surveillance sites.
  - Within 500 meters of each proposed false insertion site.
  - Gazetteer oriented to terrain, grid coordinate, and geographical features. (Gazetteer is a map dictionary alphabetically listing every named feature in the country.)
  - Gridded imagery of target specific.
  - Gridded imagery of target area.
- (4) *Part 4—Target area information.*
- Geographical data: Average slope, soil table, and trafficability.
  - Meteorological data.
    - Effects of light and illumination on friendly forces, and enemy forces and their use of night observation devices.
    - Weather: Current and historical.
    - Effects of weather on friendly forces and enemy forces.
  - Hydrographic data.
    - Tidal and current.
    - Drainage.
    - Flooding.
  - Cultural features.
    - Language.
    - Religion: Tolerance and dominance.
    - Mores.
    - Values.
    - US support by indigenous personnel.
  - Infiltration and exfiltration planning factors.
    - Routes.
    - Security.
    - Medical.
    - Assets available.
    - Unit qualifications.

- Survival, evasion, resistance, and escape planning factors.
    - Isolated Personnel Report, DD Form 1833.
    - Area studies.
    - Culture: Religion and morals.
    - Blood chits.
    - Food sources.
      - Animals (poisonous, inedible).
      - Plants (poisonous, nonpoisonous).
      - Water—potable.
    - Endemic diseases.
    - Currency.
- (5) *Part 5—Target area activity.* Recent activity.
- Train-up or refit.
  - Movement to combat.
  - Rehearsals.
- (6) *Part 6—References.* Prior area intelligence.
- Unconventional warfare forces.
  - Pre-employed LRS teams.
  - Line crossers.
  - Refugees.

c. An intelligence estimate and an intelligence annex are also useful to the team in planning their mission.

(1) *Intelligence estimate.* An intelligence estimate is a five-paragraph document containing the latest intelligence of the battlefield and enemy capabilities and limitations. It also contains any notable conclusions about the total effects of the area of operations on friendly and probable enemy courses of action, and the effects of enemy exploitable vulnerabilities.

(2) *Intelligence annex.* An intelligence annex is a formal but brief eight-paragraph tasking document containing necessary intelligence orders or guidance for the operation. It gives subordinate commanders instructions on specific collection and reporting requirements, PIR and IR, and associated SIR. It may accompany the operation plan or OPORD.

### **G-3. INTELLIGENCE TRAINING**

Specific training on vehicle identification, order of battle, and intelligence is critical to successful mission accomplishment for both the LRS headquarters

personnel and team members. Training priorities are established in accordance with the unit METL.

a. The team leader prioritizes the most urgent training needs.

(1) Train teams for compatibility with G2.

(a) Develop briefing and debriefing skills.

(b) Aid in credibility of team reporting ability.

(c) Identify gaps between teams availability and capability and G2 taskings.

(d) Make available G2 assets to LRS units.

(2) Train teams on vehicle identification and table of organization and equipment key signature vehicles and equipment.

(3) Train teams on preparing for debriefing.

(4) Train teams on use and recognition of PIR, IR, SIR and how they are produced and used by G2.

(5) Train teams on making area studies—historical, sociological, economic, religious, medical, political, cultural, languages, geological, military (especially influences, for example, US, United Kingdom, Chinese, and any other country that provides equipment and training).

(6) Train teams on the order of battle-enemy warfighting doctrine and the integration of outside military influences on enemy doctrine, philosophies, and ideology. Additionally, key vehicles and equipment placement in organizations and formations.

(7) Train teams on the team's real-world mission when developing IPB. Planning for operations other than war is often overlooked and poorly trained, teams should evaluate and restructure to prepare for this contingency. IPB in operations other than war is slow to develop and has the potential to change rapidly. Preparation and use of mission folders for potential targets are essential.

(8) Train teams on the doctrine of enemy—

- Offensive operations—major influences.
- Defensive operations—major influences.
- Rear area security.
- IPB—doctrine, history.

b. The team leader plans the intelligence training schedule.

(1) For active duty soldiers, the recommended intelligence training is—

- One hour per day per week training on vehicle identification.

- Thirty hours per month training on forces and equipment specific to units in real-world contingency areas; for example, Mideast and South America.
  - Field training exercises or deployments should incorporate intelligence training by vehicle photo packets, as a minimum.
- (2) For Reserve Components and National Guard units, the recommended intelligence training schedule is as follows:
- (a) *Weekend drill.*
- Five hours of intelligence training.  
Three hours of vehicle identification.  
Priority: Area of operation; former Soviet; former Soviet alliance; and Third World, nonaligned.
  - Two hours of order of battle. Priority: Unit organization; offensive, defensive, and rear area operations; and IPB—doctrine, history.
- (b) *Annual training.*
- Fifteen hours of intelligence training: Briefing and debriefing and imagery interpretation by imagery interpreters (96D).
  - Twelve hours of vehicle identification, priority as above.
  - Three hours of order of battle, priority as above.

#### **G-4. INTELLIGENCE RESOURCES**

The LRS element is a direct asset of the corps and division commander through the G2 with a vast amount of resources available to them. The assets are as follows.

- a. G2.
- (1) Air liaison for Air Force.
  - (2) Staff weather officer: Light and weather data and historical weather data.
  - (3) Security: OPSEC and counterintelligence.
  - (4) Intelligence updates on the unit's contingency area.
  - (5) G2 and LRS interface.
  - (6) Liaison officer training for (at a minimum):
    - Commander and executive officer.



- Operations sergeant.
  - Intelligence sergeant and analyst.
  - Team leader.
- (7) Topographical data:
- Line-of-sight graphics.
  - Defense mapping agency.
  - Obstacle overlays.
  - Terrain analysis.
- (8) Imagery support: Interpretation and training by imagery interpreters (96D).
- (9) Integrated training with other intelligence-gathering assets to develop a greater understanding of the intelligence battlefield operating systems.
- (10) Planning procedures: Intelligence updates and current changes.
- b. Additional Resource Assets.**
- (1) Computers (integrated video disc, point of contact is Company D, LRS Leader's Course, 4th Ranger Training Brigade, Fort Benning, Georgia 31905).
- (2) Manuals.
- (3) Janes publications and similar products.
- (4) Vehicle and order of battle slides and photographs (G2).
- (5) PCQT (computer floppy disc; point of contact is US Army Foreign Science and Technology Center, Fort Meade, Maryland).
- (6) Video or movie footage.
- (7) Visualization:
- Overhead projector.
  - Intelligence School, Fort Huachuca, Arizona.
  - Foreign Science and Technology Center, Fort Meade, Maryland.
- (8) Quizzes:
- Flashcards.
  - Slides or photographs.
  - List of features for vehicle identification.
- (9) Posttesting to determine the effectiveness of overall training.
- (10) Models—1: 100 scale models available with use of spotter scopes from 50 to 75 meters is hands-on training that is expeditious and excellent for detection

---

and identification training. (Military Training Equipment, 357 UXbridge Road, Rickmansworth, Hertfordshire, WD3 2DT, United Kingdom.

c. **Military Resources.**

- Directorate of Threat and Security  
US Army Infantry Center  
Fort Benning, Georgia 31905-5000  
(706] 545-1561 DSN: 835-1561
- Long-Range Surveillance Leaders Course  
Fort Benning, Georgia 31905  
DSN: 784-6831/6212
- Advanced Imagery Interpretation Course  
Scherstien Compound Germany 497 RTG/INIOET  
APO New York, New York 09633 Student handout  
is a catalog of key vehicles and equipment with table  
of organization and equipment breakdown.
- NATO Identification Course  
RAF Alcanbury, UK, England  
Student handout for  
vehicle identification.
- Foreign Materials Handling and Exploitation  
201st MI Battalion, Fort Meade, Maryland  
Course available through Red Train;  
see Red Train catalog.
- US Army Intelligence Center and School  
Non-Warsaw Pact and Third World  
Countries correspondence courses:  
Commander, US Army Ordnance  
Center and School, ATTN: ATSC-TD-RCO  
Aberdeen Proving Ground, Maryland 21005
- Red Thrust Star, c/o S2, 177th Armored Bde  
Fort Irwin, California 92310-5031  
DSN: 470-5239/5207
- Department of the Army, US Army, Element,  
International LRRP School, APO New York 09035  
Bundespost 0751-44033 Ext 168  
Bundespost 0751-51817

**d. Civilian Resources.**

- Janes Defense Weekly Circulation Manager  
1340 Braddock Place, Suite 300 PO Box 1436  
Alexandria, Virginia 22313-2036  
(703) 683-3700 FAX (703) 836-0029
- Janes Yearbook (Vehicle Identification)  
4th Floor 115 5th Avenue  
New York, New York 10003  
(212) 254-9097 TLX 272562
- International Defense Review  
c/o Publications Expediting, Inc.  
200 Meacham Avenue  
Elmont, New York 11003 (516) 352-7300
- Military Training Equipment  
(lead and rubber model 1:100 scale)  
USA Representative: Fairey Engineering  
526 King Street, Suite 201  
Alexandria, Virginia 22314 (703) 543-3397
- Local library.

## APPENDIX H

**ORDERS**

*This appendix is an aid for LRS units to issue warning orders, operation orders, and fragmentary orders.*

**H-1. WARNING ORDER FORMAT**

The warning order has no specific format. One technique is to use the five-paragraph OPORD format. The leader should consider the following when preparing a warning order. (Figure H-1, page H-2.)

- Movement time to planning site.
- Strength figures (provided to executive officer and first sergeant for movement and Class I planning).
- Time of personnel and equipment attachments (communications, transportation, and aidman).
- Commander's warning order.
- Commander's operations briefing or order.
- Issue and turn-in of classified material.
- Communications coordination.
- Team warning or operation order.
- Isolated personnel report (DD Form 1833).
- Air mission briefing and coordination.
- Team briefbacks to operations.
- Commander's briefback to higher headquarters.
- Issue of equipment.
- Communication exercise times.
- Test firing and zeroing equipment (including night observation devices).
- Vehicle inspection and dispatch.
- Rehearsals (day or night, with or without equipment).
- Distribution of ammunition.
- Initial or final inspections.
- Security requirements.

- Religious services.
- Commander or higher final pre-mission talk to soldiers.
- Final inspection of soldiers.
- Security sweep by operations.
- Load times.
- Take-off time.
- Time on target.

**1. SITUATION.**

Brief statement of enemy and friendly situation; attachments and detachments to the team.

**2. MISSION.**

Who, what, when, where, why, and expected duration of mission.

**3. EXECUTION.**

- a. Tentative concept of the operation (optional).
- b. Time schedule.
- c. Tasks to team members.
- d. Uniform and equipment changes (from the SOP) that apply to all.
- e. Special weapons, ammunition, or items of equipment (other than those in the SOP) such as suppressors, optics, or night vision devices.

**4. SERVICE SUPPORT.**

CSS tasks to be accomplished that are different from the SOP.

**Figure H-1. Example warning order format.**

**H-2. OPERATION ORDER FORMAT**

An OPORD is a directive issued by the unit leader to his subordinate leaders or individuals. The purpose of the OPORD is to effect the coordinated execution of a specific operation. (Figure H-2.)

**TASK ORGANIZATION:** Explains how the unit is organized for the operation. If there is no change to previous task organization, the leader indicates “no change.”

**1. SITUATION.**

**a. Enemy Forces.**

- (1) Disposition, composition, strength, and identification.
- (2) Capabilities.
- (3) Most probable course of action.
- (4) Civilian population.
  - (a) Culture.
  - (b) Political.
  - (c) Home guard.
  - (d) Restrictions and curfews.

**b. Friendly Forces.**

- (1) Mission of next higher unit.
- (2) Concept of the operation for the next higher unit.
- (3) Locations and planned actions of units on left, right, front, and rear, and supporting or reinforcing.
- (4) Missions and routes of adjacent patrols.
- (5) Terrain (how it will affect the team and the enemy).
- (6) Light and weather (how it will affect the team and the enemy).

**c. Attachments and Detachments.**

**2. MISSION.**

Who, what, when, where, why, and expected duration of mission. A clear and concise statement of the task and purpose. The team leader derives the restated mission from his mission analysis.

**3. EXECUTION.**

Gives the stated vision that defines the purpose of the operations and the relationship among the force, the enemy, and the terrain.

**Figure H-2. Example operation order format.**

**a. Concept of the operation.**

Explains, in general terms, how the team will accomplish the mission. Identifies the mission essential and other essential tasks. Describes the commander's intent.

- (1) Maneuver.
- (2) Fires. Gives the team the target numbers and shows the team the numbers on the overlay. Explains how and when the team will use fires.
- (3) Intelligence.
- (4) Electronic warfare.
- (5) Engineering.
- (6) Other.

**b. Tasks to Maneuver Units.**

Specifies all tasks. If implied, the leader consults with higher headquarters if time permits.

- (1) Teams and sections.
- (2) Special teams and key individuals.

**c. Tasks to Combat Support Units.****d. Coordinating Instructions.**

- (1) Actions at the objective.
- (2) Timing paragraph. Explains the time sequencing from after the OPORD to actions at the objective.
- (3) Priority intelligence requirements and associated specific information requirements.
- (4) Information requirements and associated specific information requirements.
- (5) Movement techniques.
- (6) Primary route.
- (7) Alternate route.
- (8) Departure and re-entry of friendly positions.
  - (a) Departure point.
  - (b) Re-entry point.

**Figure H-2. Example operation order format (continued).**

- (9) Rally points and actions at rally points
- (10) Actions on enemy contact.
- (11) Actions at danger areas.
- (12) Actions at halts.
- (13) Debriefing (time and place).
- (14) MOPP level.
- (15) Rehearsals.
- (16) Inspections.
- (17) Minimum equipment and personnel to complete mission.
- (18) Soldier safety and operational exposure guide.
- (19) Rules of engagement.
- (20) Annexes (air assault, airborne, stream crossing, truck, linkup, evasion and escape, hide site, cache, and so forth).

#### **4. SERVICE SUPPORT.**

##### **a. General.**

##### **b. Materials and services.**

- (1) Supply.
  - (a) Rations.
  - (b) Weapons and ammunition.
  - (c) Uniform and equipment.
- (2) Transportation.
- (3) Services.
  - (a) Method of handling dead.
  - (b) Field services.
  - (c) Health services.
- (4) Maintenance.
- (5) Medical evacuation and hospitalization

##### **c. Personnel.**

(Friendly and enemy prisoners of war.)

##### **d. Miscellaneous.**

**Figure H-2. Example operation order format (continued).**



**5. COMMAND AND SIGNAL.**

**a. Command.**

- (1) Location of commander, executive officer, first sergeant, detachment commander, team leader, assistant team leader, section leader, as applicable, during movement and on the objective.
- (2) Succession of command (per company SOP, or other as needed).

**b. Signal.**

- (1) Time zone used.
- (2) SOI and matrix used.
- (3) Pyrotechnics and signals (as alternate means of control, review team SOPs for arm-and-hand and light signals).
- (4) Challenge and password.
  - (a) Regular.
  - (b) Forward of friendly lines.
  - (c) Running.
- (5) Code words and reports (see communications annex).

**Annexes:**

- A— Air Assault and Airborne
- B— Stream Crossing
- C— Vehicle Movement
- D— Evasion and Escape
- E— Linkup
- F— Rest Overnight, Hide Site, Surveillance Site
- G— Cache Site

**ANNEX A (AIR ASSAULT AND AIRBORNE) to OPORD**

**1. SITUATION.**

**a. Enemy.**

- (1) Disposition, composition, strength, and identification (air defense).
- (2) Weather (how it will affect the air operation).
- (3) Terrain (how it will affect the air operation).

**Figure H-2. Example operation order format (continued).**

- b. Friendly** (includes units supporting operation, that is, helicopters, artillery, air defense, electronic countermeasures, USAF).

## **2. MISSION.**

Only pertaining to the air operation.

## **3. EXECUTION.**

Commander's intent.

### **a. Concept of the Operation.**

- (1) Maneuver.
- (2) Fires.
- (3) Intelligence.
- (4) Electronic warfare.
- (5) Other.

### **b. Tasks to Maneuver Units.**

### **c. Tasks to Combat Support Units.**

### **d. Coordinating Instructions.**

- (1) Time aircraft available and location of pickup site.
- (2) Organization for movement.
- (3) Time and location for rehearsals, jump refresher, and jump master prejump inspection.
- (4) Time over forward line of own troops.
- (5) Landing zone, drop zone, and pickup zone.
  - (a) Grid.
    1. Primary.
    2. Alternate.
  - (b) Marking.
    1. Long-range (terrain feature, radio, mirror, flare).
    2. Short-range (terrain feature, radio, man-made feature, VS-17 panels, smoke, light, infrared strobe, chemical light.)

**Figure H-2. Example operation order format (continued).**

- (6) Flight route to LZ or DZ from PZ.
  - (a) General.
  - (b) Checkpoints.
  - (c) Prelanding and prejump warning.
- (7) Formations
  - (a) At pickup site.
  - (b) En route.
  - (c) At LZ, DZ, and PZ.
- (8) Actions on enemy contact and downed aircraft.
  - (a) En route.
  - (b) At LZ, DZ, and PZ.
- (9) Assembly area (grid, terrain feature, marking, assembly technique).
- (10) Method for destruction and cache of special equipment.
- (11) Rehearsals.

**4. SERVICE SUPPORT.**

- a. **Special equipment needed at LZ, DZ, and PZ.**
- b. **Special equipment needed for airborne operations.**

**5. COMMAND AND SIGNAL**

**a. Command.**

- (1) Location of team leader, assistant team leader, and RATELO in the air and at LZ or PZ.
- (2) Location of the jumpmaster, rappel master, SPIES master, FRIES master, and safeties in the aircraft.
- (3) Location of controlling personnel (platoon leader and platoon sergeant).

**b. Signal.**

**ANNEX B (STREAM CROSSING) to OPORD**

**1. SITUATION.**

**a. Enemy Forces.**

- (1) Disposition, composition, strength, and identification.

**Figure H-2. Example operation order format (continued).**

- (2) Weather (how it will affect the stream).
- (3) Terrain (how it will affect the stream).
  - (a) River width.
  - (b) River depth.
  - (c) Current.
  - (d) Vegetation.
  - (e) Obstacles.

**b. Friendly Forces.**

**2. MISSION.**

Only pertaining to the stream crossing operation.

**3. EXECUTION.**

Commander's intent.

**a. Concept of the Operation.**

- (1) Maneuver.
- (2) Fires.
- (3) Intelligence.
- (4) Engineers.
- (5) Other.

**b. Tasks to Maneuver Units.**

- (1) Elements.
- (2) Individuals.

**c. Tasks to Combat Support Units.**

**d. Coordinating Instructions.**

- (1) Crossing procedure.
- (2) Security.
- (3) Order of crossing.
- (4) Actions on enemy contact.
- (5) Alternate plan.
- (6) Rally points.
- (7) Rehearsal plan.

**Figure H-2. Example operation order format (continued).**

**4. SERVICE SUPPORT.**

Optional.

**5. COMMAND AND SIGNAL**

**a. Command.**

Location of team leader, assistant team leader, and RATELO.

**b. Signal.**

Optional.

**ANNEX C (VEHICLE MOVEMENT) to OPORD**

**1. SITUATION.**

**a. Enemy Forces.**

- (1) Disposition, composition, strength, and identification.
- (2) Weather.
- (3) Terrain (along and adjacent to route).
- (4) Vegetation.
- (5) Obstacles and potential ambush sites.

**b. Friendly Forces.**

- (1) Units along route.
- (2) Unit providing transportation.

**2. MISSION.**

Only pertaining to the vehicle movement operation.

**3. EXECUTION.**

Commander's intent.

**a. Concept of the Operation.**

- (1) Maneuver.
- (2) Fires.
- (3) Intelligence.
- (4) Electronic warfare.
- (5) Engineering.
- (6) Route.
- (7) Other.

**Figure H-2. Example operation order format (continued).**

**b. Tasks to Maneuver Units.**

- (1) Teams.
- (2) Elements.
- (3) Individuals. (Brief vehicle drivers on the routes, actions on enemy contact, and vehicle interval and speed.)

**c. Tasks to Combat Support Units.****d. Coordinating Instructions.**

- (1) Time of departure or return.
- (2) Loading and order of movement.
- (3) Actions on enemy contact.
- (4) Actions at the dismount point.
- (5) Rehearsals.
- (6) Inspections. (Inspect vehicles for the following: Serviceability [DA Form 2404]; fuel; truck—canvas and bows off, troop seats up, safety strap on; air guards up; sandbags on floor; physical condition of driver; serviceability and location of fire extinguishers.)

**4. SERVICE SUPPORT.**

Special equipment needed, sandbags, and so forth.

**5. COMMAND AND SIGNAL.****a. Command.**

Location of team leader, assistant team leader, and RATELO.

**b. Signal.**

- (1) Special signals for the movement only.
- (2) Communications in and between vehicle.

**ANNEX D (EVASION AND ESCAPE) to OPORD****1. SITUATION.****a. Enemy Forces.**

- (1) Disposition, composition, strength, and identification.
- (2) Weather.

**Figure H-2. Example operation order format (continued).**

- (3) Terrain (along evasion route, should be broken into sections).
- (4) Vegetation (along route).
- (5) Obstacles (along route, rivers, mountains, built-up areas).
- (6) Identification of other potential enemy pursuers.

**b. Friendly Forces.**

- (1) Potential units providing exfiltration.
- (2) Potential partisans providing exfiltration.
- (3) Survival features.

**2. MISSION.**

Only pertaining to the evasion and escape operation.

**3. EXECUTION.**

Commander's intent.

**a. Concept of the Operation.**

- (1) Corridor. (Provided by operations.)
- (2) Designated area of recovery locations. (Picked by team leader.)

**b. Coordinating Instructions.**

- (1) Primary route in corridor.
- (2) Alternate route in corridor.
- (3) Security.
- (4) Actions at designated areas of recovery.
- (5) Time designated area of recovery is active and closed.
- (6) Time interval and distance between designated areas of recovery.
- (7) How and when the team will rally if separated.
- (8) Where and when isolated personnel report will be completed and reviewed.

**4. SERVICE SUPPORT.**

Any special equipment needed for survival.

**Figure H-2. Example operation order format (continued).**

**5. COMMAND AND SIGNAL.****a. Command.**

Location of team leader, assistant team leader, and RATELO at designated areas of recovery.

**b. Signal.**

Special signals for evasion and escape only, isolated personnel report, partisan.

**ANNEX E (LINKUP) to OPORD****1. SITUATION.****a. Enemy Forces.**

- (1) Disposition, composition, strength, and identification.
- (2) Terrain (at linkup site).
- (3) Vegetation (at linkup site).
- (4) Obstacles (near or at linkup site).

**b. Friendly Forces.**

- (1) Linkup unit.
- (2) DESIGNATED liaison team.

**2. MISSION.**

Only as pertaining to linkup operations.

**3. EXECUTION.**

Commander's intent.

**a. Concept of the Operation.**

- (1) Maneuver.
- (2) Fires.
- (3) Intelligence.
- (4) Electronic warfare.
- (5) Engineers.
- (6) Others.

**Figure H-2. Example operation order format (continued).**



**b. Tasks to Maneuver Units.**

- (1) Elements (hide sites, reconnaissance and security).
- (2) Individuals (security).

**c. Tasks to Combat Support Units.**

**d. Coordinating Instructions.**

- (1) Time of linkup.
- (2) Location of linkup site.
- (3) Rally points.
- (4) Actions on enemy contact.
- (5) Actions at the linkup site.
- (6) Rehearsals.

**4. SERVICE SUPPORT.**

Optional.

**5. COMMAND AND SIGNAL.**

**a. Command.**

- (1) Location of team leader, assistant team leader, and RATELO at linkup site.
- (2) Location of DESIGNATED liaison team.

**b. Signal.**

- (1) Frequencies and call signs.
- (2) Long-range recognition signal and identification.
  - (a) Day.
  - (b) Night.
- (3) Short-range recognition signal and identification.
  - (a) Day.
  - (b) Night.
- (4) Posting authentication (oral).

**Figure H-2. Example operation order format (continued).**

**ANNEX F (REST OVERNIGHT, HIDE SITE,  
SURVEILLANCE SITE) to OPORD**

**1. SITUATION.**

**a. Enemy Forces.**

- (1) Disposition, composition, strength, and identification.
- (2) Terrain (at site).
- (3) Vegetation (at site).
- (4) Obstacles (near or at site)
- (5) Soil (at site).

**b. Friendly Forces.**

**2. MISSION.**

Only as pertains to rest overnight, hide site, or surveillance site.

**3. EXECUTION.**

Commander's intent.

**a. Concept of the Operation.**

- (1) Maneuver.
- (2) Fires.
- (3) Intelligence.
- (4) Electronic warfare.
- (5) Engineers.
- (6) Other.

**b. Tasks to Maneuver Units.**

- (1) Elements.
- (2) Individuals.

**c. Tasks to Combat Support Units.**

**d. Coordinating Instructions.**

- (1) Occupation plan.
- (2) Operation plan.
- (3) Security plan.
- (4) Alert plan.

**Figure H-2. Example operation order format (continued).**

- (5) Priority of work.
- (6) Evacuation plan.
- (7) Alternate site.

**4. SERVICE SUPPORT.**

- a. **Water plan.**
- b. **Mess plan.**
- c. **Hygiene plan.**
- d. **Maintenance plan.**
- e. **Rest plan.**

**5. COMMAND AND SIGNAL.**

**a. Command.**

Location of team leader, assistant team leader, and RATELO at site.

**b. Signal.**

- (1) Location of communications site.
- (2) Antennas used.

**ANNEX G (CACHE SITE) to OPORD**

**1. SITUATION.**

**a. Enemy Forces.**

- (1) Disposition, composition, strength, and identification.
- (2) Terrain (at cache site).
- (3) Vegetation (at cache site).
- (4) Obstacles (near or at cache site).
- (5) Soil (at cache site).

**b. Friendly Forces.**

**2. MISSION.**

Only as pertains to cache site.

**Figure H-2. Example operation order format (continued).**

**3. EXECUTION.**

Commander's intent.

**a. Concept of the Operation.**

- (1) Maneuver.
- (2) Fires.
- (3) Intelligence.
- (4) Other.

**b. Tasks to Maneuver Units.**

- (1) Elements (security, digging).
- (2) Individuals (report recorder).

**c. Tasks to Combat Support Units.****d. Coordinating Instructions.**

- (1) Security plan.
- (2) Recording plan.
- (3) Site preparation plan.
- (4) Site digging plan.
- (5) Spoil disposal plan.
- (6) Actions on enemy contact.
- (7) Rehearsals.

**4. SERVICE SUPPORT.**

- a. Recording material.**
- b. Digging material.**
- c. Spoil container.**
- d. Cache container.**

**5. COMMAND AND SIGNAL.****a. Command.**

Location of team leader, assistant team leader, and RATELO at cache site.

**Figure H-2. Example operation order format (continued).**

**b. Signal.**

Twelve-point cache report.

- (1) *Type of cache.* The element for which the cache is for (guerrilla unit, sabotage cell, operator) and the type of the cached material (weapons, demolitions, communications).
- (2) *Method of caching.* Burial, concealment, or submersion.
- (3) *Contents.* An itemized list of all materials in each container with a description of how each item is packaged.
- (4) *Description of containers.* The size, weight, and other descriptive details. If several containers are included in the cache, each container should be numbered. Each container can be referenced by its number on the sketch of the cache.
- (5) *General area.* The easily recognizable names of places, which include the country, province, and smaller political divisions, down to the nearest town or village.
- (6) *Immediate area.* The immediate reference point and instructions for proceeding from the point to the final reference point. All landmarks that aid visual recognition of the route should be described.
- (7) *Cache location.* The final reference point and the exact sightings, linear measurements, for pinpointing the cache. All measurements must be stated in the linear units (meters, feet) that the recovery agent can understand and use.
- (8) *Emplacement details.* All features of the site or natural conditions that must be considered for retrieving the cache. The following represent the essentials, depending on the method of caching.
  - (a) *Burial.* Exact depth underground of each container. Precise description of shoring (if used). All seasonal variations (surface vegetation, date and depth of ground freezing and thawing). The type of soil and the time required for emplacement also provide useful guides for planning the recovery operation.

**Figure H-2. Example operation order format (continued).**

- (b) **Concealment.** Exactly how the cache is placed in the site and any covering (plaster, bricks) that must be penetrated or removed to recover the cache. Full instructions should be provided if removing or replacing the covering involves any special problems or techniques (matching the plaster or mortar). All necessary information about a custodian, if one is used, should be included.
- (c) **Submersion.** Depth of the water (including high- and low-water marks); submersion depth (if the container does not rest on the bottom of the water); type of bottom; water motion; clearness of the water; usual freezing and thawing dates.
- (9) *Operational data and remarks.* List of equipment needed for recovery of the cache. Special consideration should be given to any equipment that may be needed for recovery, even though it was not used in emplacement. Description of at least two routes to the site that offer maximum natural concealment and means of escape in case of sudden attack. Location of nearby houses and thoroughfares. Description of local security forces, their regular posts and patrol routes near the cache. Suggestions for cover when visiting the site, including warning of what cover to avoid; any other information that may aid planning the recovery operation.
- (10) *Dates of emplacement and duration of the cache.* This is based on an estimate of how long the contents of the cache will remain usable. Pertinent factors include: the normal shelf life of items that deteriorate with time (medicine, batteries); the expiration date of official documents/licenses); how long the packaging will withstand moisture penetration or corrosion.
- (11) *Sketches and diagrams.* Whatever sketches and diagrams are necessary to illustrate the instructions for locating the cache and the description of the cache. These should include at least an area sketch, showing the route from the immediate reference point to the final reference point (see sketch A, page H-20), and a site diagram showing precisely how the cache is pinpointed (see sketch B, page H-20). Photographs of the immediate area, the immediate reference point, final reference point, and other landmarks near the site are not essential, but they may be helpful.

**Figure H-2. Example operation order format (continued).**

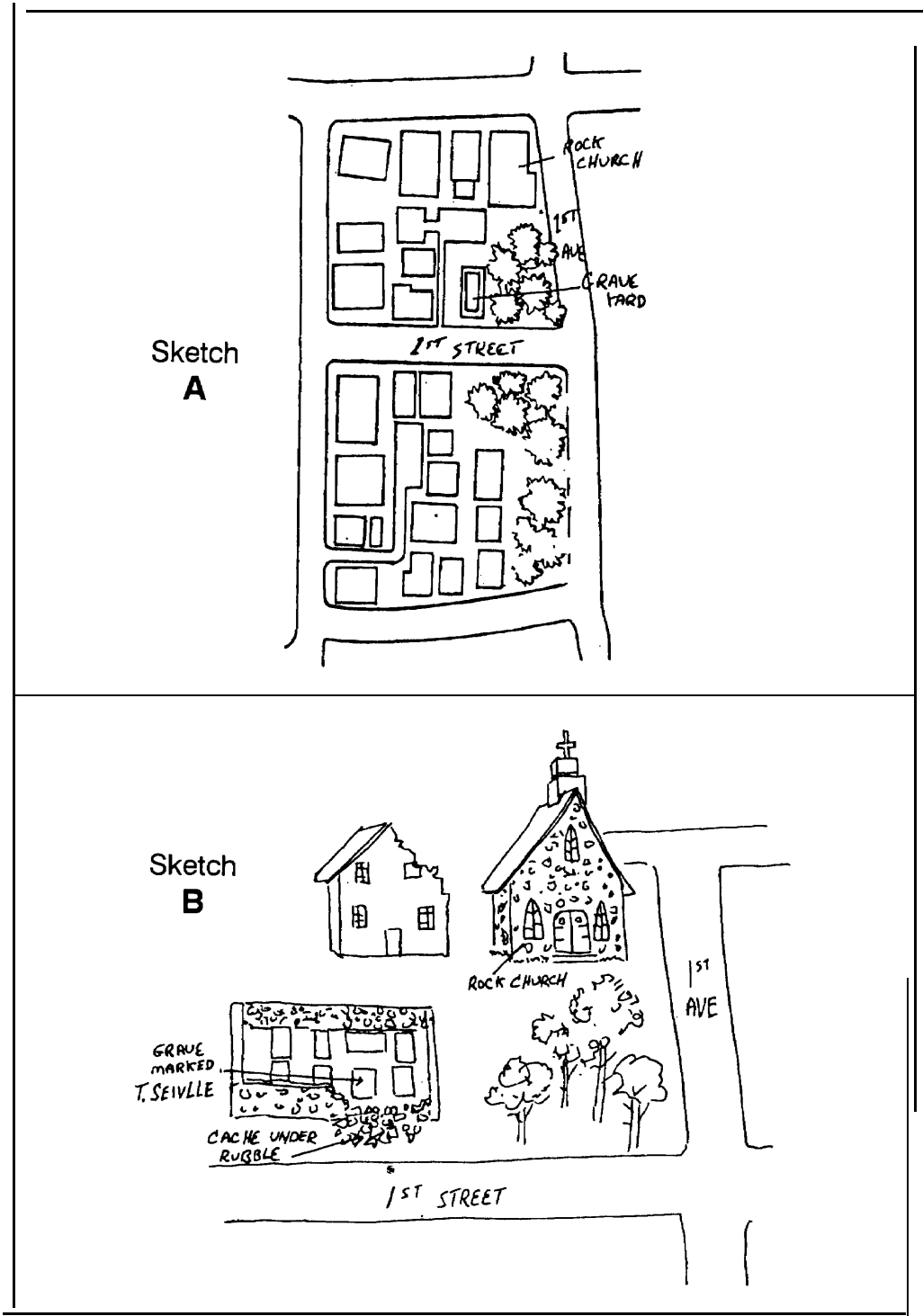

Figure H-2. Example operation order format (continued).

- (12) *Radio message for recovery.* A message should be drafted in case an emergency. The best time for drafting the message is when the details are fresh in the mind of the emplacer. The radio message should include type of cache, method of caching, and concise instructions for locating the site. These instructions must be clear and be brief enough for secure radio transmission. The preparer considers the intended recovery agent's familiarity with the area as well as the maps and makeshift surveying instruments that will be available to him. The message must be in a language he is sure to understand; it must be drafted or translated by someone who is fluent in the language. The following example radio message gives instructions for recovering the cache shown in sample sketches **A** and **B**. This sample message illustrates the minimum data that is needed for recovery. Additional data should be included in a radio message only when special circumstances require it. For instance, if a cached package is too heavy or too large for one person to carry, the weight or the exterior dimensions should be included. The depth of a submerged cache ordinarily should be specified, but the depth of a buried cache should not be included unless it is buried deeper than the usual 45 centimeters.

#### EXAMPLE RADIO MESSAGE

Communication cache in three holes in "Y" Province, "X" Country in graveyard three kilometers east of city "A" on north side of Route Five. Cache is in northeast corner near walled plot. Container One is west of the plot one two meters from northwest corner and one six meters from southwest corner. Container two is four meters west of southwest corner in line with south side. Container three is on south side adjacent to southeast corner of plot.

**NOTE:** Success of the caching operation may depend on attention to details that may seem minor to a nonprofessional. Security factors such as the cover of the caching party, the sterility of the material cached, and the obliteration of the slightest trace of the operation are vital. Important, too, are the technical factors that govern the preservation of the material in usable condition and the recording of data essential for recovery. Successful caching entails adhering to the basic principles of clandestine operations as well as knowing the technicalities of the operation. These high standards of security and "know-how" must be instilled through meticulous training.

**Figure H-2. Example operation order format (continued).**



**H-3. FRAGMENTARY ORDER FORMAT**

The FRAGO is an abbreviated version of the OPORD. The leader uses it when the planning process has been shortened. The FRAGO follows the standard five paragraph OPORD format. Leaders may omit unneeded items. (Figure H-3.)

<p><b>TASK ORGANIZATION</b> (if changed)</p> <p><b>1. SITUATION.</b></p> <ul style="list-style-type: none"><li>a. Enemy Forces.</li><li>b. Friendly Forces.</li></ul> <p><b>2. MISSION.</b></p> <p><b>3. EXECUTION.</b></p> <ul style="list-style-type: none"><li>a. Commander's intent.</li><li>b. Maneuver.</li><li>c. Fires.</li><li>d. Intelligence and electronic warfare.</li><li>e. Individual tasks.</li><li>f. Coordinating instructions.</li></ul> <p><b>4. SERVICE SUPPORT.</b></p> <p>If changed.</p> <p><b>5. COMMAND AND SIGNAL.</b></p> <p>If changed.</p>
---

**Figure H-3. Example fragmentary order format.**

## APPENDIX I

**BRIEFBACK AND DEBRIEFING FORMATS**

*The briefpack and debrief convey information about the impending mission and the completed mission, respectively. The briefback is a formal or an informal presentation normally given to the commander and any guests who may be invited. The amount of information presented is usually established by SOP. The debrief draws information from the team, and it is usually conducted immediately following the mission. The debriefing is conducted by the commander or his representative or by someone representing the G2.*

**I-1. BRIEFBACK FORMAT**

The following is an example of a briefback format.

**EXAMPLE**1. TEAM LEADER: “Good (**morning**), sir.”a. **Introduction of the team personnel.**

“Sir, I am (**rank, name**), the team leader for Team \_\_\_\_\_, \_\_\_\_\_ Platoon, \_\_\_\_\_ Company. The other members of the team are—

(**rank, name**), assistant team leader.

(**rank, name**), senior observer.

(**rank, name**), radiotelephone operator.

(**rank, name**), observer.

(**rank, name**), observer.

b. **Location and description of briefing aids.**

“Sir, in front of the mission packet is a briefback format, and our team SOPs. Please hold questions until the end of the briefback.”

c. **Mission statement.**

“Sir, the mission of Team \_\_\_\_\_ is: (**from operation order**). (He uses the chart to show objective, grid, coordinate, from, and to.)

END BRIEF OF TEAM LEADER: “Sir, I will be followed by (**rank, name**) observer.”

2. OBSERVER: “Good (**morning**), sir.”a. **Terrain.**

(1) “Sir, I will point out the terrain considerations on the map.”

(2) "Obstacles in our area of operations that interfere with dismounted movement are \_\_\_\_\_."

(3) "Obstacles that interfere with mounted movement are \_\_\_\_\_."

(4) "Avenues of approach in our area that help mounted movement are \_\_\_\_\_."

**b. Key terrain.**

"Sir, the following areas are not occupied by enemy forces; however, if occupied, this key terrain would cause the team to change its plan. \_\_\_\_\_."

**c. Observation and fields of fire.**

(1) "Sir, the team will have to avoid the following areas: \_\_\_\_\_."

(2) "The team will have to cross these danger areas: \_\_\_\_\_."

(3) "There are \_\_\_ potential observation points around the objective: \_\_\_\_\_."

**d. Cover and concealment.**

"These points provide the team with the best cover and concealment of all possible observation points around the objective: ."

**e. Weather and light data.**

(1) "Sir, the weather and light data are shown on the chart. (Point.)"

(2) Average sunrise is \_\_\_\_\_, with the average sunset \_\_\_\_\_. Moon rise is \_\_\_\_\_, with \_\_\_\_\_ percent illumination. The average temperature in the daytime is \_\_\_\_\_, with a nighttime average of \_\_\_\_\_."

**f. Enemy situation.**

(1) *General situation.*

"Sir, the major enemy units in and around our area of operations are believed or suspected to be the

\_\_\_\_\_ at \_\_\_\_\_ ;

\_\_\_\_\_ at \_\_\_\_\_ ;

\_\_\_\_\_ at \_\_\_\_\_ ."

(2) *Detailed situation.*

(a) "Sir, the units in our area that we are most concerned with are: \_\_\_\_\_ at \_\_\_\_\_; \_\_\_\_\_ at \_\_\_\_\_; \_\_\_\_\_ at \_\_\_\_\_."

(b) "These units will affect our mission as follows: \_\_\_\_\_."

(3) *Reaction times.*

(a) "Sir, the reaction time for the units in our area are \_\_\_\_\_."

(b) "Sir, the priority intelligence requirements and associated specific information requirements for our mission are shown on this chart."

(c) "Other information requirements and associated SIR for this mission are shown on this chart."

END BRIEF OF OBSERVER: "Sir, I will be followed by (rank, name) senior observer."

3. SENIOR OBSERVER: "Good (**morning**), sir."a. **Infiltration.**

(1) "Sir, Team \_\_\_\_\_ will infiltrate by means of \_\_\_\_\_, at LZ or DZ, at grid coordinates \_\_\_\_\_ at \_\_\_\_\_. The alternate LZ or DZ is at grid coordinates \_\_\_\_\_ at \_\_\_\_\_."

(2) "The load plan is shown by this chart." (He explains, if necessary.)

(3) "The route for our infiltration is shown on this map (chart) (general flight, truck, or foot routes)."

(4) "Checkpoints along the infiltration route are (location pinpointed on map and description of each)—

1. \_\_\_\_\_; 2. \_\_\_\_\_; 3. \_\_\_\_\_; 4. \_\_\_\_\_."

(5) "The point of no return is \_\_\_\_\_."

(6) "The assembly plan in case of downed aircraft (wrecked truck) is as shown by this chart." (He explains, if necessary.)

(7) "The assembly plans for the primary and alternate LZs or DZs are as shown on these charts." (Primary and alternate rally point for each LZ or DZ.)

Primary \_\_\_\_\_, Alternate \_\_\_\_\_, Primary \_\_\_\_\_, Alternate \_\_\_\_\_."

(8) "Sir, our actions on enemy contact during infiltration are as shown on these charts." (He explains, if necessary.)

(9) "Diagram of LZs or DZs shows what actions to perform or the direction to move for enemy contact."

**b. Foot Movement.**

(1) "Sir, the primary route for foot movement is shown on the overlay."

(a) "Leg 1 is \_\_\_\_\_ degrees magnetic for \_\_\_\_\_ meters, to \_\_\_\_\_ (obstacles, contour, terrain feature)."

(b) "Leg 2 is \_\_\_\_\_ degrees magnetic for \_\_\_\_\_ meters, to \_\_\_\_\_ (terrain features)."

(c) "Leg 3 is \_\_\_\_\_ degrees magnetic for \_\_\_\_\_ meters, to \_\_\_\_\_ (terrain features)."

(d) "Leg 4 is \_\_\_\_\_ degrees magnetic for \_\_\_\_\_ meters, to \_\_\_\_\_ (terrain features)."

(2) "Sir, the alternate route for foot movement is shown on the overlay."

(a) "Leg 1 is \_\_\_\_\_ degrees magnetic for \_\_\_\_\_ meters, to \_\_\_\_\_ (obstacles, contour, terrain feature)."

(b) "Leg 2 is \_\_\_\_\_ degrees magnetic for \_\_\_\_\_ meters, to \_\_\_\_\_ (terrain features)."

(c) "Leg 3 is \_\_\_\_\_ degrees magnetic for \_\_\_\_\_ meters, to \_\_\_\_\_ (terrain features)."

(d) "Leg 4 is \_\_\_\_\_ degrees magnetic for \_\_\_\_\_ meters, to \_\_\_\_\_ (terrain features)."

(3) "Sir, the route is boxed by \_\_\_\_\_ (terrain features)."

(4) "Significant obstacles and danger areas along the route are \_\_\_\_\_."

(5) "Our planned rally points are \_\_\_\_\_." (He points out on the map.)

(6) "Action at the rally points are \_\_\_\_\_ (in accordance with the team SOP)."

(7) "Sir, the movement formations that will be used by the team are shown on these charts." (He explains, as necessary.)

**c. Actions on Contact.**

(1) "Sir, actions on enemy contact are as shown on these charts (in accordance with the team SOP)."

(2) "Sir, actions at danger areas are as shown on these charts (in accordance with the team SOP)."

(3) "Sir, **this chart shows our** actions at short halts, long halts, overnight rest positions, patrol bases, communications sites, en route radio transmissions, and observation points."

(4) "Sir, actions at the objective are as follows: \_\_\_\_\_." (He uses a sketch or sand table, and explains.)

(5) "Sir, follow-on missions will be received by way of \_\_\_\_\_."

END BRIEF OF SENIOR OBSERVER: "Sir, I will be followed by (rank, name), observer."

5. OBSERVER: "Good (**morning**), sir."

**a. Exfiltration.**

(1) "Sir, Team \_\_\_\_\_ will exfiltrate by way of \_\_\_\_\_, at \_\_\_\_\_, from PZ \_\_\_\_\_ at grid coordinates \_\_\_\_\_. The Alternate PZ is at grid coordinates \_\_\_\_\_."

(2) "The PZ will be secured by \_\_\_\_\_."

(3) "We will set up and mark the PZ using \_\_\_\_\_, with the proper code from the SOI."

(4) "Sir, the load plan for exfiltration is as depicted on the chart (in accordance with the team SOP)." (He explains, if necessary.)

**b. Evasion Plan.**

"Sir, the evasion plan is as shown on the overlay. The following situations and code words will cause us to initiate our evasion plan: \_\_\_\_\_." (Evasion corridor is shown on map.)

c. **Partisan or Friendly Unit Linkup.**

- (1) "Sir, the friendly units (or partisan forces) we expect to link up with are \_\_\_\_\_."
- (2) "The linkup point at (point out on map) is a \_\_\_\_\_."
- (3) "The far-recognition signal is \_\_\_\_\_."
- (4) "The near-recognition signal is \_\_\_\_\_."
- (5) "The challenge is \_\_\_\_\_."
- (6) "Sir, our security plan for the linkup is \_\_\_\_\_."
- (7) "Our contingency plan is \_\_\_\_\_."
- (8) Diagram of action at linkup point.
- (9) Actions on enemy contact.

END BRIEF OF OBSERVER: "Sir, I will be followed by (rank, name), assistant team leader."

6. ASSISTANT TEAM LEADER: "Good (**morning**), sir."

a. Administration.

- (1) "Sir, the personnel status of Team \_\_\_\_\_ is:"
  - (1) (MOS), \_\_\_\_\_ (Rank) \_\_\_\_\_.
  - (1) (MOS), \_\_\_\_\_ (Rank) \_\_\_\_\_.
  - (1) (MOS), \_\_\_\_\_ (Rank) \_\_\_\_\_.
  - (1) (MOS), \_\_\_\_\_ (Rank) \_\_\_\_\_.
  - (2) (MOS), \_\_\_\_\_ (Rank) \_\_\_\_\_.
- (2) "Sir, enemy prisoners of war will be treated in accordance with the Geneva Convention; civilians will be treated in accordance with the Law of Land Warfare."
- (3) "Team \_\_\_\_\_ received instructions on the Geneva Convention and Law of Land Warfare on \_\_\_\_\_."
- (4) "Sir, friendly soldiers killed in action will be handled \_\_\_\_\_."
- (5) "A preparation for oversea movement was conducted on \_\_\_\_\_. All members of the team needing a **will or power of attorney** have one."

---

(6) "All pay and allowances during the mission are being handled by \_\_\_\_\_."

b. Logistics.

(1) "Sir, the uniform and equipment common to all is shown by this chart."

(2) "The equipment drawn and carried by Team \_\_\_\_\_ is shown by individual breakdown on this chart."

(3) "Equipment shortages encountered are \_\_\_\_\_."

(4) "Projected logistical needs are \_\_\_\_\_."

(5) "Sir, resupply plans, types and contents of aerial bundles, and caches are as follows: \_\_\_\_\_."

(6) "Our destruction plan and priority of destruction are \_\_\_\_\_."

(7) "Sir, all serial numbered items are shown on this chart."

c. Medical.

(1) "Sir, the health status of the personnel on the team is \_\_\_\_\_."

(2) "The team will carry medical supplies listed on this chart for the mission."

(3) "Sir, the expected health hazards in the area of operations include \_\_\_\_\_."

(4) "Sir, each member of the team will carry \_\_\_\_ (type and quantity of rations)."

(5) "Each member will carry \_\_\_\_ quarts of water, and our expected water resupply will be \_\_\_\_\_."

(6) "The team will handle field sanitation by \_\_\_\_\_."

(7) "The team will handle wounded friendly and enemy soldiers by \_\_\_\_\_."

END BRIEF OF ASSISTANT TEAM LEADER: "Sir, I will be followed by (rank, name), radiotelephone operator."

7. RADIOTELEPHONE OPERATOR: "Good (**morning**), sir."

a. "Sir, communications equipment being carried by this team, and who will be carrying it, are shown on this chart."



- b. "Our scheduled receive times along with our high and low frequencies, call signs, and code words are shown on this chart."
- c. "Sir, we have \_\_\_\_ receive times per day."
- d. "Our **no communications plan** is \_\_\_\_\_."
- e. "Sir, our azimuth and distance to the primary base station is \_\_\_\_ for \_\_\_\_ miles, and the alternate base station is \_\_\_\_ for \_\_\_\_ miles."
- f. "The challenge and password is \_\_\_\_\_."
- g. Logs.
  - (1) "The patrol log will be kept \_\_\_\_\_."
  - (2) "The communications log will be at \_\_\_\_\_."
  - (3) "The one-time pads will be at \_\_\_\_\_."
  - (4) "Sir, all arm-and-hand signals are as follows (he shows each one):"

END BRIEF OF RADIOTELEPHONE OPERATOR: "Sir, I will be followed by (rank, name), team leader."

8. TEAM LEADER:

- a. "Sir, the team held the following classes and rehearsals: \_\_\_\_\_." (He shows the chart.)
- b. "The following inspections were held: \_\_\_\_\_."
- c. "Sir, the team will be debriefed immediately on exfiltration."
- d. "Sir, the support areas where we have encountered problems are: \_\_\_\_\_."
- e. "Sir, this concludes the briefback."
- f. "What are your questions?"

END OF BRIEFBACK

**I-2. DEBRIEFING FORMAT**

The following example aids LRS units in debriefing an LRS team during the recovery phase of operations.

**EXAMPLE**

TEAM NUMBER                      DATE/TIME GROUP

MAPS USED:            1:50,000  
                              1:100,000  
                              1:250,000  
                              Special (Photos)

**A. SIZE AND COMPOSITION OF TEAM:**

Team Leader  
Assistant Team Leader  
Radiotelephone Operator  
Senior Observer  
Observer  
Observer  
Attachments  
Detachments

**B. MISSION:****C. TIME OF DEPARTURE (Date/Time Group):**

METHOD OF INFILTRATION:

POINT OF DEPARTURE:

**D. ENEMY SPOTTED EN ROUTE:**

1. Ground activity
2. Air activity
3. Miscellaneous activity

**E. ROUTES OUT (The team provides a detailed description, written and on overlay, of routes from planning area to objective to include):**

1. Planned primary and alternate
2. Actual routes taken and reason for deviation from planned routes.
3. Halts en route, to include objective, LZ, security.
4. Date/time group arrived at objective area.

F. TERRAIN THROUGHOUT THE OBJECTIVE AREA:

1. Roads, trails, and railroad tracks:
  - a. Type (single or multi-lane, hard, gravel or dirt surface).
  - b. Condition (dry, wet, muddy, well used, seldom used).
  - c. Trafficability (what type of vehicle will it support).
  - d. Trails or roads not on the map.
2. All open areas:
  - a. Type (pasture, meadow, cultivated, slash, new tree farm).
  - b. Is it suitable for use as a PZ, LZ, or DZ?
  - c. Will the ground support tracked or wheeled vehicles?
3. Forested areas:
  - a. Type of trees.
  - b. Thickness.
  - c. Undergrowth.
  - d. Effects on maneuverability of vehicles and dismounted soldiers.
  - e. Thickness of overhead cover.
4. Rivers and streams:
  - a. Width.
  - b. Depth.
  - c. Fordability to vehicles and soldiers.
  - d. Bridges (include classification report).
  - e. Trafficability under the bridge for boats or barges.
5. Key terrain.
6. Limiting terrain.
7. Major obstacles to soldiers and vehicles.
8. Availability of cover and concealment.
9. Major avenues of approach, any that a battalion-size element or larger, in attack formation, can maneuver through.
10. Any map corrections not already given.

G. ENEMY FORCES AND INSTALLATIONS (the team uses an attached sheet for sketch maps):

H. MISCELLANEOUS INFORMATION:

1. NBC:

2. Abandoned equipment (type, number, location, and markings):
  - a. Out of fuel.
  - b. Destroyed or damaged.
  - c. Abandoned towns or villages.

**I. RESULTS OF ENCOUNTERS WITH ENEMY FORCE AND LOCAL POPULACE:**

1. All sightings (date/time group, activity, location):
  - a. Did the soldiers appear clean shaven, was their morale good or bad?
  - b. Did the uniforms appear clean? All in same uniform? Type of uniforms.
  - c. Weapons (kind, locked and loaded?).
  - d. Condition of vehicles and equipment.
  - e. Nationality and language.
2. Results of enemy contact (date/time group, location, prisoners of war, personnel killed and missing in action).

**J. CAPTURED ENEMY EQUIPMENT AND MATERIAL:**

- K. ROUTES BACK** (The team provides a detailed description, written and on overlay, of routes from planning area to objective to include):
1. Planned primary and alternate.
  2. Actual routes taken and reason for deviation from planned routes.
  3. Halts in route to include designated areas of recovery, PZ, security.
  4. Date/time group arrived at PZ.

**L. EXFILTRATION:**

1. TIME OF EXFILTRATION (Date/time Group):
2. METHOD OF EXFILTRATION:
3. POINT OF EXFILTRATION:

**M. ENEMY ENCOUNTERED EN ROUTE TO BASE:**

1. GROUND ACTIVITY:
2. AIR ACTIVITY:
3. MISCELLANEOUS ACTIVITY:

**N. TIME OF RETURN (Date/time Group):**

POINT OF RETURN:

- O. CONDITION OF TEAM (including disposition of dead and wounded) (team leader includes an estimate of when team is ready to start a new mission):
- P. ALL MAPS RETURNED OR ANY OTHER IDENTIFIABLE MATERIAL RETURNED WITH TEAM: YES or NO? WHAT IS MISSING? STATE ITEM AND APPROXIMATELY WHERE LOST:
- Q. CONCLUSIONS AND RECOMMENDATIONS:
  - 1. To what extent was the mission accomplished?
  - 2. Recommended changes in tactics or operational procedures.
  - 3. What additional information is needed in the mission brief?
  - 4. Recommended equipment changes.
  - 5. The weather effects on the team's operational capability.
  - 6. What else should another team know before going into this area?
  - 7. Is there anything that has not been covered or something that should be highlighted?

TEAM LEADER (PRINT NAME AND GRADE)

UNIT SIGNATURE

DEBRIEFER (PRINT NAME AND GRADE)

UNIT SIGNATURE

ADDITIONAL REMARKS BY INTERROGATOR OR DEBRIEFER:

ENCLOSURES:

- 1. Patrol Log
- 2. Communications Log
- 3. Surveillance Log
- 4. Photograph Log
- 5. Additional Enclosures

DISTRIBUTION:

Operations, LRSU  
S3, MI Battalion  
G2, Division or Corps

## APPENDIX J

**MOVEMENT TECHNIQUES AND BATTLE DRILLS**

*LRS units use movement techniques and battle drills the same as any other unit in the Army. These techniques vary due to the specific needs of an LRS unit. LRS units rehearse movement techniques and battle drills before every mission. After enemy contact they continue the mission or move out of area of operations (evasion and escape). They use deliberate movement. Leaders do not tire out team members (the units watch for trip wires and booby traps). The units use countertracking measures, and sterilization. They use terrain association whenever the situation permits (avoid using direct azimuth). The units react quickly to enemy situations to ensure they have a good chance of survival.*

**J-1 MOVEMENT TECHNIQUES**

Leaders choose movement formations based on METT-T. All arm-and-hand signals are modified so they are at shoulder level or below. Too much movement over the head may reveal the position. The following are the minimum arm-and-hand signals an LRS team should be proficient in using. (See FM 21-60 for more information.)

- Security halt (extended).
- Short halt.
- Listen.
- Look.
- Enemy.
- Danger area.
- Move out.
- Rally point.
- Hide site.
- File formation.
- Diamond formation.
- Freeze.
- Head count.
- Pace count.
- Increase speed.
- All clear.
- Cease firing.

a. **File.** The distance between team members should be about 5 to 10 feet. This allows each member to help the other team member in front of or behind him from being entangled in the vegetation (Figure J-1).

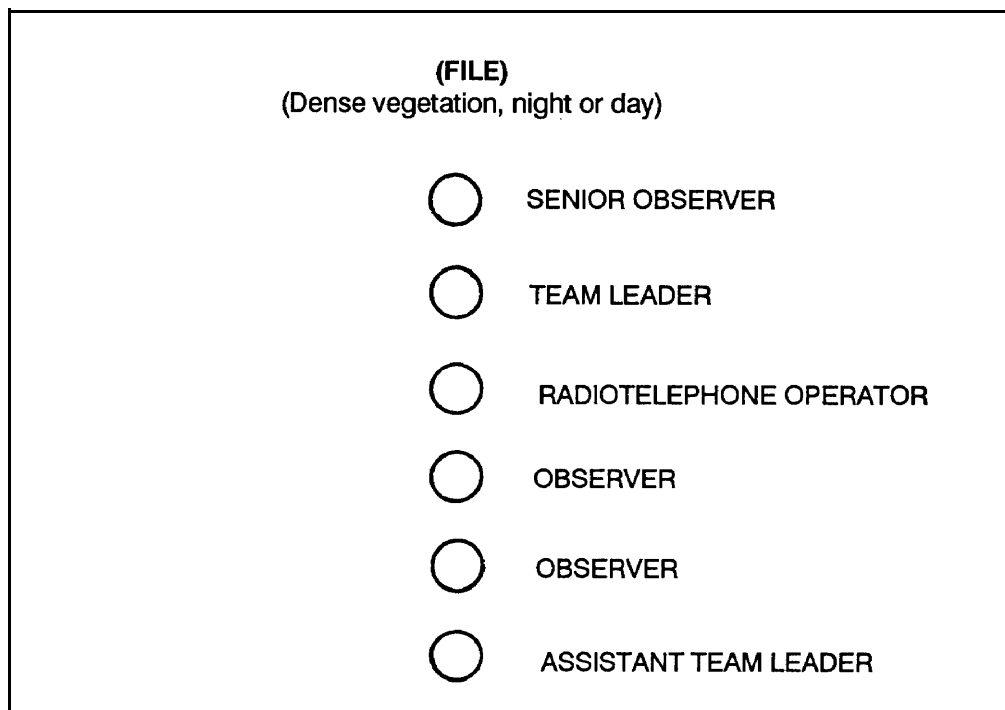
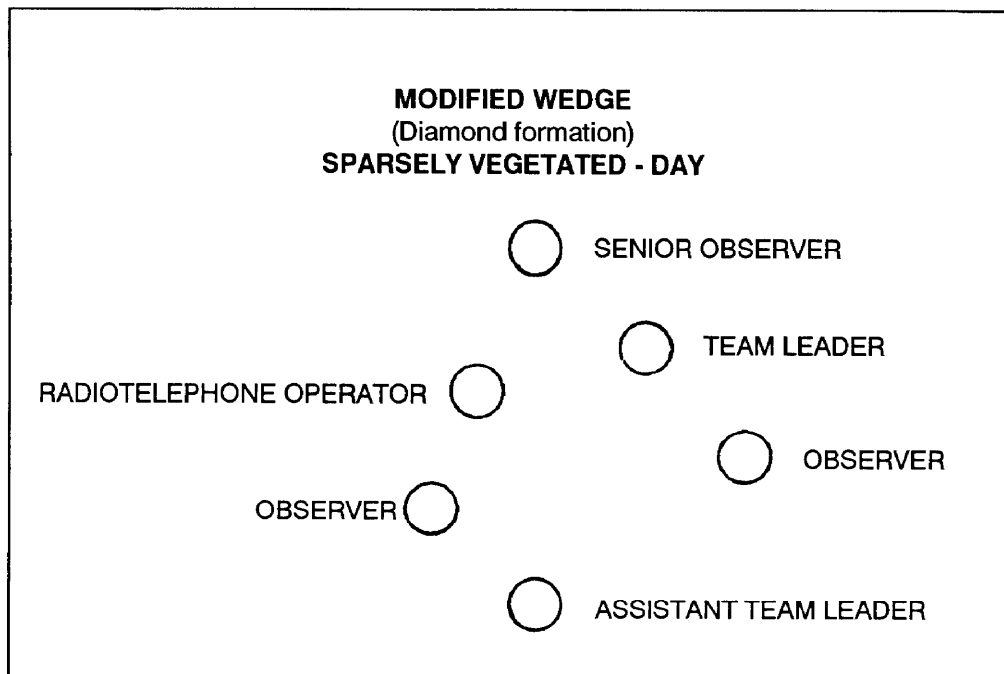

**Figure J-1. File formation.**

(1) Each member can warn the other team members physically or orally of the approaching enemy without a delay or unnecessary noise or movement. If the team members do not take the time to avoid breaking the vegetation, they can be easily tracked. The team moves slowly and easily and takes listening and rest breaks often.

(2) A variation to the file is to have an observer behind the senior observer in heavy vegetation so they can trade off during movement. Also, if the likelihood of enemy contact increases and booby traps are probable, the senior observer can concentrate on finding the booby traps and the observer can assume responsibility of front security. Weapons stay pointed in a natural direction and the selector switch is on the safe position.

(3) An alternate formation is the modified wedge or diamond formation (Figure J-2). This formation is used in sparsely vegetated terrain and generally during daylight hours. Distances between team members is increased as the terrain and vegetation allows. Another example of an alternate modified wedge formation is in Figure J-3.



**Figure J-2. Diamond formation.**

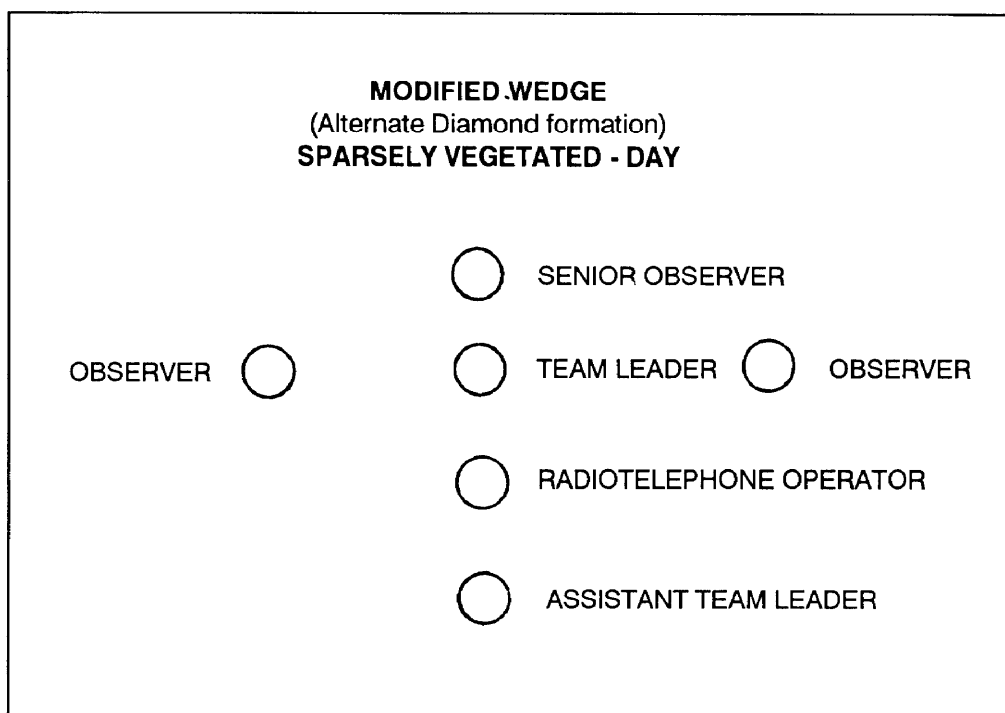

**Figure J-3. Alternate diamond formation.**



b. **Security Halts.** For along halt, team members sit with their feet facing outward and shoulders touching. This aids quick and quiet communication, and guarantees all-round security at all times. This technique offers the smallest signature, and it is the most difficult to detect. (See Figure J-4.) During short halts, team members drop on one knee, face out, and freeze in place. The security halt should not exceed five minutes. If the halt exceeds five minutes, the team should deploy the same as for a long halt. Instead of using trees and limbs, team members should help each other stand up. This reduces the signature. When leaving, the assistant team leader cleans the area and covers the tracks.

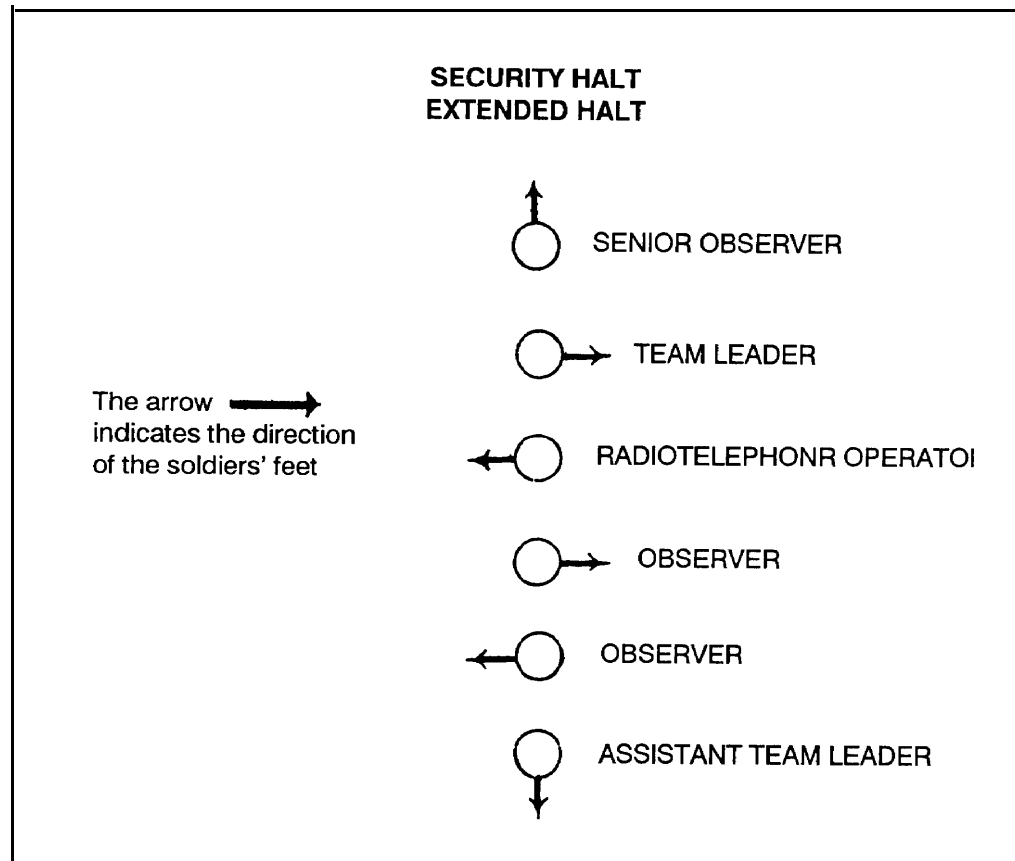

**Figure J-4. Security halt.**

c. **Danger Area.** The lead team member identifies the danger area and moves across, placing his left or right shoulder toward the danger area. The second team member faces the opposite direction as the lead team member. This gives security in both directions. Each member crosses in the

same manner (Figure J-5). As the last member crosses, he should stop and get back-to-back to the next team member to provide security while the assistant team leader sterilizes the crossing area. The team moves across the danger area as fast as possible. The lead team member should select a hill or curve on a trail or road to help conceal the team's movement across the danger area. When planning the route, the leader tries to avoid all danger areas to include likely avenues of approach, roads, rivers, railroads, large open areas, and built-up areas. Some danger areas may not be crossed except during limited visibility.

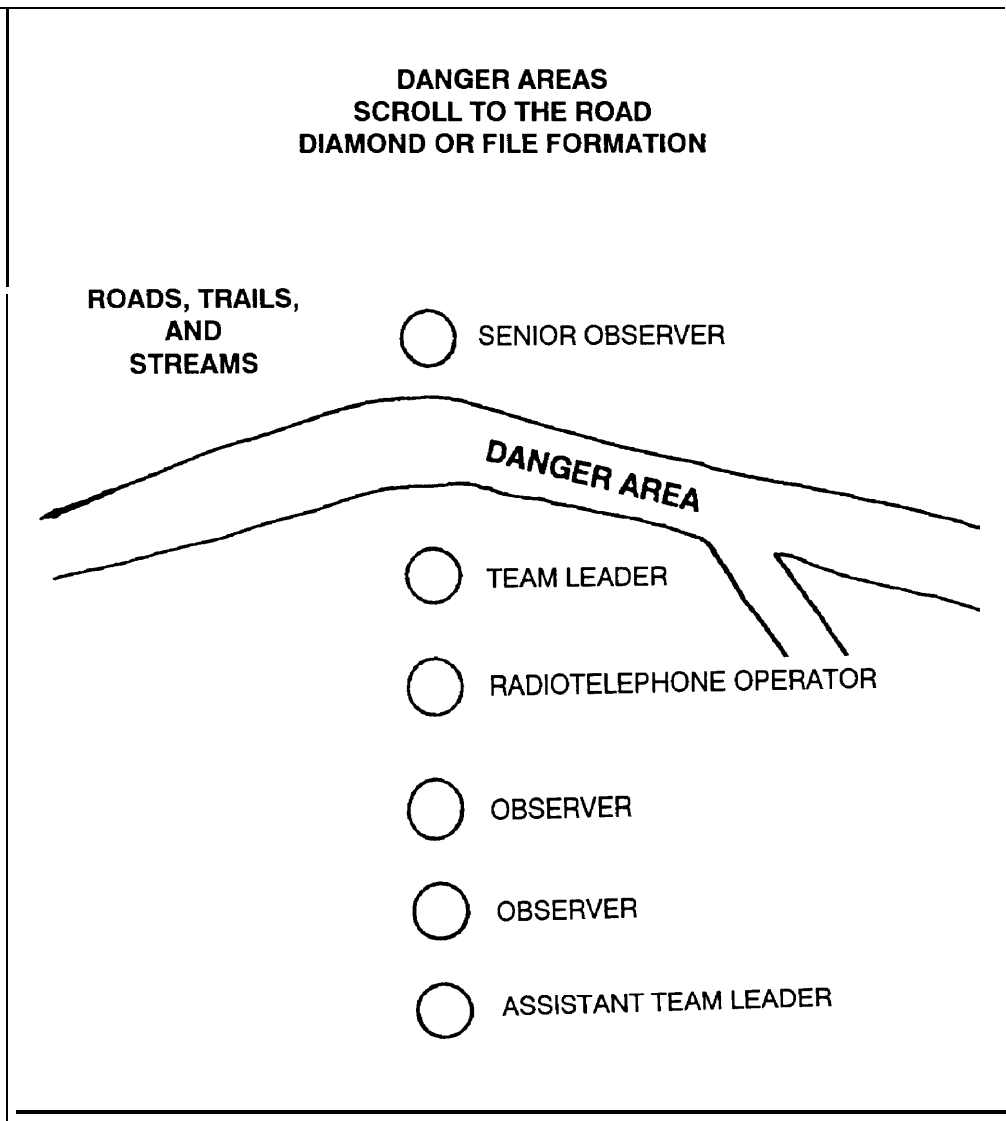
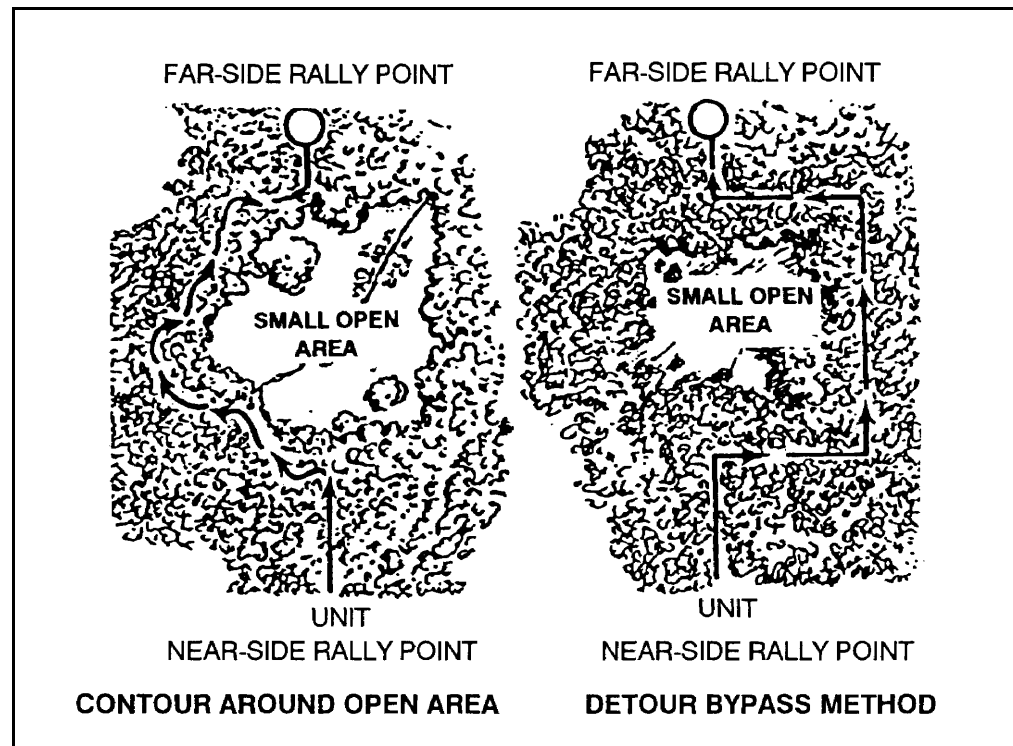

**Figure J-5. Danger Areas.**

(1) When the team crosses a deep gully or ditch, security is established on the near and far side. The team leader ensures that all members are not in the gully or ditch at the same time.

(2) When crossing a stream or river, the team tries to cross at the shallowest point with the most cover and concealment. A reconnaissance should be made first. The crossing is conducted as quickly as possible.

(3) When crossing a small open area, the team uses the contour or detour bypass method. They avoid crossing directly through the open area if possible (Figure J-6.)



**Figure J-6. Crossing a small open area.**

## **J-2. BATTLE DRILLS**

Well-rehearsed battle drills are critical to the success of an LRS team. The team is lightly armed with a limited supply of ammunition and can expect little or no fire support. They can only provide basic life-saving first aid in the event of team casualties. An LRS team should only count on one opportunity to defeat or delay the enemy. As a result, the execution of a battle drill must be well rehearsed to ensure an instantaneous and instinctive response by all team members.

a. **Break Contact.** The team breaks contact as soon as possible, since it lacks assets to stay and fight. METT-T determines which drill is executed. Teams use fire and maneuver in two- or three-man groups. If necessary, the team leader may elect to assault through and consolidate and reorganize, then move to the designated rally point (team SOP), or to an alternate rally point selected by the team leader. The team uses hand grenades, white phosphorus, CS, or smoke to cover the withdrawal. If the team is still in contact, they repeat fire and movement. (Figure J-7, page J-8 and Figure J-8, page J-9.)

(1) The team executes fire and movement by two-or three-man teams until contact with the enemy is broken.

(2) When contacted from the front, the senior observer and another observer return fire with one full magazine each.

(3) An observer and the team leader move to a position to provide support for the withdrawal of the senior observer and observer. Once the senior observer and observer have fired a complete magazine, team leader and observer begin firing, covering the withdrawal of the senior observer and observer to the next firing position.

(4) The two-man team that is bounding back throws CS, white phosphorus, or smoke grenades to cover the withdrawal.

(5) The process of fire and movement continues until contact is broken.

(6) The team members maintain clear fields of fire to the front. Moving teams should not mask the fire of stationary teams.

(7) The RATELO and assistant team leader place a Claymore with a time-delay fuze to slow the enemy. It is placed in the position where the RATELO was when the team began the break contact drill. Once the Claymore is emplaced, the RATELO and assistant team leader help the remainder of the team in breaking contact, or move to a rally point and secure it for the team. When using a Claymore mine in a battle drill, the mine is dual-primed (electrically and time fuze). The mine is always placed facing the direction of team withdrawal.

(8) An alternate method to break contact from the front or rear is the Australian peek. This technique is most effective while the team is in a file formation, the vegetation is dense, or during limited visibility. The second through the sixth team members take one or two steps to the left or right, depending on the terrain. One member at a time passes back through the formation. (Figure J-9, page J-10.)

(9) When contacted from the front, the first member fires a full magazine (automatic or burst). Every other member does the same, one at a time. Each member waits until the member in front of him is even with him or on his left or right before firing a weapon.

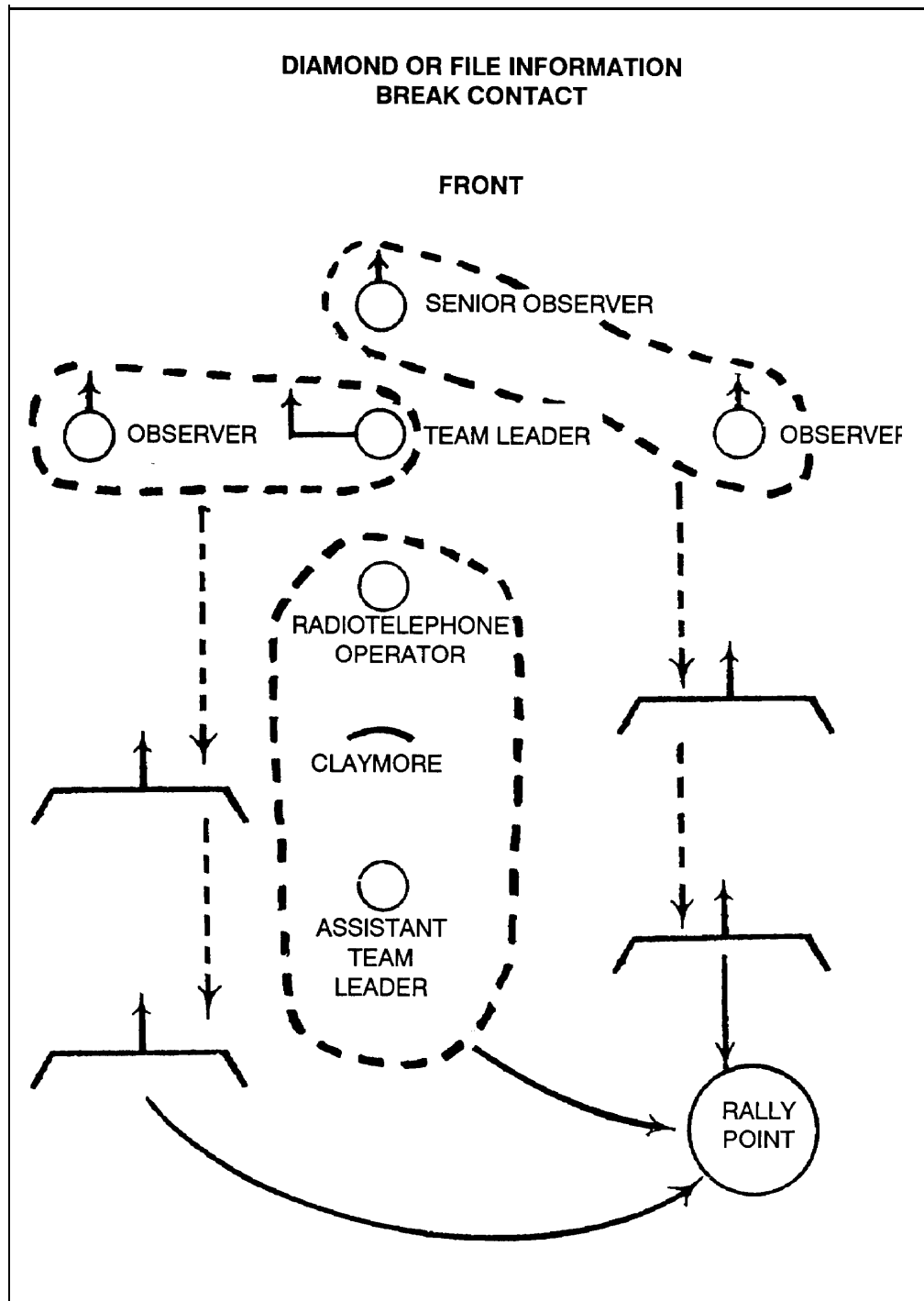
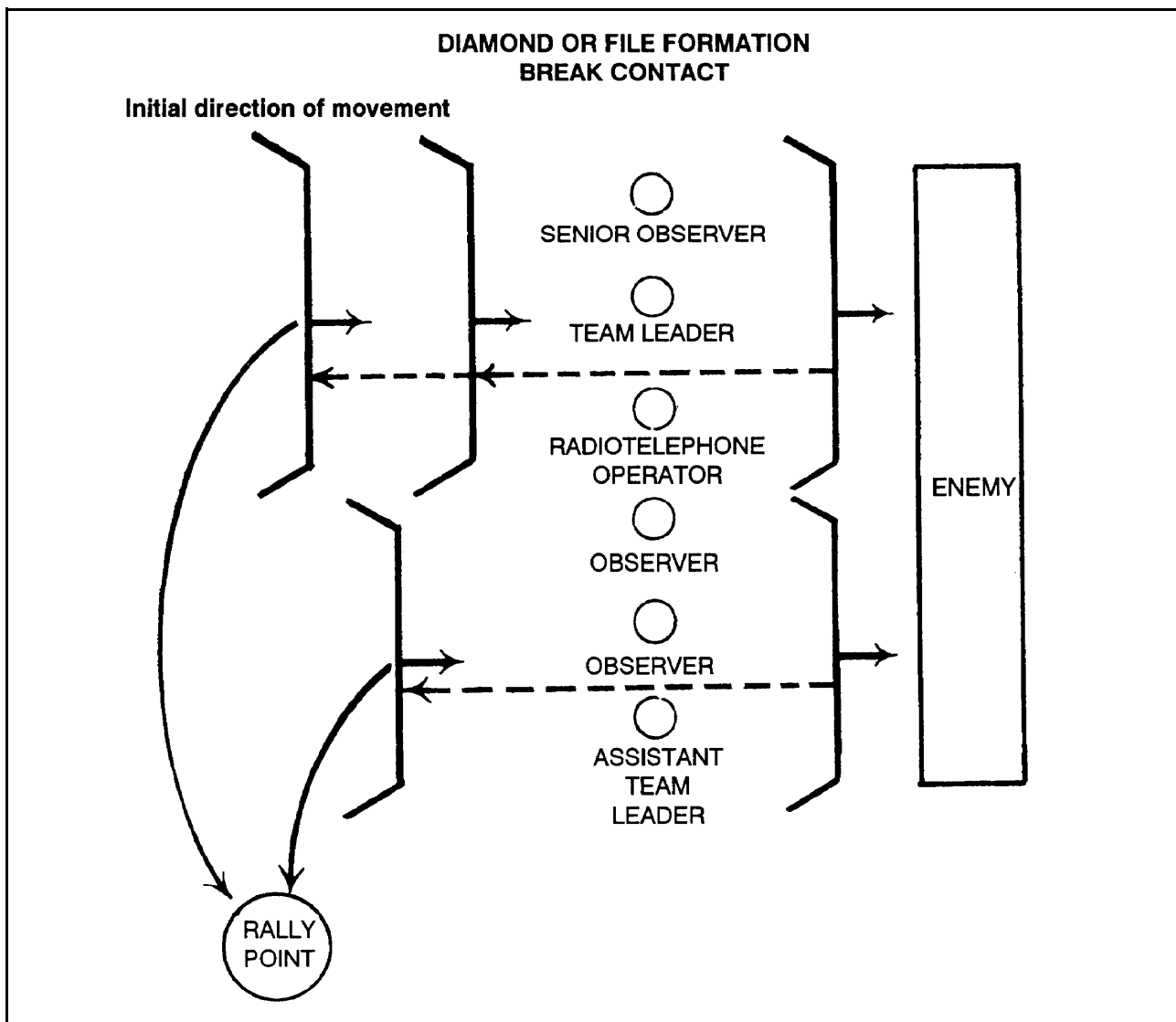

Figure J-7. Break contact, front.



**Figure J-8. Break contact, left or right.**

(10) Individuals move straight back through the inside of the formation, avoiding masking the fires of the members providing covering fire.

(11) The assistant team leader or the last member throws a hand grenade (fragmentary).

(12) As the situation permits, team members can also use CS, white phosphorus, or smoke to cover withdrawal.

(13) During limited visibility, the battle drill may be executed without firing weapons. In this event, the battle drill is still executed in the same sequence.

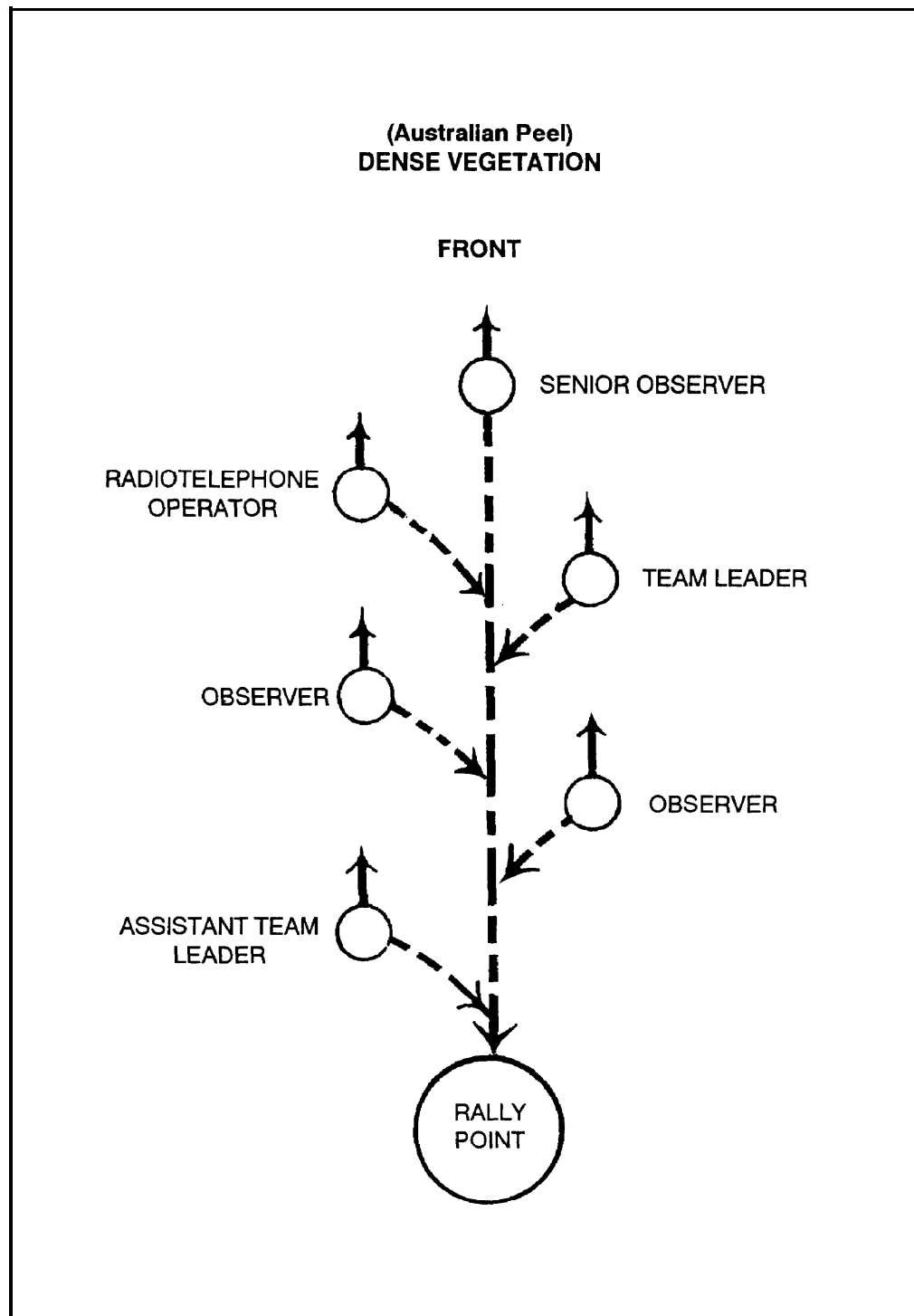

**Figure J-9. Break contact, front (Australian peel).**

(14) Upon completion of the first iteration, the team can emplace a Claymore mine with a time-delay fuze to slow the enemy.

(15) The team initiates fires only if it has been compromised.

(16) If the enemy element breaks contact and ceases fire, the LRS team should cease fire immediately to prevent revealing their new position.

(17) If contact occurs from the rear, the battle drill is executed in the reverse sequence. The first member is the last to throw a hand grenade (fragmentary). Once the battle drill is completed, the team moves to the designated rally point.

b. **React to Air Attack.** The first soldier who hears or sees an aircraft signals "Freeze." The first soldier who sees an attacking aircraft alerts "Aircraft, front (left, right, or rear)." The team moves quickly into a line formation, well spread out, perpendicular to the aircraft's direction of flight (Figure J-10). As each soldier comes on line, he hits the ground, using available cover. Between attacks, the team should seek better cover and concealment. If the team leader wants the team to move out of the area, he gives the clock direction and distance.

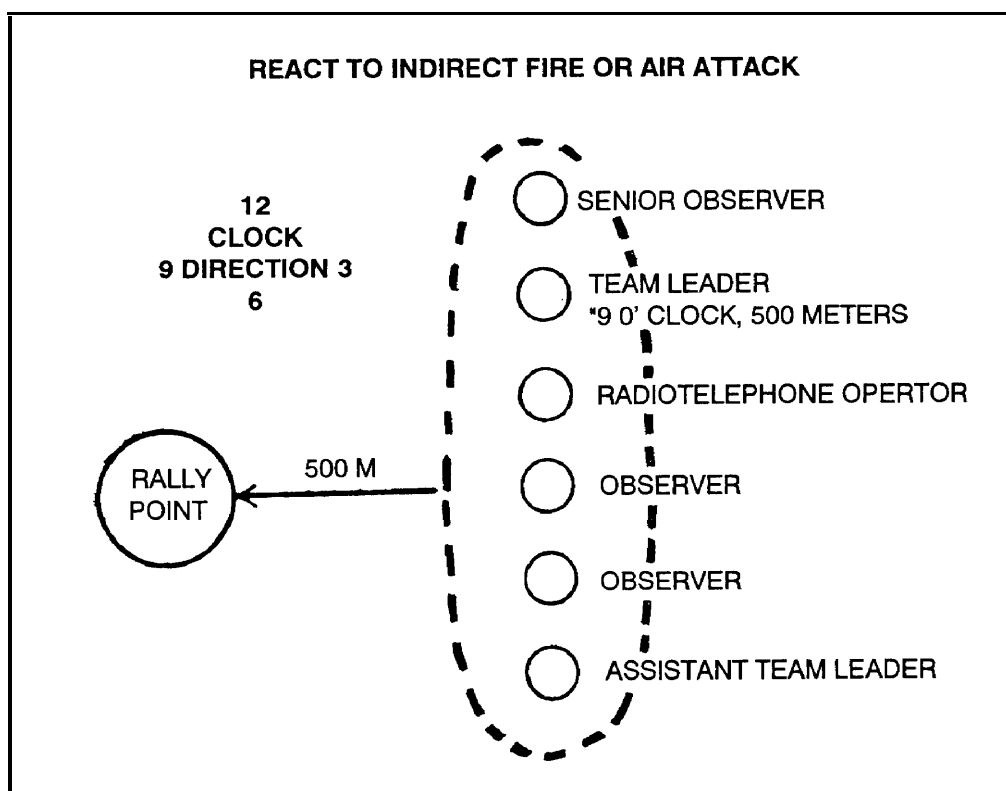

**Figure J-10. React to indirect fire or air attack.**



(1) After the team consolidates and reorganizes, it moves to the last rally point. The team should engage only as a last resort. Massed fires are used to engage attacking aircraft, using the head-on method. Distances for engagement are 50 meters for slow-moving aircraft and 200 meters for fast-moving aircraft. The team leader makes the decision whether to continue the mission or to move out of the area if the team receives fire or returns fire on an aircraft.

(2) An alternate method is for the team to disperse into two 3-man groups or three 2-man groups. On sight of the aircraft, the team leader designates a rally point and gives the command to disperse. On linkup at the rally point, the team leader again assesses the situation and either calls for extraction or continues the mission. (See Figure J-11).

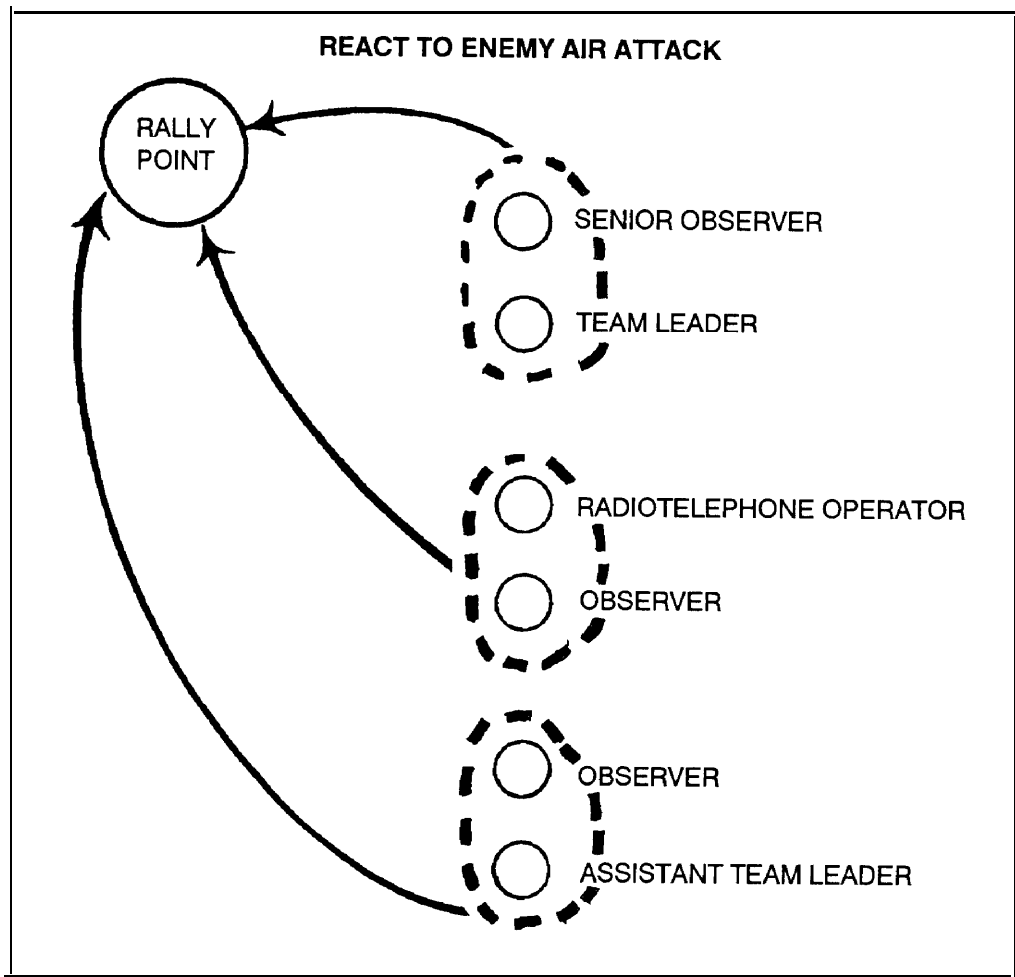

Figure J-11. React to air attack.

c. **React to Indirect Fire.** Upon receiving indirect fire, the team deploys and takes cover. If more rounds impact, the team leader gives the clock position and the direction and distance to move. The team consolidates while moving or at a distance given by team leader. Once the team is consolidated and reorganized, it moves out of the area quickly. The enemy may adjust fires as the team moves. The direction of movement should remain oriented to the 12 o'clock position. The team may elect to move to the last rally point or as otherwise directed by the team leader. The team leader makes a decision to continue the mission or to move out of the area of operations.

d. **React to Flares.** If the team encounters flares, it should execute the following actions:

(1) *Ground flares.* The team moves out of the illuminated area and takes cover. Each soldier closes his firing eye to protect his night vision. The team leader decides the next direction to move.

(2) *Overhead flare with warning.* The team assumes a prone position (behind concealment, when available) before the flare bursts. Each soldier closes his firing eye to protect his night vision.

(3) *Overhead flare without warning.* The team gets into a prone position, making the most use of nearby cover, concealment, and shadows until the flare burns out. Each soldier closes his firing eye to protect his night vision. The team leader gives the direction of movement.

## APPENDIX K

**NIGHT OPERATIONS**

*The ability to fight at night is a necessary skill for infantry forces, and it is a combat multiplier. Infantry forces use night skills to gain a tactical and psychological advantage. Night operations do not depend on technology for success. The absence of night vision devices does not prevent commanders from planning and executing night operations. For LRSU, night operations are normal.*

This appendix is an overview of night fighting techniques. Psychological, physiological, and physical effects of night combat are discussed. Specifics on how to maintain direction, control, and surprise during night operations are also discussed. Although the primary emphasis is on night operations, this information also applies to other limited visibility operations (fog, rain, snow, and sandstorms).

**K-1. NIGHT VISION**

Vision at night is different than during the day. At night, the eye uses spiral eye cells called rods. Rods cannot differentiate color, and are easily blinded when exposed to light. This creates a central blind spot, which causes larger objects to be missed as distances increase.

a. **Protecting Night Vision.** While working and performing tasks in daylight, the exposure to light directly affects night vision. Repeated exposure to bright sunlight has an increasingly adverse effect on dark adaptation. Exposure to intense sunlight for two to five hours causes a definite decrease in visual sensitivity, which can persist for as long as five hours. This effect can be intensified by reflective surfaces such as sand and snow. At the same time, the rate of dark adaptation and the degree of night vision capability will be decreased. Since these effects are cumulative and may persist for several days, military neutral density (N-15) sunglasses or equivalent filter lenses should be used in bright sunlight when night operations are anticipated.

b. **Night Vision Scanning.** Dark adaptation or night vision is only the first step toward maximizing the ability to see at night. Night vision scanning enables soldiers to overcome many of the physiological limitations of their eyes and reduce the visual illusions that so often confuse them. The technique involves scanning from right to left or from left to right using a slow, regular scanning movement (Figure K-1, page K-2). Although both day and night searches use scanning movements, at night soldiers must avoid looking directly at a faintly visible object when trying to confirm its presence.

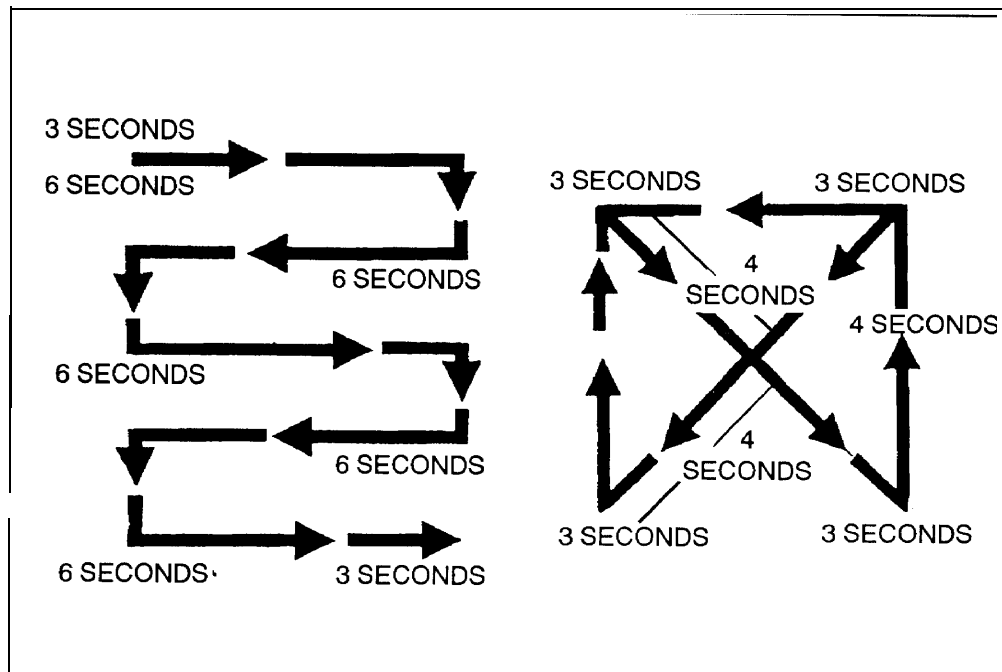

**Figure K-1. Typical scanning patterns.**

c. **Off-Center Vision.** Viewing an object using central vision during daylight poses no limitation, but this technique is ineffective at night. This is due to the night blind spot that exists during low illumination. To compensate for this limitation, soldiers use off-center vision. This technique requires looking 10 degrees above, below, or to either side of an object rather than directly at it (Figure K-2). This allows the peripheral vision to remain in contact with an object.

d. **Dark Adaptation.** Dark adaptation is the process by which the eyes increase their sensitivity to low levels of light. Soldiers adapt to the darkness at varying degrees and rates. During the first 30 minutes in a dark environment, the eye sensitivity increases roughly 10,000 times, but not much further after that time.

(1) Dark adaptation is affected by exposure to bright lights such as matches, flashlights, flares, and vehicle headlights. Full recovery from this exposure may take up to 45 minutes.

(2) Night vision goggles impede dark adaptation. However, if a soldier adapts to the dark before donning the goggles, he gains full dark adaptation in about two minutes after removing them.

(3) Color perception decreases during night operations. Light and dark colors may be distinguished depending on the intensity of the reflected light.

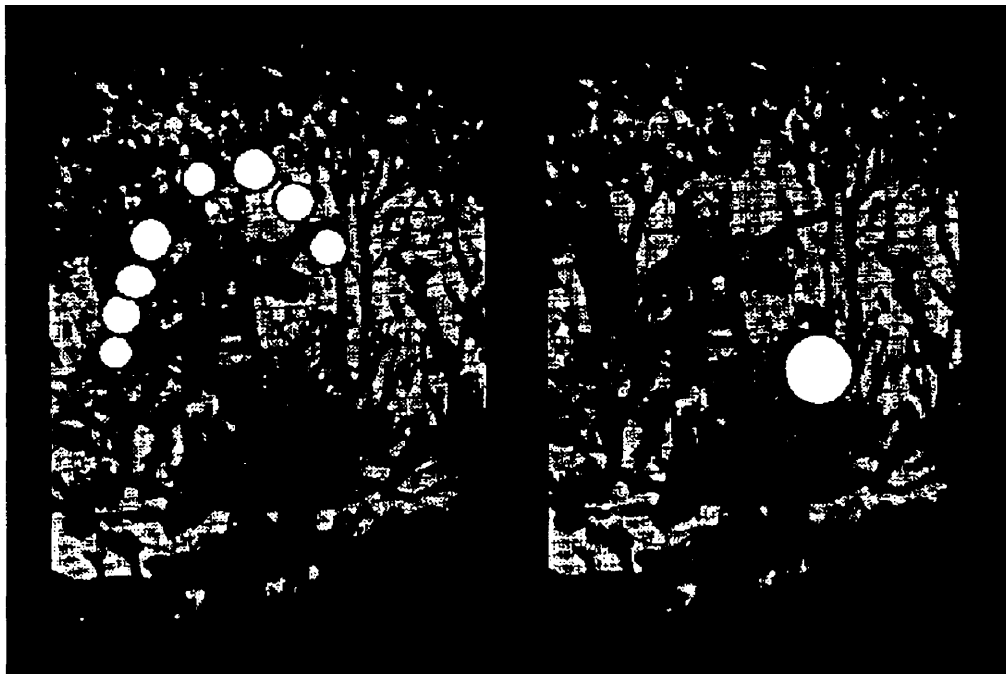

**Figure K-2. Off center viewing technique.**

(4) Visual activity is also reduced. Since visual sharpness during night operations is one-seventh of what it is during the day, soldiers can only see large, bulky objects.

e. **Bleach-Out Effect.** Even when off-center viewing is practiced, the image of an object viewed longer than two to three seconds tends to bleach out and become one solid tone. As a result, the object is no longer visible and can produce a potentially unsafe operating condition. To overcome this condition, the soldier must be aware of this phenomenon and avoid looking at an object longer than two to three seconds. By shifting his eyes from one off-center point to another, he can continue to pick up the object in his peripheral field of vision.

f. **Shape or Silhouette.** Objects must be identified by their shape or silhouette. Familiarity with the architectural design of structures common to the area of operations determines one's success using this technique. For example, the silhouette of a building with a high roof and a steeple can be recognized in the United States as a church, while churches in other parts of the world may have entirely different architecture.

g. **Light Sources and Distances.** Table K-1, page K-4, shows the distances that light sources can be seen at night with the naked eye.

SOURCES	DISTANCES
Vehicle headlights	4 to 8 kilometers
Muzzle flashes from single cannons	4 to 5 kilometers
Muzzle flashes from small-arms weapons	1.5 to 2 kilometers
Bonfire	6 to 8 kilometers
Flashlight	Up to 2 kilometers
Lighted match	Up to 1.5 kilometers
Lighted cigarette	0.5 to 0.8 kilometers

**Table K-1. Light sources and distances.**

NOTE: For observation from the air, these distances can increase two to three times.

**K-2. HEARING**

A soldier’s hearing becomes more acute at night. Several factors contribute to this: increased concentration; sound travels farther in colder, moister air; and less background noise. Practice and training help overcome a soldier’s fear in what he hears at night. Training enables him to discriminate multiple sounds, faint sounds, and sound source directions. Table K-2 shows the distances that sounds can be heard at night.

SOURCES	DISTANCES
Cannon shot	Up to 15 kilometers
Single shot from a rifle	2 to 3 kilomeyers
Automatic weapons fire	3 to 4 kilometers
Tank movement On a dirt road On a highway	Up to 1.2 kilometers 3 to 4 kilometers
Motor vehicle movement On a dirt road On a highway	Up to 500 kilometers Up to 1 kilometers

**Table K-2. Sounds and distances.**

SOURCES	DISTANCES
Movement of troops on foot On a dirt road On a highway	UP to 300 meters Up to 600 meters
Small-arms weapons loading	Up to 500 meters
Metal on metal	Up to 300 meters
Conversation of a few men	Up to 300 meters
Steps of a single man	Up to 40 meters
Axe blow, sound of a saw	Up to 500 meters
Blows of shovels and pickaxes	Up to 1,000 meters
Screams	Up to 1,500 meters
Oars on water	Up to 2,000 meters

**Table K-2. Sounds and distances (continued).**

### K-3. SMELL

Smell is the soldier's most unused sense. Only about two percent of its potential is used. The enemy's diet usually varies from that of US soldiers. Different diets produce different characteristic human odors. People who eat a meat diet have a different body odor than people who eat a vegetarian diet. Once a soldier is accustomed to the enemy's characteristic odor, the odor is easy to detect and differentiate at night. Practice improves skill and confidence. Sensing odors at night can be improved by facing into the wind at a 45-degree angle. The soldier should relax, breathe normally, take sharp sniffs, think about specific odors, and concentrate. Table K-3 shows the distance at which odors can be sensed.

SOURCES	DISTANCES
Diesel fuel	Up to 500 meters
Cigarette smoke	Up to 150 meters
Heat tab	Up to 300 meters

**Table K-3. Odor sources and distances.**

#### **K-4. FATIGUE**

Fatigue is the result of too much work with too little sleep. It has a negative impact on a unit's capabilities in a high stress situation. Fatigue can be avoided in most cases. A work-rest schedule ensures recovery time so that a unit's effectiveness is maintained. The following are some techniques leaders can use to minimize fatigue.

a. A four-hour-on, four-hour-off schedule works well. Two hours on and four hours off works well in bad weather. Other schedules may be just as good. No one schedule suits all soldiers, but a specific schedule might work best for most of the soldiers in a certain team. The leader tries different schedules to find which one works best.

b. Leaders must be sure soldiers sleep or rest during part of each off-shift period.

c. Cross-trained soldiers can rotate through various duties to reduce errors.

d. Leaders should have two soldiers for each job requiring discrimination factors, such as OP procedures or writing and encrypting messages.

e. Order of priority of sleep should be decided in terms of seriousness of errors, complexity of tasks, and tedium of duties. For example, team leaders and RATELOs might be rated priority 1-2 in this system. So, if someone has to miss sleep to check the OP, the team leader may make one check, his assistant two checks, and an observer three checks. The team leader gets the most sleep, since he makes the most serious decisions and processes the most complex information.

f. Some soldiers are more efficient early in their awake cycle; others later on. Leaders try to capitalize on the decision makers' best times for their critical task (this should be planned).

#### **CAUTION**

**ALTHOUGH NIGHT VISION DEVICES CAN INCREASE NIGHT VISION, THEY ALSO DEGRADE THE OTHER SENSES, BECAUSE OF THE CONCENTRATION REQUIRED TO USE THE DEVICE. LEADERS SHOULD PREPARE FOR NIGHT OPERATIONS BY MAKING THE MOST OF ALL THE SENSES. ON CERTAIN OPERATIONS, THIS MAY REQUIRE THAT SOME SOLDIERS NOT USE NIGHT VISION DEVICES.**

#### **K-5. ROUTE SELECTION**

The leader determines the route used for night movement based on METT-T. Since more than one route may satisfy the requirements for METT-T, leaders select the one that offers ease of navigation. Night travel is strenuous, often done when soldiers are tired. This adds to physical and



psychological stress. Ease of navigation contributes both to maintaining direction and control.

a. The selected route is further analyzed using the factors of observation and fields of fire, avenues of approach, key terrain, obstacles, and cover and concealment (OAKOC). METT-T may make one of these factors more critical, such as terrain, cover, or avenues of approach.

b. In analyzing the route, the leader divides it into segments or legs. Establishing legs helps to maintain control. Each leg begins and ends with a change in direction or a prominent terrain feature. The location where the leg begins is a checkpoint. Checkpoints provide a sequential series of points to use for orientation and control. As before, each leg is analyzed using OAKOC. OAKOC helps determine probable hasty ambush sites, likely areas the enemy may use for movement, and where observation may improve.

c. An additional consideration is given to identifying features on the far side of each checkpoint. This feature acts as a catchpoint in case the checkpoint is missed. The catchpoint provides a quick and easy way to reorient movement. Linear features (such as a river, road, or ridge) are the best features to use as catchpoints.

d. The leader makes every effort to conduct a reconnaissance of the route before moving the unit. (The ideal is both a day and night reconnaissance.) As the reconnaissance is conducted, aids for orientation are confirmed, adjusted, or added. Terrain features (hills, cliffs, rivers, ridges, draws) and man-made features (towers, buildings, bridges, and roads) are all aids to navigation. Other options for the leader are ground surveillance radar, wire, illumination rounds, night vision devices, and machine gun tracer fire. When using mortar illumination rounds or tracer fire as position locators, the fire patterns are planned so they can be seen.

e. A final ingredient is the reorientation plan. Reorientation is planned throughout the movement; checkpoints, catchpoints, and position locators are aids. Nevertheless, units do get lost. Therefore, leaders must plan on how to recover, reorient, and complete the mission. They plan for this contingency during the reconnaissance. Leaders should add extra checkpoints if necessary. They use distant terrain features for resection. Leaders plan to resection off indirect fire on known locations. By planning on how to react if the unit becomes lost, the effects of becoming lost are diminished.

## **K-6. NIGHT WALKING**

Leaders must train their units to move silently. Night movement requires the use of different muscles than day movement. Therefore, soldiers must practice moving at night.

a. Walking at night places more strain and exertion on the muscles of the thighs and buttocks as opposed to the calf muscles used for daylight travel. Night movement requires that these muscles become accustomed to taking short careful steps. The object is to make cross-terrain travel as natural as walking along a sidewalk.

b. Night walking proficiency is gained through practice. A soldier begins by looking ahead, then slowly lifts his right foot about knee high. Balancing on his left foot, he eases his right foot forward to feel for twigs and trip wires. He keeps his toes pointed downward. His foot should touch the ground about 6 inches to the front. As his toes come to rest, the soldier feels for the ground with the outside of the toes of his boot. Then, he settles his foot on the ground. As this step is taken, he uses his boot to feel for twigs and loose rocks. Confident of solid, quiet footing, the soldier slowly moves his weight forward, hesitates, then begins lifting his left foot. The process is repeated with his left foot. This method of balanced, smooth walking at night reduces chances of tripping over roots and rocks and reduces noise. Soldiers conditioned to move at night, using the larger muscle groups of their legs, can travel farther with less fatigue.

c. Crossing fords and streams requires extensive team-level training. While crossing these obstacles, security must be established. To cross the ford, the soldier slips silently into the water, maintains footing, and stays alert. He begins crossing by sliding his lead foot forward and dragging his rear foot as if shuffling forward. This maintains balance and prevents being knocked over by the current. When all personnel are across, the leader takes a head count, and the team moves out.

## **K-7. SIGNALS**

Communication at night calls for the leader to use different methods than during daylight. For instance, arm-and-hand signals used during the day may not be visible during darkness. Signals are used to pass information, identify locations, control formations, or initiate activity. The key to tactical communications is simplicity, understanding, and practice. Signals should be as simple as possible to avoid confusion. Leaders should also ensure that soldiers understand and practice each basic signal and its alternate (if necessary).

a. The most common signals relate to the senses: hearing, feeling, and seeing. Audio signals include radio, wire, telephones, messengers, and

grating or clicking of objects together. Messengers should carry written messages to avoid confusion and misinterpretation. When this is not possible, leaders ensure the messenger understands the message by having him repeat it word for word.

b. Oral communication at night should be whispered. To do this, the soldier takes a normal breath, exhales half of it, and then whispers into the other person's ear using the remainder of his breath.

c. When using the radio and telephone at night, operators take precautions. They lower the volume as low as practical. They use headphones or earphones to reduce unnecessary noise. They know the possibility of loud static. They use signals such as breaking squelch a specified number of times. They know that noise travels farther at night than during the day.

d. Visual signals are alternatives to audio signals. These signals may be active or passive and include a wide range of alternatives. Visual signals must be noticed and recognized.

(1) Some passive signals are—

- Sticks indicating direction.
- Light-color paint.
- Tape.
- Rock formations.
- Markings on the ground.
- Powder.

(2) Active signals include—

- Flares.
- Flashlights.
- Illumination rounds (M203, mortar, artillery).
- Chemical lights.
- Infrared strobe lights.
- Strobe lights.
- PVS-5/7 night vision device (infrared light).
- Burning fuel (saturated sand in a can).
- Luminous tape or compass dial.

(3) These signals can be used to identify a critical trail junction, mark a rally or rendezvous point, mark caches, or report that a danger area is clear. White powder can be used to indicate direction at a confusing trail

intersection. A flashlight with a blue filter (with an X cut out of the filter) can signal all clear to a unit crossing a danger area. The possibilities are endless; but, the leader ensures that each signal used is understood by each soldier in the team.

e. The last type of signal is the sense of feel. Soldiers may use wire, string, or rope to communicate without fear of disclosing their positions. This may be used in the hide or surveillance position. The wire is usually loosely secured to an arm or leg. Using prearranged signals, information is relayed from one person to another. Two pulls on the wire may mean a ground-mounted force approaching, while three pulls may indicate a convoy.

f. Regardless of the type of signal used, it must be simple, easy to understand, and practiced. Signals at night aid in control, enhance security, and support surprise. The leader plans the type of signals based on the unit's activity and desired results. He briefs the soldiers and has them practice the signals.

### **K-8. TARGET DETECTION**

Movement at night and successful target engagement depend on knowing the enemy—how he attacks, defends, and uses terrain. Studying enemy techniques and the pattern he establishes assists in target detection at night. Target detection at night requires patience, attention to detail, and practice. Nature provides an endless array of patterns. Man invariably disturbs them or alters them so they are detectable. Sensing the enemy at night requires leaders and soldiers who are patient, confident, and calm.

a. Patience and confidence are critical for effective target sensing at night. While moving through an area, soldiers must think patterns. They look calmly and methodically through the area; they do not focus on the surface alone, but on patterns, noticing straight lines, strange patterns, and light variations.

b. The team looks for sentries or positions at the entrances to draws, overlooking bridges or obstacles, and on the military crest of prominent terrain (used for maximum observation). They look for supporting positions. Soldiers must keep in mind the range distances for supporting weapons, night vision devices, and line-of-sight observation. They search thoroughly for enemy positions and other indications of enemy activity.

c. Soldiers should use their senses when trying to detect the enemy. Hearing and smelling are particularly important. Other indicators of enemy activity are displacement, weathering, littering, and camouflage.

(1) *Sounds*. A soldier places an ear on the ground or on a stick driven 6 inches into the ground. Since the ground is denser than the air, sounds

travel greater distances, though it is difficult to determine direction. Rain and wind mask sounds. Rain causes soldiers to seek shelter in static positions or, if moving, to put ear flaps down. Both actions degrade their ability to hear someone stalking them.

(2) *Odor*. Odors may indicate enemy activity. Odors float downhill on cool, night air and rise on warm, morning air.

(3) *Displacement*. Soldiers check for stones, leaves, or logs that have been displaced. The undersides of these objects are usually darker in color and damp. Crumbled rocks leave lighter colored faces and chips. At night, a flashlight is needed to detect these indicators, so security must be placed well out. If an infrared source is used, broken and crushed vegetation give off a different signature than growing vegetation.

(4) *Weathering*. This is difficult to determine at night without light and experience. This indicator is the change in a “sign” due to the effects of the weather. Its primary value is to measure the age of a sign (new or old).

(5) *Littering*. This represents previous unit locations and whether the soldiers were distracted or undisciplined. Litter may indicate the enemy unit’s state of supply and morale. Soldiers must watch for booby traps left in the litter.

(6) *Camouflage*. Straight lines are rare in nature. Soldiers watch for them. Soldiers identify contrast in color and tone and unnatural vegetation, such as green leaves among dead branches. An infrared source helps detect cut foliage.

## **K-9. MOVEMENT**

Team leaders determine the best formation and movement techniques based on METT-T. The file is often the best formation for night movement. It makes control easier and provides greater speed when moving in dense terrain. One liability may be the inability to mass fires to the front. However, in most instances, the advantages of the file outweigh the disadvantages. Guidelines that aid in movement control and security include—

- Soldiers must be close enough to touch the soldier in front.
- Soldiers do not move unless told to do so.
- Leaders do the talking.
- Leaders position themselves far enough forward to make timely decisions that eliminate confusion.

---

## GLOSSARY

ALZ	alternate landing zone
AOB	alternate operations base
APZ	alternate pickup zone
ARTEP	Army Training and Evaluation Program
attn	attention
C2	command and control
cdr	commander
CM&D	collection management and dissemination
COB	company operations base
COMINT	communications intelligence
commo	communications
COMSEC	communications security
CP	command post
CS	combat support; a chemical agent
CSS	combat service support
DA	Department of the Army
DAR	designated area of recovery
DC	direct current
DD	Department of Defense
DMDG	digital message device group
DOB	detachment operations base
DSVT	digital secure voice terminal
DZ	drop zone
fax	facsimile
FEBA	forward edge of the battle area
FLOT	forward line of own troops
FM	field manual; frequency modulation
FRAGO	fragmentary order
FRIES	fast-rope infiltration/exfiltration system

G1	Assistant Chief of Staff (Personnel)
G2	Assistant Chief of Staff (Intelligence)
G3	Assistant Chief of Staff (Operations and Plans)
HF	high frequency
hq	headquarters
hr	hour
intel	intelligence
IPB	intelligence preparation of the battlefield
IR	information requirements Those items of information regarding the enemy and his environment that need to be collected and processed to meet the intelligence requirements of a commander.
JCS	Joint Chiefs of Staff
km	kilometers
LRS	long-range surveillance
LRSC	long-range surveillance company
LRSD	long-range surveillance detachment
LRSU	long-range surveillance unit
LZ	landing zone
m	meter
METT-T	mission, enemy, terrain, troops and time available
MHz	megahertz
MI	military intelligence
mm	millimeter
MTP	mission training plan
NBC	nuclear, biological, and chemical
NCO	noncommissioned officer

---

NCS	net control stations
NVIS	near-vertical incidence sky wave
OAKOC	observation and fields of fire, avenues of approach, key terrain, obstacles, and cover and concealment
obj	objective
opns	operations
OP	observation post
OPORD	operation order
OPSEC	operations security
ORP	objective rally point
PIR	priority intelligence requirements Those intelligence requirements for which a commander has an anticipated and stated priority in his task of planning and decision making.
plt	platoon
PVC	polyvinyl chloride (pipe)
PZ	pickup zone
R&S	reconnaissance and surveillance
RATELO	radiotelephone operator
RDF	range direction finder
RP	release point
S2	intelligence officer
S3	Operations and Training Officer
SALUTE	size, activity, location, unit, time, and equipment
SATCOM	satellite communication(s)
SB	switchboard
SEAD	suppression of enemy air defenses
SIR	specific information requirements Those basic questions that need answering to confirm or deny the existence of an indicator.



SOI	signal operation instructions
SOP	standing operating procedure
SPIES	special patrol infiltration/exfiltration system
surv	surveillance
SURVIVAL	size up the situation; undue haste makes waste; remember where you are; vanquish fear and panic; improvise; value living; act like the natives; live by your wits (but for now learn the basis)
TC	training circular
tm	team
TOC	tactical operations center
UHF	ultra high frequency
US	United States
USAF	United States Air Force
USMC	United States Marine Corps
USN	United States Navy
UTM	universal transverse mercator (grid)
VHF	very high frequency
VIP	very important person

---

## REFERENCES

### Sources Used

These are the sources quoted or paraphrased in this publication.

### Documents Needed

These documents must be available to the intended users of this publication.

AR 350-41.	Training in Units. 19 March 1993.
AR 385-62.	Regulations for Firing Guided Missiles and Heavy Rockets for Training, Target Practice and Combat. 5 January 1977.
AR 385-63.	Policies and Procedures for Firing Ammunition for Training, Target Practice and Combat. 15 October 1983.
ARTEP 7-8-MTP.	Mission Training Plan for the Infantry Rifle Platoon and Squad. 30 September 1988.
ARTEP 7-93-MTP.	Mission Training Plan for the Long-Range Surveillance Company/Detachment Team (Hvy/Lt). 27 December 1988.
DA Form 1155.	Witness Statement on Individual. June 1966.
DA Form 1156.	Casualty Feeder Report. June 1966.
DA Form 1306.	Statement of Jump and Loading Manifest. May 1963.
DA Form 1594.	Daily Staff Journal or Duty Officer's Log. November 1962.
DA Form 2404.	Equipment Inspection and Maintenance Worksheet. April 1979.
DA Pamphlet 350-38.	Standards in Weapons Training. 15 February 1993.
DD Form 1380.	US Field Medical Card. June 1962.
DD Form 1833.	Isolated Personnel Report (LRA). February 1984.
FM 1-402.	Aviator's Recognition Manual. 6 August 1984.
FM 3-3.	Chemical and Biological Contamination Avoidance. 16 November 1992.
FM 3-4.	NBC Protection. 29 May 1992.

- \*FM 3-5. NBC Decontamination. 23 July 1992.
- FM 3-50. Smoke Operations. 4 December 1990.
- \*FM 3-100. NBC Defense Chemical Warfare, Smoke, and Flame Operations. 23 May 1991.
- FM 5-33. Terrain Analysis. 11 July 1990.
- \*FM 5-36. Route Reconnaissance and Classification. 10 May 1985.
- \*FM 7-8. Infantry Rifle Platoon and Squad. 22 April 1992.
- FM 11-64. Communications-Electronics Fundamentals: Transmission Lines, Wave Propagation and Antennas. 13 June 1985.
- FM 11-65. High Frequency Radio Communications. 31 October 1978.
- FM 12-6. Personnel Doctrine. 23 August 1989.
- FM 21-10. Field Hygiene and Sanitation. 22 November 1988.
- FM 21-26. Map Reading and Land Navigation. 7 May 1993.
- FM 21-60. Visual Signals. 30 September 1987.
- FM 21-75. Combat Skills of the Soldier. 3 August 1984.
- FM 21-76. Survival. 5 June 1992.
- FM 22-9. Soldier Performance in Continuous Operations. 12 December 1991.
- FM 24-1. Signal Support in the AirLand Battle. 15 October 1990.
- FM 24-18. Tactical Single-Channel Radio Communications Techniques. 30 September 1987.
- \*FM 25-100. Training the Force. 15 November 1988.
- \*FM 25-101. Battle Focused Training. 30 September 1990.
- FM 26-2. Management of Stress in Army Operations. 29 August 1986.

---

\*This source was also used to develop this publication.

- 
- FM 31-20-5. Special Reconnaissance Tactics, Techniques, and Procedures for Special Forces. 23 March 1993.
- \*FM 31-70. Basic Cold Weather Manual. 12 April 1968.
- FM 34-3. Intelligence Analysis. 15 March 1990.
- FM 34-7. Intelligence and Electronic Warfare Support to Low-Intensity Conflict Operations. 18 May 1993.
- FM 34-8. Combat Commander's Handbook on Intelligence. 28 September 1992.
- FM 34-10. Division Intelligence and Electronics Warfare Operations. 25 November 1986.
- FM 34-130. Intelligence Preparation of the Battlefield. 8 July 1994.
- FM 90-3. Desert Operations. 24 August 1993.
- FM 90-5 (HTF). Jungle Operations (How to Fight). 16 August 1982.
- FM 90-6. Mountain Operations. 30 June 1980.
- FM 90-18. (CSAR) Multi-Service Procedures for Combat Search and Rescue. 31 May 1991.
- FM 100-2-1. Soviet Army Operations and Tactics. 16 July 1984.
- FM 100-2-2. The Soviet Army: Specialized Warfare and Rear Area Support. 16 July 1984.
- FM 100-2-3. The Soviet Army Troops, Organization, and Equipment. 6 June 1991.
- \*FM 100-5. Operations. 14 June 1993.
- FM 100-20. Military Operations in Low Intensity Conflict. 5 December 1990.
- \*FM 101-5-1. Operational Terms and Symbols. 21 October 1985.
- FM 101-10-1/1. Staff Officers Field Manual-Organization, Technical and Logistical Data (Volume 1). 7 October 1987.

---

\*This source was also used to develop this publication.

Joint Pub 1-02.	Department of Defense Dictionary of Military and Associated Terms. 1 December 1989.
Joint Pub 3-07.2.	Joint Tactics, Techniques, and Procedures for Antiterrorism. 25 June 1993.
STP 21-1-SMCT.	Soldier's Manual of Common Tasks Skill Level 1. 1 October 1990.
STP 21-24-SMCT.	Soldier's Manual of Common Tasks, Skill Levels 2-4. 1 October 1991.
TC 21-24.	Rappelling. 24 September 1991
TC 31-29.	Special Forces Operational Techniques. 9 September 1988.
TM 11-5820-467-15.	Operator's, Organization, Direct Support, General Support, and Depot Maintenance Manual for Antenna Group, An/GRA-50. 19 July 1961.
TM 11-5820-887-10.	Operator's Manual for Digital Message Device Group, OA-8990/P. 20 August 1982.
TM 11-5820-919-12.	Operator's and Organizational Maintenance Manual for Radio Set, AN/PRC-104A. 15 January 1986.
TM 11-5820-923-12.	Operator's and Organization Maintenance Manual for Radio Set, AN/GRC-213. 14 February 1986.
TM 11-5820-924-13.	Operator's, Organizational and Direct Support Maintenance Manual for Radio Set, AN/GRC-193A. 14 February 1986.
TM 11-5820-1025-10.	Operator's Manual for Radio Set AN/PRC-126. 1 February 1988.

**Readings Recommended**

These readings contain supplemental information.

FM 31-20.	Doctrine for Special Forces Operations (U). 20 April 1990.
-----------	--

## INDEX

**A****air assault, 6-28**

- air movement plan, 6-29
- ground tactical plan, 6-29
- landing plan, 6-29
- loading plan, 6-29
- staging plan, 6-20

**air defense artillery support, 4-5****air insertion, 3-8**

- assembly, 3-10
- planning, 3-11
- special airborne assault techniques, 3-10
- special factors, 3-9

**airborne operations, 6-36**

- air movement plan, 6-37
- landing plan, 6-37
- marshalling plan, 6-37

**alternate operations base, 2-7, 2-11, 2-12, 2-19, 2-25, D-1, D-23****amphibious infiltration, 3-11**

- actions at the drop site, 3-12
- actions on the beach, 3-13
- beach landing site, 3-12
- contingency planning, 3-13
- helocasting, 3-13
- insertion by air from ship, 3-13
- navigation, 3-12
- planning, 3-11
- rehearsals, 3-14
- routes, 3-12
- tactical deception, 3-12

**antenna construction, 2-25, D-1, D-7**

- classification, D-8
- expedient wire, D-18
- frequency, D-7

- grounding, D-18
- insulators, D-17
- polarization, D-8
- resonance, D-7
- supports, D-17
- terminating resistors, D-17

**antenna selection, 2-25, D-10**

- half-wave dipole, D-11
- inverted Vee, D-12
- long-wire, D-13
- sloping Vee, D-14

**area reconnaissance, B-1**

- organization, B-1
- techniques, B-2
  - long-range observation, B-2
  - long-range surveillance, B-2
  - short-range observation, B-2
  - short-range surveillance, B-2

**arm-and-hand signals, 3-17****Army aviation support, 4-3, 6-28****Army operations doctrine, 1-3**

- agility, 1-4
- depth, 1-4
- initiative, 1-3
- synchronization, 1-4
- versatility, 1-4

**B****base radio station, 1-7, 2-11, 2-22, 2-23**

- operations, 2-25

**battle drills, J-6**

- break contact, J-7
- react to air attack, J-11
- react to flares, J-13
- react to indirect fire, J-13

briefback, 3-1, 3-3, 3-5, I-1

## C

capabilities, 1-9

cold weather operations, C-5

collateral activities, 2-5

collection management and dissemination (CM&D) section, 2-2, 2-3, 2-6, 2-8, 2-11, 2-19

combat support, 1-4, 2-8, 4-1

air defense, 4-5

army aviation, 4-3

electronic warfare, 4-5

engineer, 4-5

fire, 4-3

joint service, 4-1 (see also joint service support)

combat service support, 1-4, 2-8, 4-5, 5-2

maintenance, 4-8

medical, 4-8

miscellaneous services, 4-9

finance, 4-9

religious, 4-9

rigger, 4-9

resupply, 4-6

sources, 4-6

supply, 4-6

transportation, 4-6

command and control, 1-4, 1-7, 2-1, 6-36

structure, 2-1

communication, 1-2, 1-5, 1-7, 2-11, 2-19, 2-26, 2-27, 2-34, 3-19, 4-2, C-1, C-5, D-1

antenna construction for, D-7 (see also antenna construction)

antenna repair for, D-15

antenna selection for, D-10 (see also antenna selection)

equipment, 1-10, D-19

antenna (AN/GRA-50), D-20

antenna (AS-2259/GR), D-20

base radio (AN/GRC-193), 2-25, D-20

base radio (AN/GRC-213), 2-25, D-20

communication shelter (AN/TSC-128), D-21

digital message device group (OA-8990/P), 2-23, 2-26, D-20

emergency-distress radio (AN/PRC-90, AN/PRC-112), 1-10

encryption message burst device (KL-43C), D-20

high-frequency (HF) radio (AN/PRC-104), 2-35, 4-1, D-20

tactical satellite radio, 2-20, 2-26

very high-frequency (VHF) (FM) radio (AN/PRC-126), 2-35, 4-1, D-20

frequency propagation, D-2

ground-wave, D-2

sky-wave, D-2, D-3

net, 2-20

security, 1-5, 2-7, 2-9, 2-25, 2-26, 5-1, 5-2

site, 1-6, 2-30, D-23

communications platoon, 1-7

base radio stations, 1-7

headquarters section, 1-7

communications section, 1-8

company leadership, 2-5

chemical noncommissioned officer, 2-6, 2-17

communications platoon leader, 2-7

company commander, 2-5

executive officer, 2-6

first sergeant, 2-6

intelligence officer, 2-6, 2-15

liaison noncommissioned officer, 2-6, 2-17

operations officer, 2-6, 2-14, 2-29

platoon sergeant, 2-7, 2-34

- surveillance platoon leader, 2-7, 2-29, 2-34  
team leader, 2-7
- company operations base, 2-6, 2-11, 2-12 (Figure 2-4), 2-19, 2-25, 3-24, D-1, D-23**
- company tactical operations center, 2-14**  
communications, 2-20  
operations, 2-17  
organization of, 2-14  
responsibilities of, 2-14
- contingency plans, 3-1, 3-9, 3-13, 3-22**
- control measures, 3-2**
- coordination, 2-33**
- corps operations base, D-23**
- countertracking, F-1, F-7**
- D**
- damage assessment, 2-2, 2-4, 2-5**
- debriefing, 2-11, 2-18, 3-24, I-9**
- deception, 3-7, 3-12, 4-5, 5-1, 5-2**
- desert operations, C-2**  
individual responsibilities, C-2  
operational considerations, C-3  
hide site, C-4  
insertion, C-4  
movement, C-4  
planning, C-3  
surveillance, C-4
- detachment leadership, 2-7**  
base radio station section chief, 2-9  
detachment commander, 2-8, 2-29, 2-34  
detachment communications sergeant, 2-8  
detachment first sergeant, 2-8  
detachment operations sergeant, 2-8
- executive officer, 2-8  
team leader, 2-9
- detachment operations base, 2-8, 2-11, 2-12 (Figure 2-4), 2-19, 2-25, 3-24, D-1, D-23**
- detachment tactical operations center, 2-17**  
communications, 2-20  
operations, 2-17  
organization of, 2-17  
responsibilities of, 2-17
- displacement, 2-19**
- drop zone, 2-7, 3-2, 3-8, 3-9, 3-10, 4-1**
- E**
- electronic warfare, 2-27**  
electronic counter-countermeasures, 2-7, 2-8, 2-27, 2-30  
preventive, 2-27  
remedial, 2-28  
support, 4-5
- engineer support, 4-5**
- equipment, 1-7, 1-9, 1-10 — 1-11**  
communication, 1-10  
observation, 1-10  
personal clothing, 1-11  
weapons, 1-10
- evasion and escape, 2-32, 2-34, 3-1, 3-22, F-1, F-8**  
long-range, F-8  
short-range, F-8  
planning, F-13  
principles, F-9
- execution phase, 3-16**  
actions in the area of operations, 3-18  
hide site occupation, 3-17  
movement to the area of operations, 3-16  
movement to the extraction site, 3-20



reports, 3-20  
site selection, 3-18  
surveillance site occupation, 3-17

**exfiltration, 1-5, 2-11, 2-30, 2-34, 3-21, 3-23, 4-4, 4-5, 6-1, C-1**  
by air, 1-5, 6-28, 6-36  
by helicopter, 1-5, 6-13  
by land, 3-23  
by water, 1-5, 6-1  
distances, 3-21  
ground, 1-5, 3-21  
landing zone, 6-30  
pickup zone, 6-30  
planning, 6-1  
site, 2-30, 3-21  
terrain, 3-21

**exfiltration phase, 3-21**  
distances, 3-21  
enemy, 3-22  
evasion and escape, 3-22  
extraction by air, 3-23  
land exfiltration, 3-23  
terrain, 3-21

**extraction**  
by air, 3-23, 6-28  
by FRIES, 3-23, 6-24  
by SPIES, 3-23, 6-21  
land, 3-23

**extraction site, 3-20**

## F

**fast-rope infiltration/exfiltration system (FRIES), 3-8, 6-24, C-1**  
consideration for safety, 6-26  
execution of, 6-28  
inspection of, 6-25  
rigging of in a UH-60, 6-25  
rigging of in other aircraft, 6-26

**fire support, 4-3**  
aerial fires, 4-4  
field artillery, 4-3  
naval gunfire, 4-4

**foot movement operations, 6-39**  
movement, 6-39  
planning, 6-39

**FRIES master, 6-27**  
duties, 6-27

## H

**headquarters platoon, 1-7**  
headquarters section, 1-7  
operations section, 1-8

**helicopter operations, 6-13**  
rappelling, 6-13  
special patrol infiltration/exfiltration system (SPIES), 6-14

**helocasting operations, 6-11**

**hide site, 1-5, 2-11, 2-30, 3-17, C-4, E-1**  
actions in, 3-18, E-12  
hasty subsurface, E-3  
leader's reconnaissance of, E-10  
occupation, 3-17, E-10  
selection, 2-30, 3-18, E-10  
sterilization of, E-12  
subsurface, E-7  
surface, E-1  
work priority, E-12

## I

**infiltration, 1-5, 2-11, 2-34, 3-6, 4-1, 4-4, 4-5, 6-1, C1**  
air insertion, 3-8, 3-10, 4-2, 6-13, 6-28, 6-36  
amphibious, 3-11, 4-2, 6-1  
by FRIES, 6-24

by SPIES, 6-14  
 deception, 3-7  
 intelligence, 3-7  
 land, 3-14, 4-2  
 mobility, 3-7  
 planning, 3-11, 6-1  
 reconnaissance, 3-8  
 rehearsals, 3-8  
 sand tables, 3-8  
 security, 3-8  
 site, 2-30, 6-1  
 speed, 3-7  
 staging, 3-6  
 stay-behind, 1-5, 3-6, 6-38  
 stealth, 3-8  
 suppression, 3-8  
 surveillance, 3-8  
 target acquisition, 3-8

**infiltration phase, 3-6**

air insertion, 3-8  
 amphibious infiltration, 3-11  
 land infiltration, 3-14  
 movement to the departure area, 3-6  
 stay-behind, 3-6

**information gathering, 1-1, 1-4, 2-35, 5-1 (see also intelligence collection)**

**information requirements, 2-2, 2-23, 2-31**

**intelligence, 3-7, 5-1, G-1**

collection of, 2-2  
 human, 1-1, 1-3, 2-5  
 preparation of the battlefield, 1-5, G-1  
 resources, G-7  
 training, G-6

**J**

**joint service support, 4-1**

Air Force, 4-1

Marines, 4-2

Navy, 4-2

**jungle operations, C-1**

communication, C-1  
 exfiltration, C-1  
 infiltration, C-1

**L**

**land infiltration, 3-14**

actions at the infiltration site, 3-15  
 actions on enemy contact, 3-14  
 planning, 3-14  
 stay-behind technique, 3-15

**landing zone, 2-7, 2-11, 2-13, 2-34, 3-2, 3-9, 3-11, 3-13, 4-1, 6-13, 6-30**

approach, 6-30  
 departure, 6-30  
 ground slope, 6-30  
 loads, 6-30  
 marking of, 6-31  
 obstacles, 6-30, 6-31  
 operations, 6-35  
 selection of, 6-31  
 surface conditions, 6-30

**limitations, 1-9**

**long-range surveillance company, 1-6, 2-1, 2-3, 2-9**

leadership of, 2-5 (see also company leadership)  
 tactical operations center, 2-14 — 2-17

**long-range surveillance detachment, 1-8, 2-2, 2-3, 2-9**

leadership of, 2-7 (see also detachment leadership)  
 tactical operations center, 2-17 — 2-19

**long-range surveillance platoon, 1-7**

**M**

- messages, 2-18, 2-22, 2-23, 2-25, 2-27**
  - formats, 2-23
- mission folder, 2-31, 2-33, 3-1, 3-2, G-2**
- missions, 1-4, 2-2, 2-3, 2-29, 2-30**
  - characteristics of, 1-4
  - execution of, 1-5
  - planning of, 2-29, 2-30, 2-31, 3-2
  - types of, 2-4
    - collateral activities, 2-5
    - combat search and rescue, 2-4, 2-5
    - damage assessment, 2-2, 2-4, 2-5
    - pathfinder, 2-4, 2-5
    - reconnaissance, 2-5, 4-1
    - surveillance, 1-4, 2-4, 4-1,
    - target acquisition, 2-2, 2-4, 2-5
    - terrain and weather reporting, 2-4, 2-5

**mountain operations, C-5**

**movement, 3-16, 3-20, 6-39, C-4**

- formations, 3-16, J-1
- river, 6-8
- security, 3-17, J-1
- techniques, J-1

**N**

**night operations, K-1**

- fatigue, K-6
- hearing, K-4
- movement, K-11
- night vision, K-1
- route selection, K-6
- signals, K-8
- smell, K-5
- target detection, K-10
- walking, K-8

**no-fire area, 2-11, 2-32, 2-33 (see also restrictive area)**

**O**

**objective, 1-1**

- Army operations doctrine, 1-3
- human intelligence capabilities, 1-1
- information gathering, 1-1
- observation of, 1-10, 2-30, 4-2

**operational security, 1-5, 2-11, 2-20, 2-24, 2-26, 2-31, 2-34, 3-11, 3-25, 5-1, 5-2**

- administrative measures, 2-34
- electronic measures, 2-35
- tactical measures, 2-34

**operations, 1-4, 2-9, 3-1**

- airborne, 6-36 (see also airborne operations)
- characteristics of, 1-4 — 1-5
- cold weather, C-5
- combat search and rescue, 2-4
- combined, 5-2
- control measures of, 3-2
- desert, C-2 (see also desert operations)
- execution phase of, 3-16
- exfiltration phase of, 3-21
- foot movement, 6-39
- helicopter, 6-13
- helocasting, 6-11
- infiltration phase of, 3-6
- jungle, C-1 (see also jungle operations)
- landing zone, 6-35
- mountain, C-5
- night, K-1 (see also night operations)
- other than war, 5-1 (see also operations other than war)
- pathfinder, 2-4
- pickup zone, 6-32
- planning of, 3-1, 3-2
- planning phase of, 3-1, 3-3, 4-6
- recovery phase of, 3-24 (see also recovery phase)

stay-behind, 3-6, 4-5, 6-37 (see also stay-behind operations)  
 vehicle, 6-38 (see also vehicle operations)  
 waterborne, 6-1 (see also waterborne operations)

**operations base, 2-11 (see also specific type)**

**operations other than war, 1-2, 2-3, 5-1**

activities, 5-1  
 missions, 5-3  
 planning for, 5-1  
 rules of engagement, 5-2

**orders, H-1**

fragmentary, 2-3, H-22  
 operation, 2-3, 2-34, 3-1, 3-2, 3-3, 3-4, 3-21, 6-32, H-2, H-3 (Figure H-2)  
 warning, 2-33, 3-1, H-1

**organization, 1-6**

company, 1-6, 2-1  
 detachment, 1-8, 2-2

## P

**personnel recruitment, A-1**

**personnel selection, A-1**

**pickup zone, 2-7, 2-35, 3-11, 3-20, 3-21, 6-30**

approach, 6-30  
 departure, 6-30  
 ground slope, 6-30  
 loads, 6-30  
 marking of, 6-31  
 operations, 6-32  
 selection of, 6-31  
 surface conditions, 6-30

**planning phase, 3-1, 4-6**

contingency plans, 3-1  
 control measures, 3-2

**planning area activities, 3-2**

**priority intelligence requirements, 2-2, 2-23, 2-29, 2-31**

## R

**radio direction finding, 2-35**

**radio intercept, 2-35**

**radiotelephone operator (RATELO), 1-7, 1-8, 2-9, 2-27, 2-28, 3-24, 6-17, D-1**

**reconnaissance, 1-2, 2-2, 2-4, 2-5, 2-30, 3-3, 3-4, 4-1, B-1**

area, 2-5, B-1 (see also area reconnaissance)  
 bridge, B-10  
 route, 2-5, B-6, B-7 (Figure B-5)  
 zone, 2-5, B-3 (see also zone reconnaissance)

**recovery phase, 3-24**

debriefing, 3-24  
 equipment maintenance, 3-24  
 equipment turn-in, 3-24  
 stand-down, 3-24  
 training, 3-25

**rehearsal, 3-1, 3-3, 3-4, 3-8, 3-14**

**reports, 2-22, 2-24, 3-20, B-8 (Figure B-6)**

**restricted areas, 2-11, 2-32, 2-33, 3-2**

**rules of engagement, 5-2**

## S

**scout swimmer, 6-9**

equipment of, 6-9

**security, 1-5, 2-18**

**special patrol infiltration/extraction system (SPIES), 6-14, C-1**

cleaning, 6-21  
 communications, 6-14

- dismounting procedures, 6-15
- emergency procedures, 6-15
- extraction, 6-15
  - organization for, 6-21
- familiarization, 6-14
- land extraction procedures, 6-16
- operational training, 6-16
- repairs, 6-21
- rigging a CH-46 helicopter for, 6-23
- rigging a CH-47 helicopter for, 6-23
- rigging a UH-1H helicopter for, 6-22
- rigging a UH-60 helicopter for, 6-23
- storage, 6-21
- water extraction procedure, 6-17

**special information requirements, 2-2, 2-23, 2-29, 2-31, 3-20, G-2**

**SPIES master, 6-18**

- duties, 6-18 through 6-20
- inspection, 6-20
- qualification, 6-18

**staff journal, 2-18**

**stay-behind operations, 3-6, 4-5, 6-37**

- planning, 6-38
- site preparation, 6-38

**support,**

- aerial fires, 4-4
- air defense artillery, 4-5
- Air Force, 4-1
- Army aviation, 4-3
- combat (see combat support)
- combat service (see combat service support)
- electronic warfare, 4-5
- engineer, 4-5
- field artillery, 4-3
- finance, 4-9
- maintenance, 4-8
- Marine Corps, 4-2

- medical, 4-8
- naval gunfire, 4-4
- Navy, 4-2
- religious, 4-9
- resupply, 4-6
- rigger, 4-9
- supply, 4-6
- transportation, 4-8

**surveillance, 1-2, 1-4, 2-2, 2-4, 4-1, 5-1**

**surveillance detachment, 1-8**

- communications section, 1-8
- headquarters section, 1-8
- surveillance teams, 1-8

**surveillance platoon, 1-7**

- headquarters section, 1-7
- surveillance teams, 1-7

**surveillance site, 1-5, 2-4, 2-11, 2-30, 3-17, C-4, E-1**

- actions in, 3-18, E-12
- occupation, 3-17, E-10
- selection, 2-30, 3-18, E-10

**survival, 1-2, 2-6, F-1, F-16**

## **T**

**tactical operations center, 2-6, 2-11, 2-13, 2-14, 2-17, 2-33, 3-3**

- organization, 2-14 — 2-18
- responsibilities, 2-14 — 2-18

**target acquisition, 2-2, 2-4, 2-5**

**task organization, 2-19**

- brigade task organization, 2-19
- echelons above corps, 2-19

**terrain and weather reporting, 2-4, 2-5**

**tracking, F-1**

- concepts of, F-1
- team organization, F-5
- tracker and dog teams, F-5

**V**

**vehicle operations, 6-38**

- planning, 6-38
- team planning for, 6-38

**W**

**waterborne operations, 6-1**

- helocasting, 6-11
- planning, 6-1

scout swimmer, 6-9

small boat (F470 Zodiac), 6-2

- beaching in surf, 6-4

- launching in surf, 6-3

- maintenance of, 6-8

- offshore navigation, 6-4

- preparation for, 6-3

- river movement, 6-8

- storage of, 6-8

**weapons, 1-10**

**Z**

**zone reconnaissance, B-3**

- converging-routes method, B-4

- fan method, B-4

- successive-sector method, B-5

FM 7-93  
3 OCTOBER 1995

By Order of the Secretary of the Army:

Official:

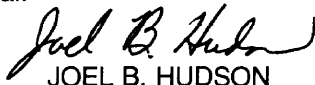

JOEL B. HUDSON

*Acting Administrative Assistant to the  
Secretary of the Army*

00651

DENNIS J. REIMER  
*General, United States Army  
Chief of Staff*

**DISTRIBUTION:**

**Active Army, USAR, and ARNG: To be distributed in accordance with DA Form 12-11E, requirements for FM 7-93, *Long-Range Surveillance Unit Operations* (Qty rqr block no. 0804)**